

Adjustable Louvre Sliding Door





BOX 1/2		
NO.	Section	QTY(pcs)
G1		6
G2		6
G4		1
G5		1
G6		4
G7		1
G8		1
G9		1
G10		1
G11	 M5 bolt with nut	4
G12	 4x 25mm screw	8
G13	 4.2x 32mm screw	12
G14	 3x16mm screw	12
G15		2
G16		2

BOX 1/2		
NO.	Section	QTY(pcs)
G17		3
G18		24
G19		336+5
G20		168+5
G21		168+5
G22		168+2
G23		6
G27	 M3. 1*20	84
G28		18
G29	 M3. 8*20	18

BOX 2/2		
NO.	Section	QTY(pcs)
G3		84

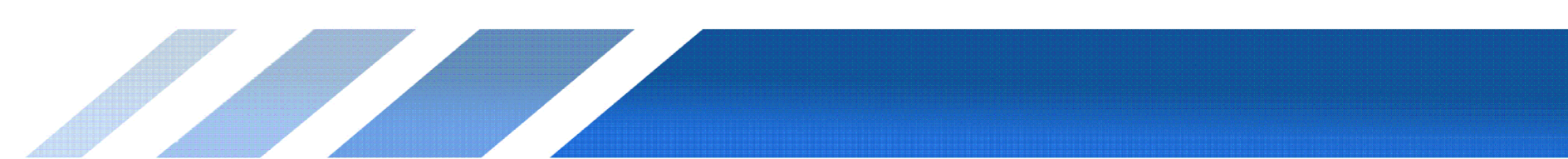



Item	Drawings		Qty
G1			6
G2			6
G3			84
G4			1
G5			1
G6			4
G7			1
G8			1
G9			1
G10			1
G11		M5 bolt with nut	4
G12		4x 25mm screw	8
G13		4.2x 32mm screw	12
G14		3x16mm screw	12
G15			2

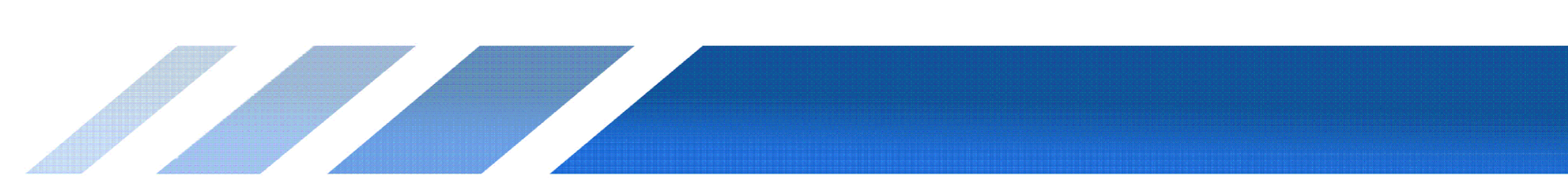

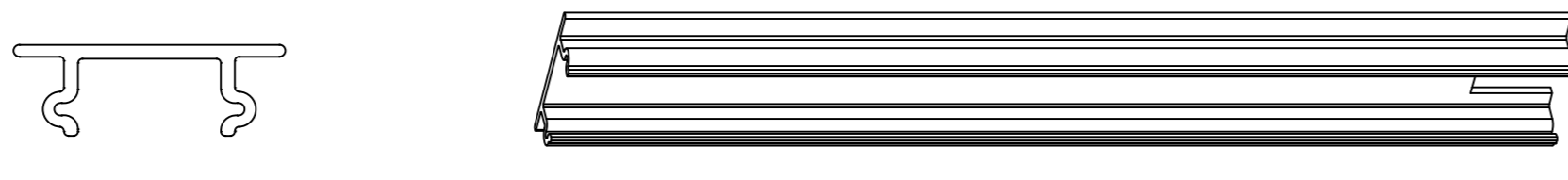
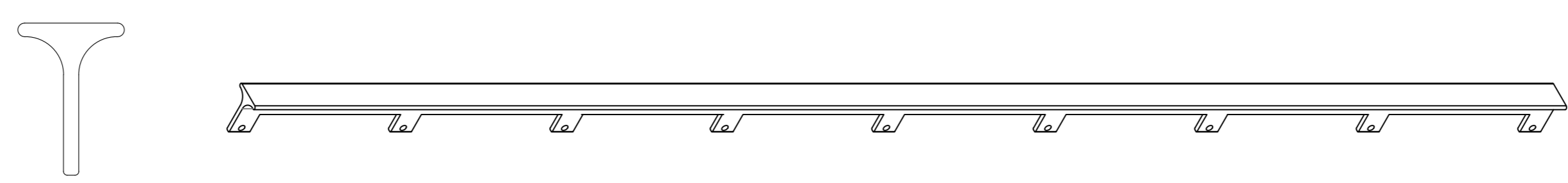
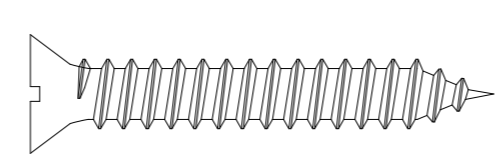
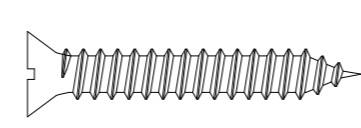
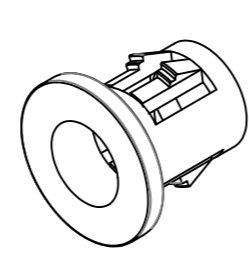
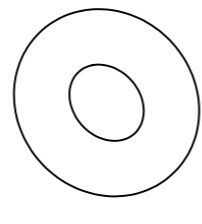
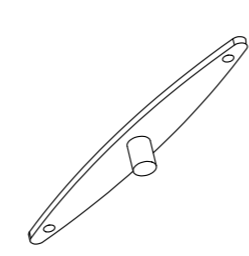
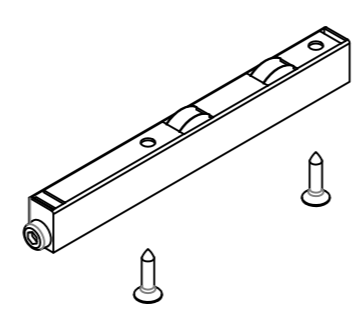
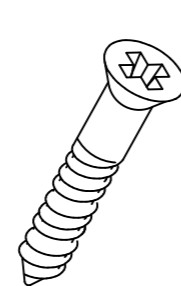
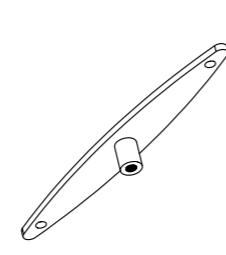
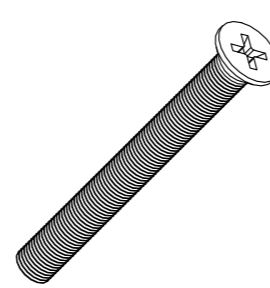

Item	Drawings	Qty
G16		2
G17		3
G18	 M3. 9*45	24
G19	 M2. 9*19	252+5
G20		168+5
G21		168+5
G22		150+2
G23		6
G27	 M3. 1*20	84+2
G28		18
G29	 M3. 8*20	18

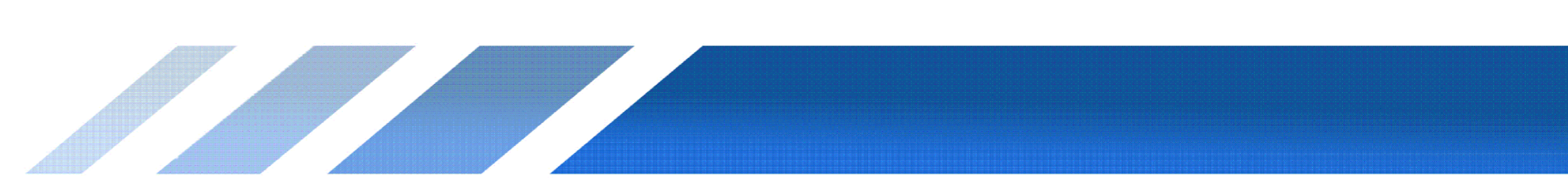

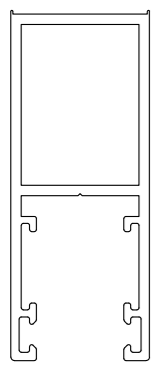

[G1]

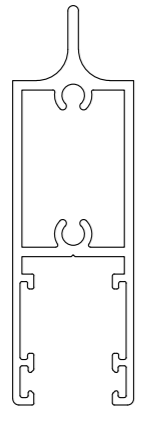

[G2]



[G3]

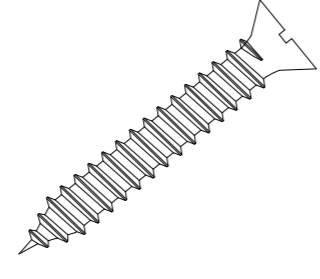

[G18]

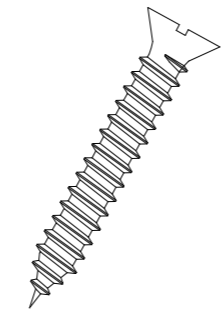

[G19]

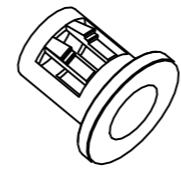

[G20]



[G22]

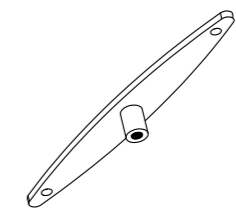

[G28]

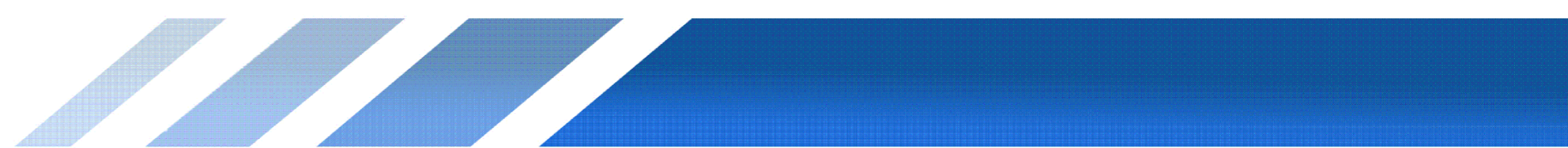
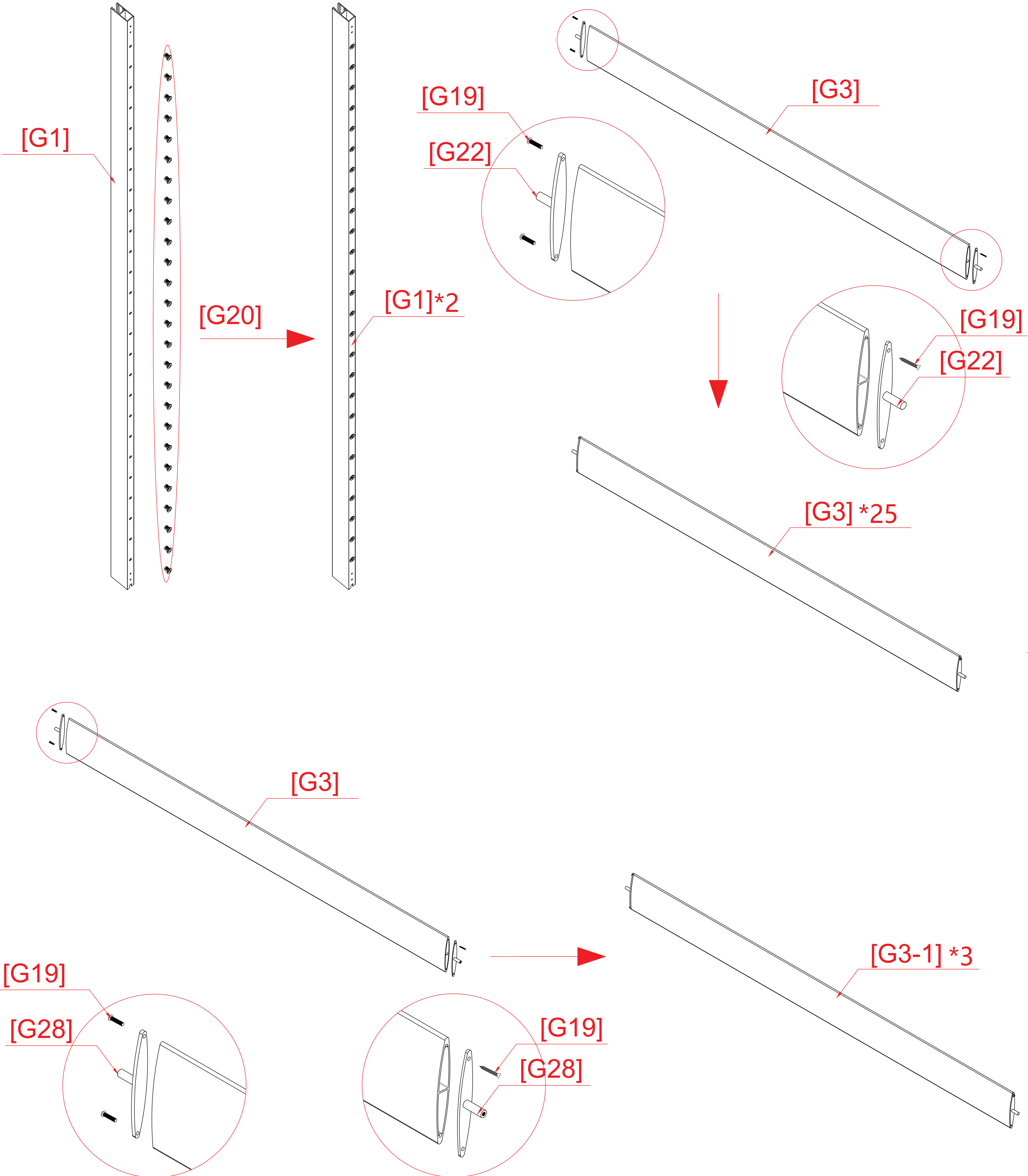



[G21]

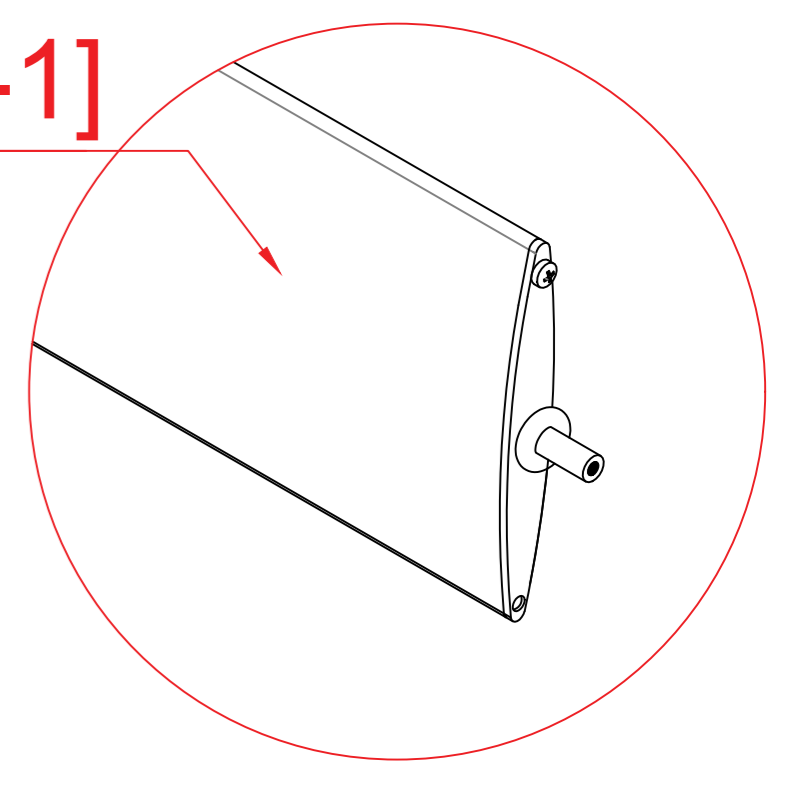
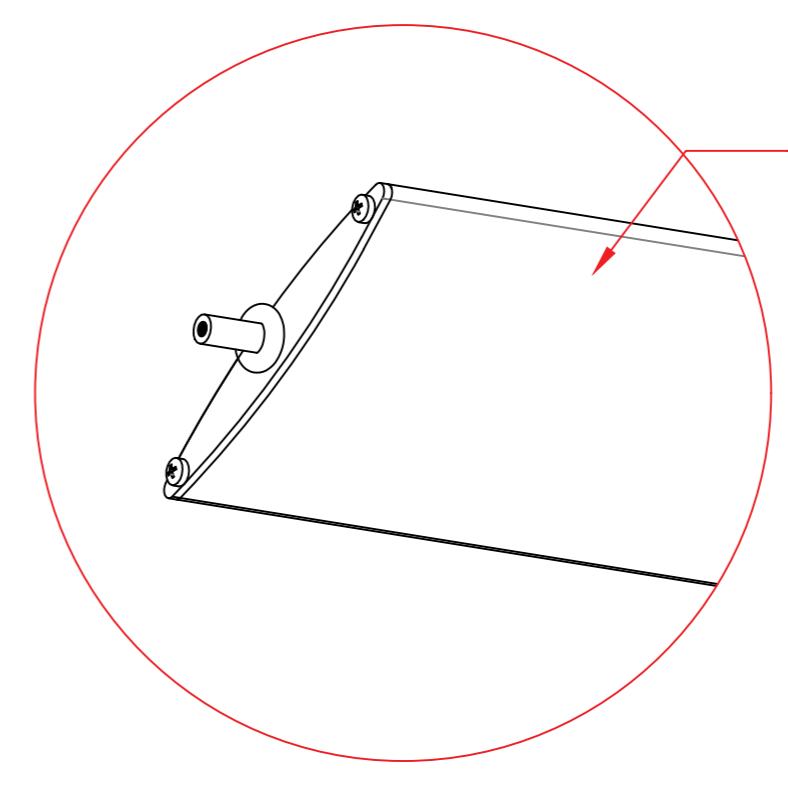
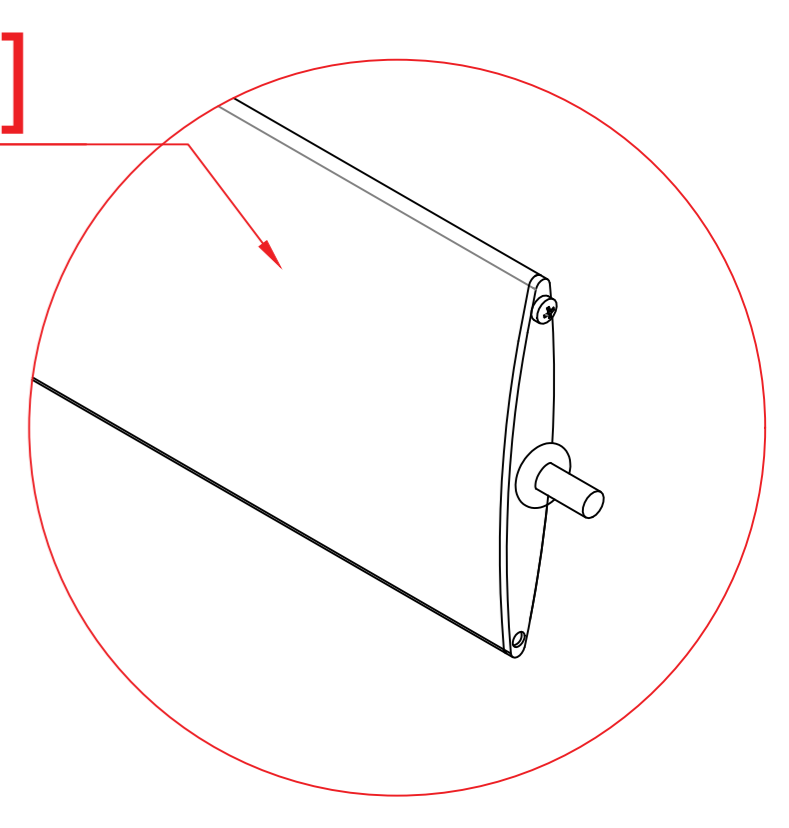
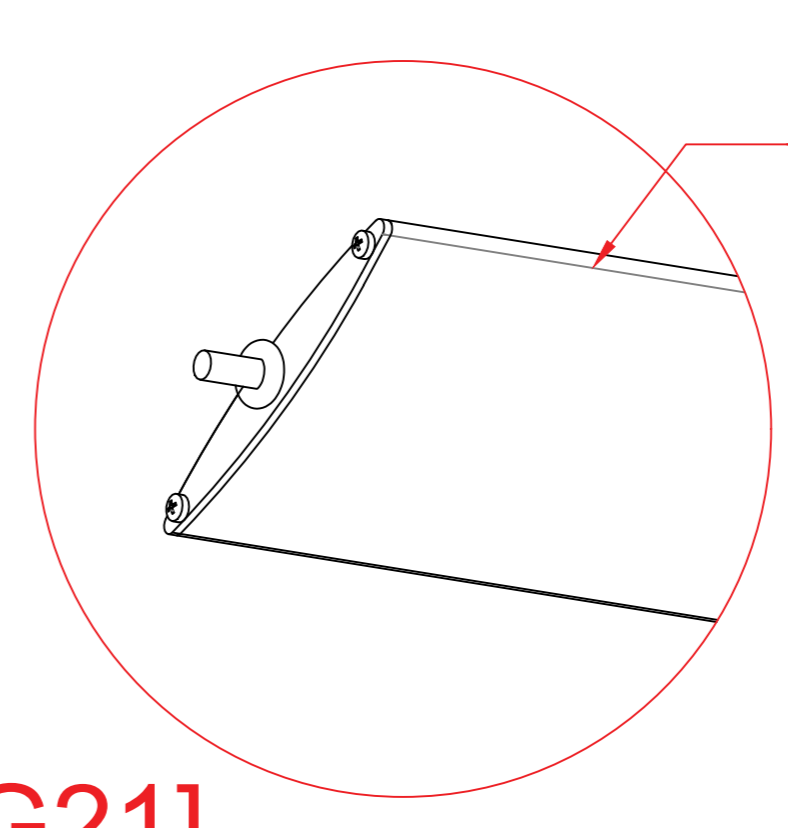
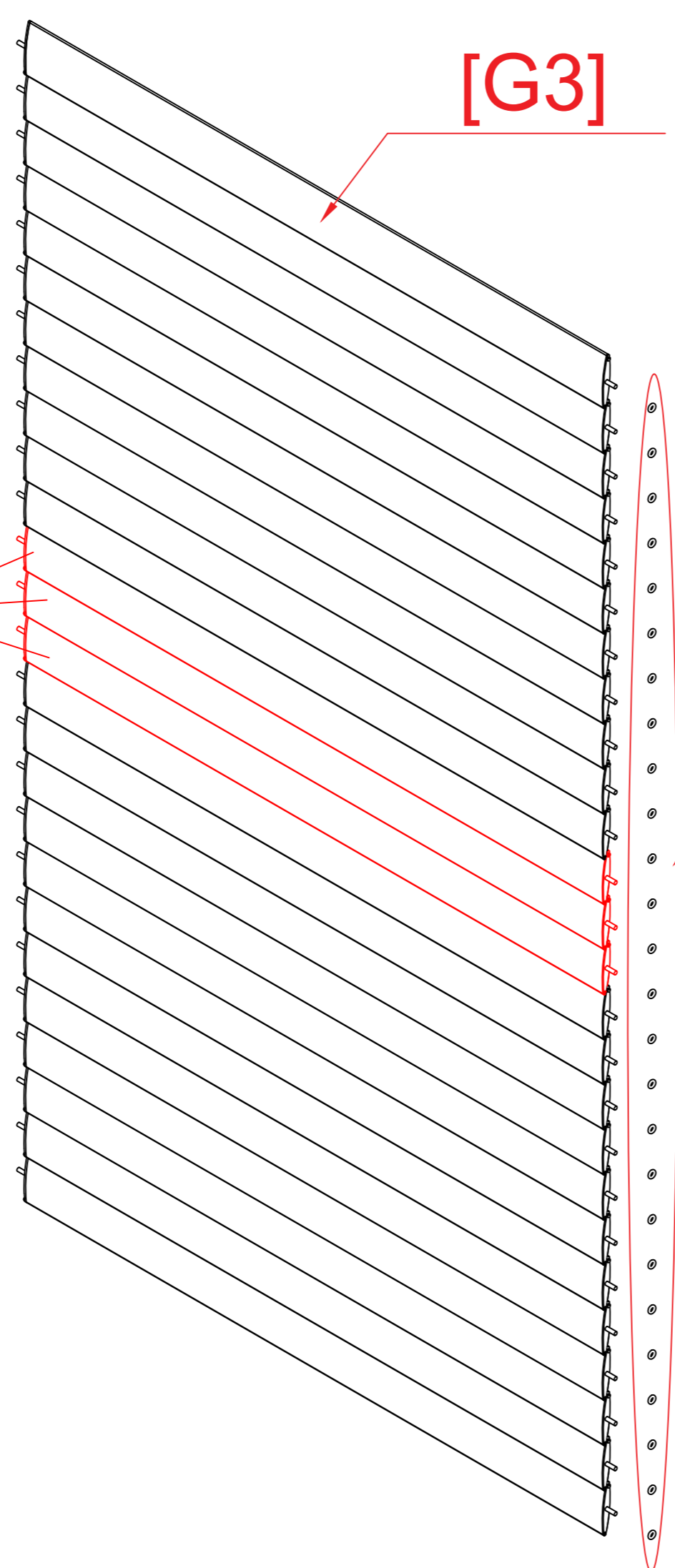
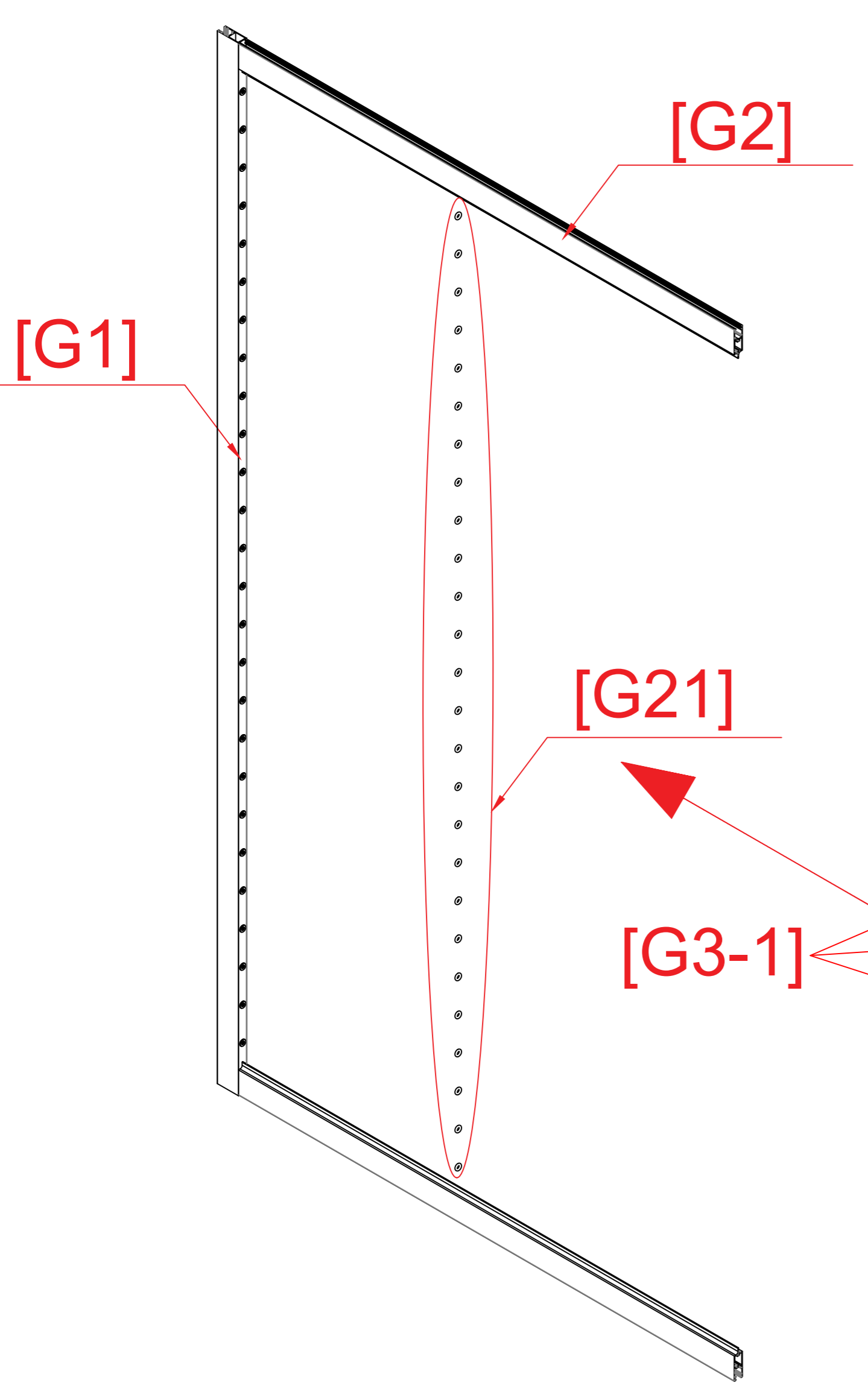
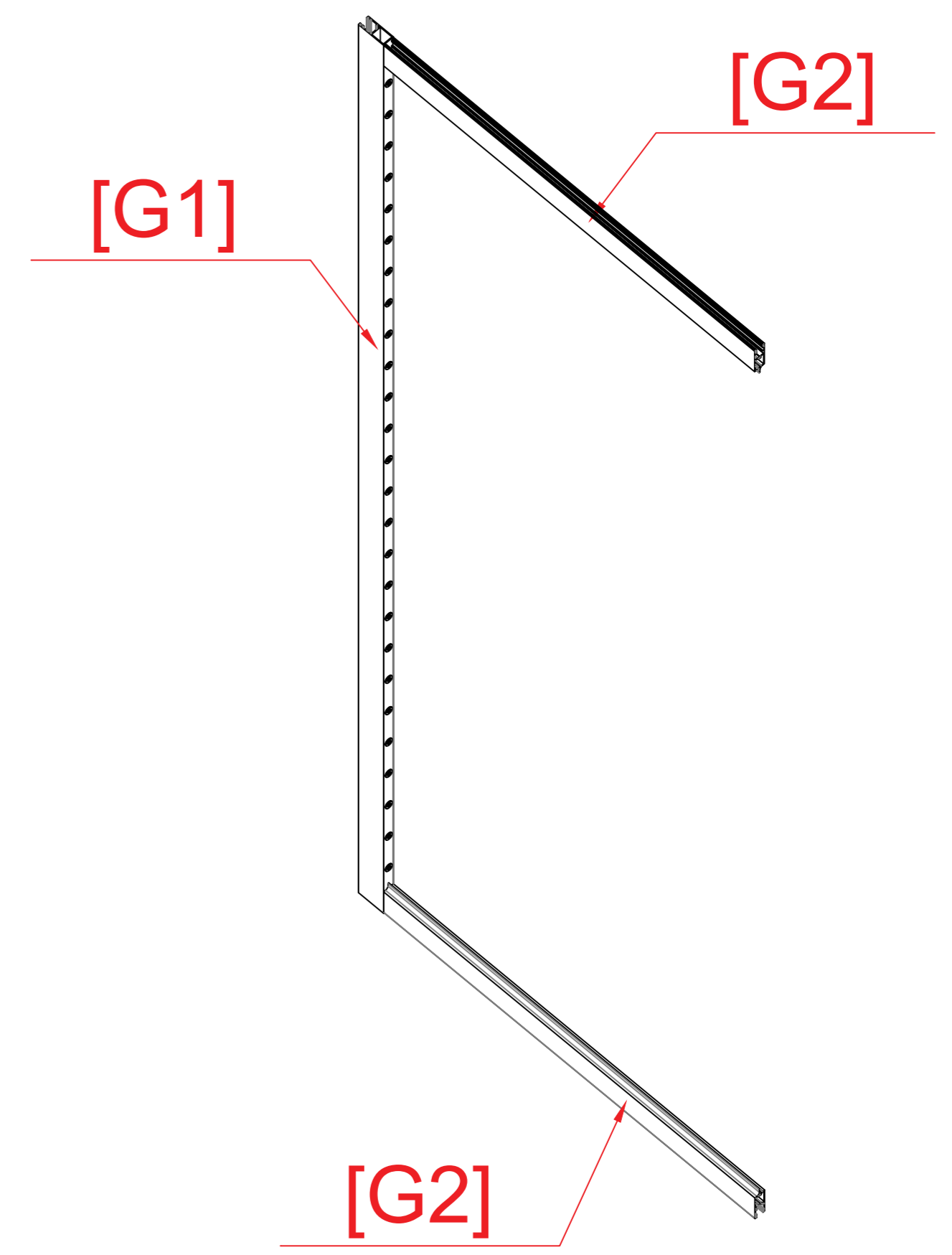
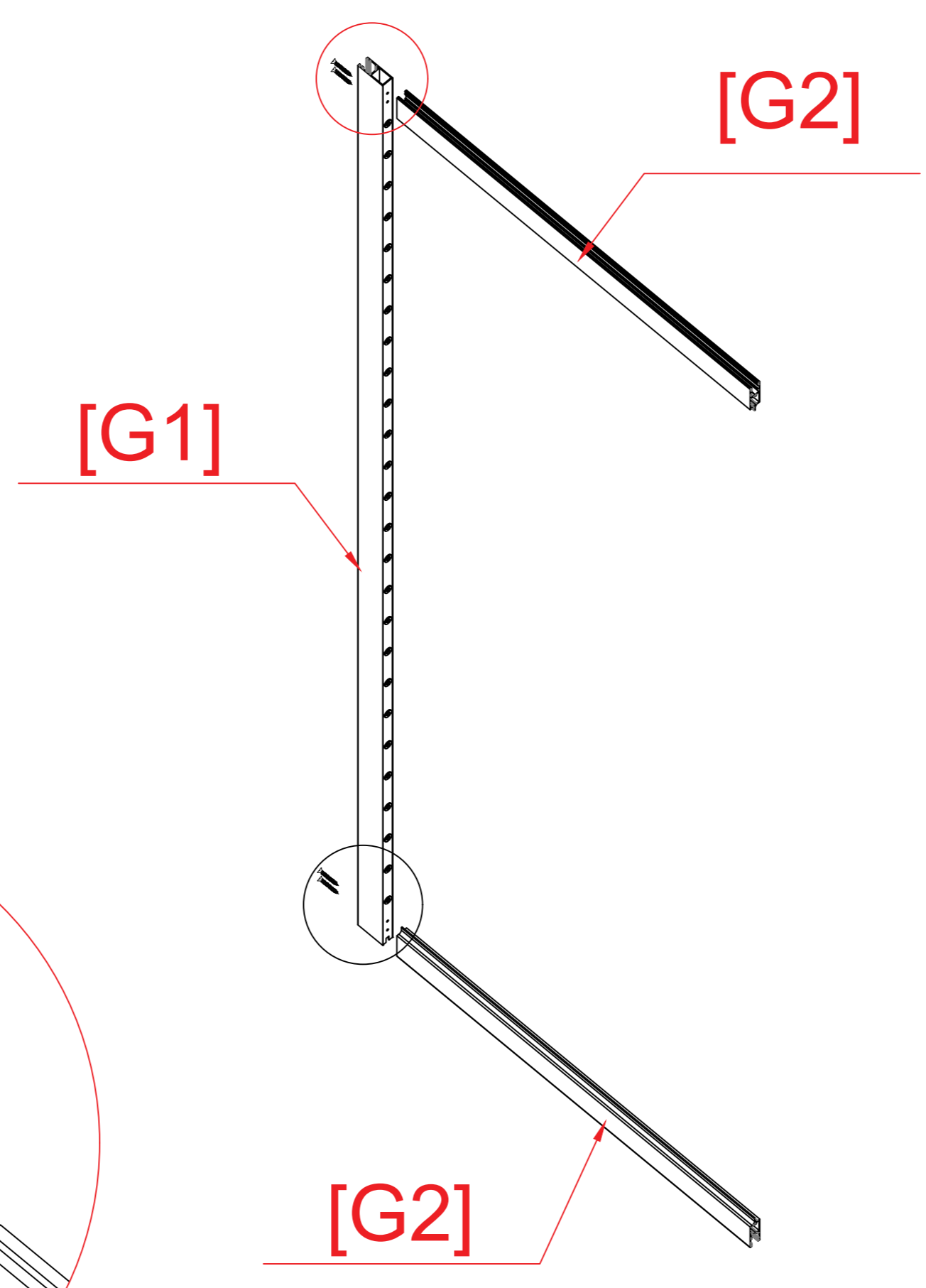
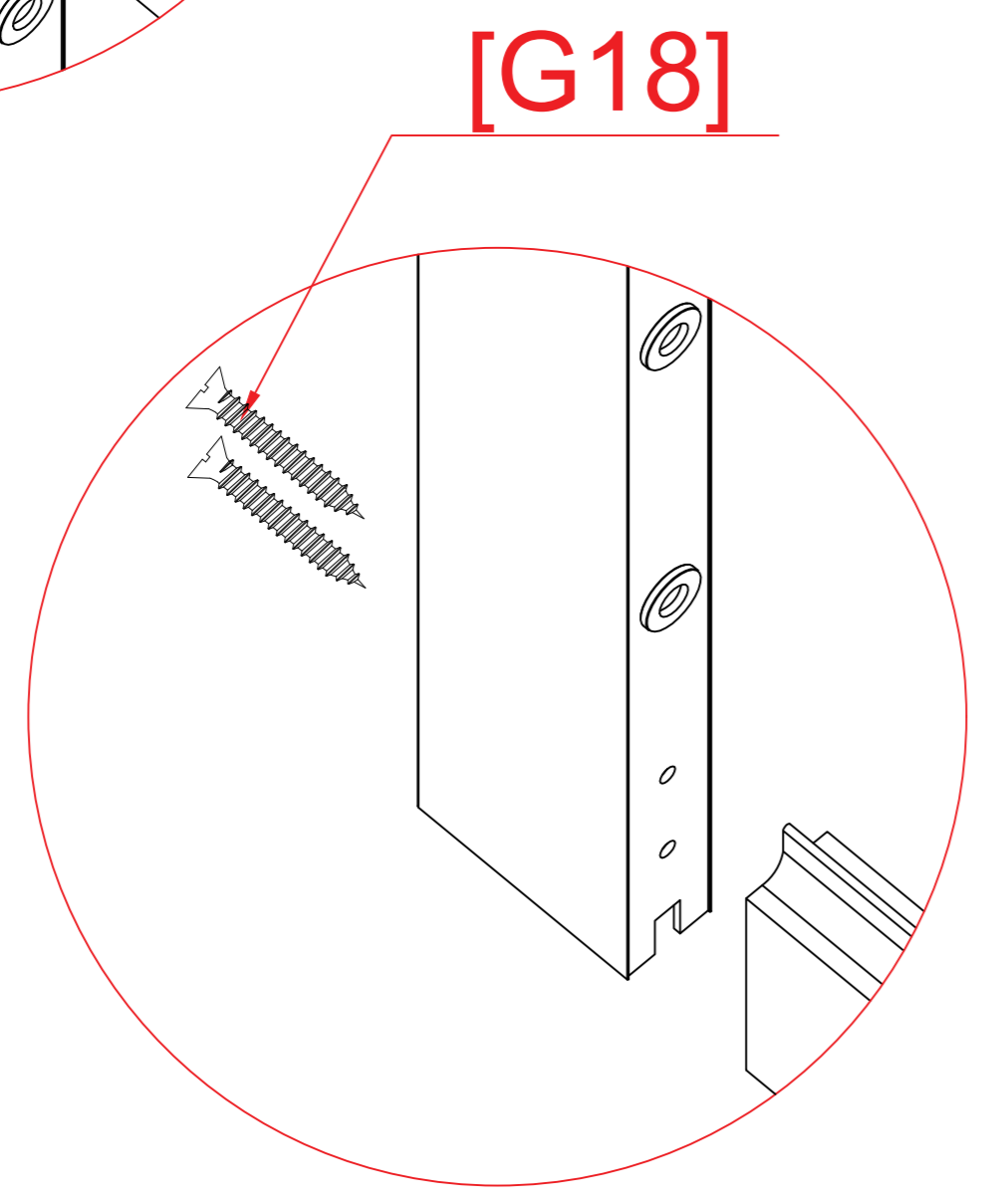
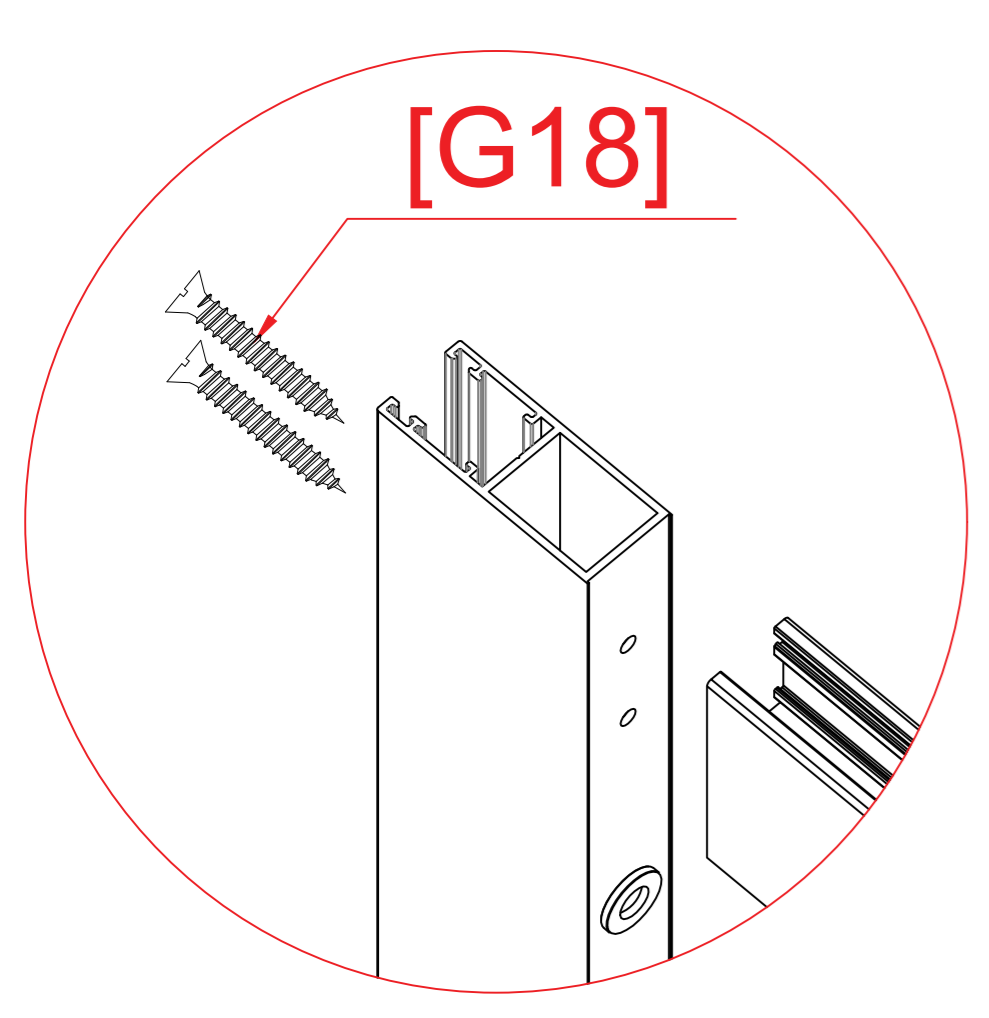

[G3-1] * 3 is in the middle

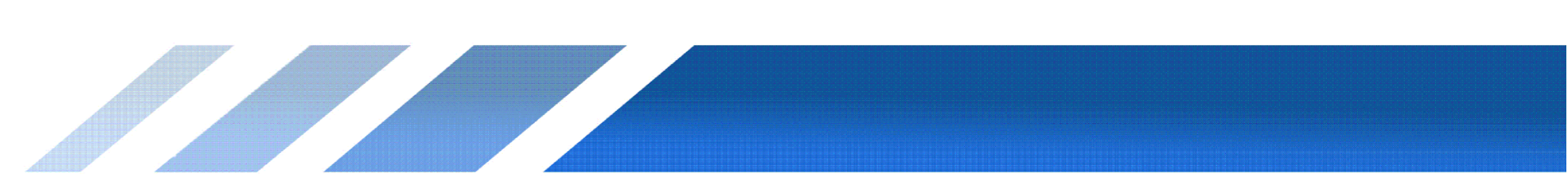



[G1]

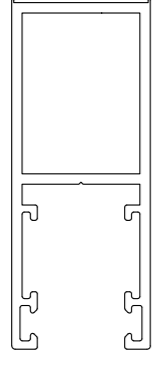

[G18]

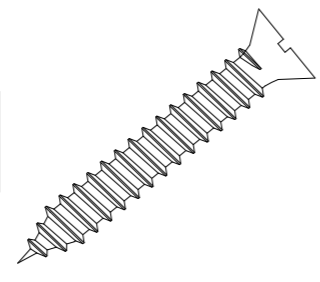

[G29]

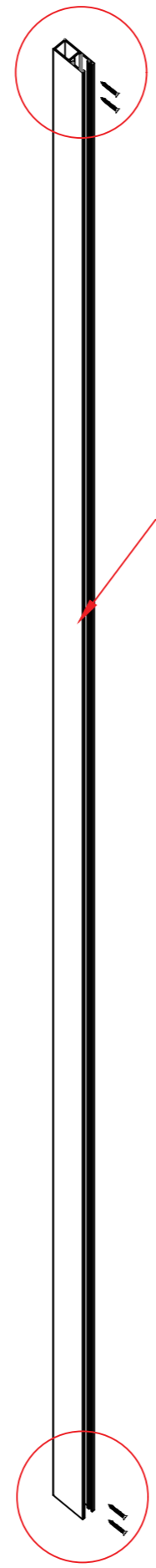
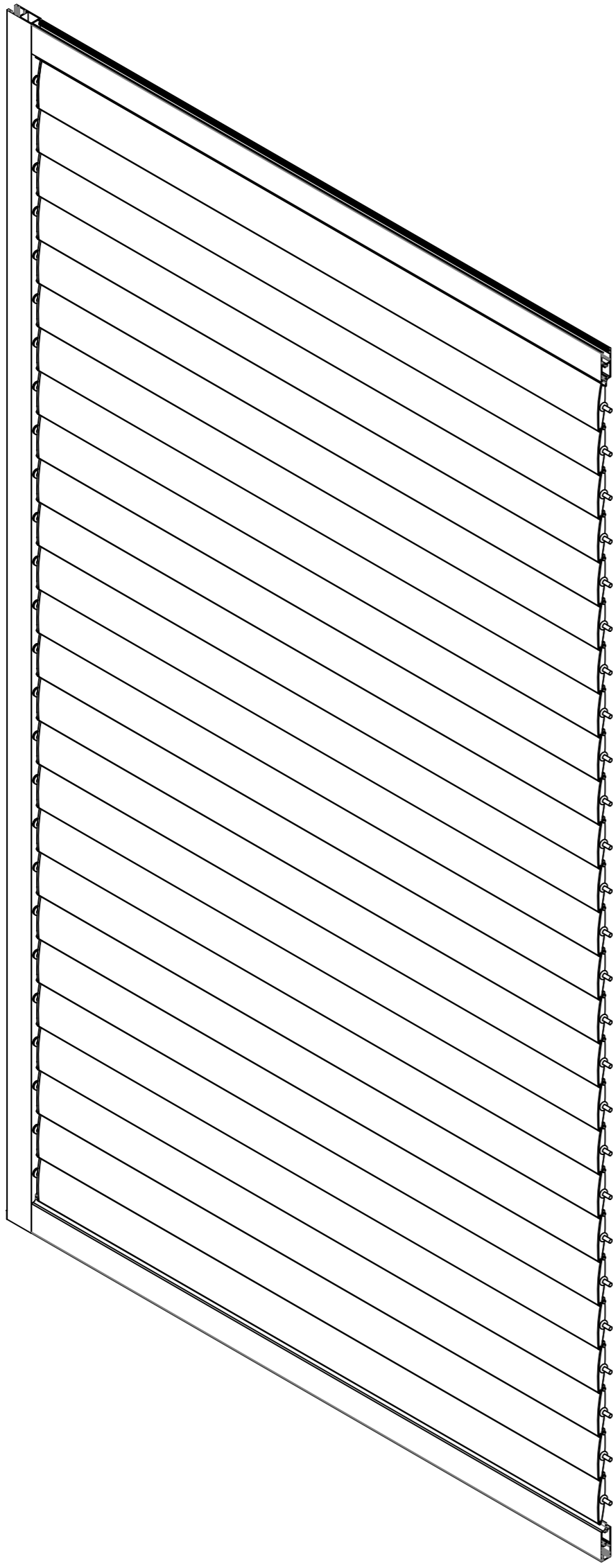
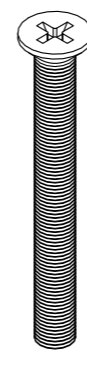

[G1]

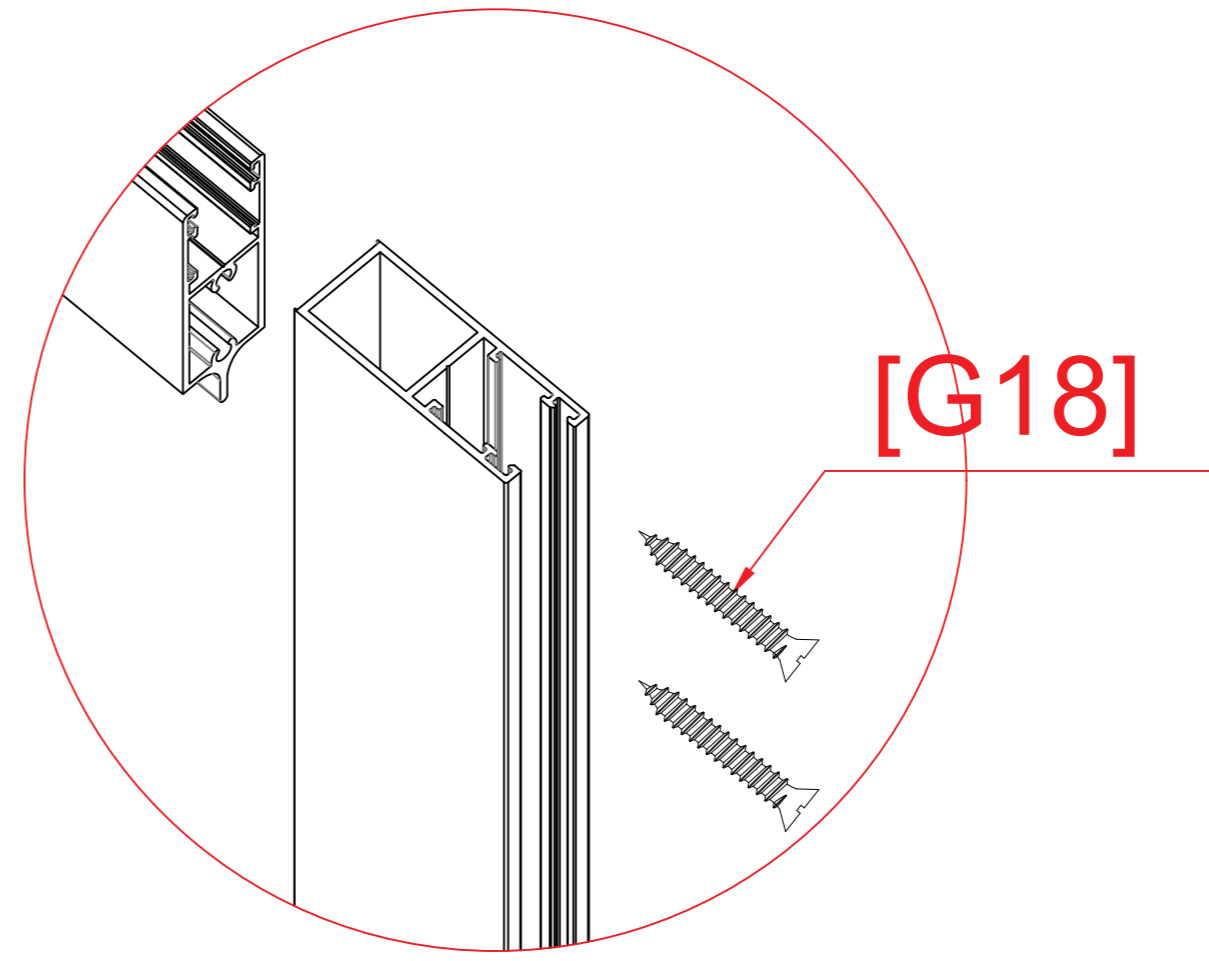

[G18]

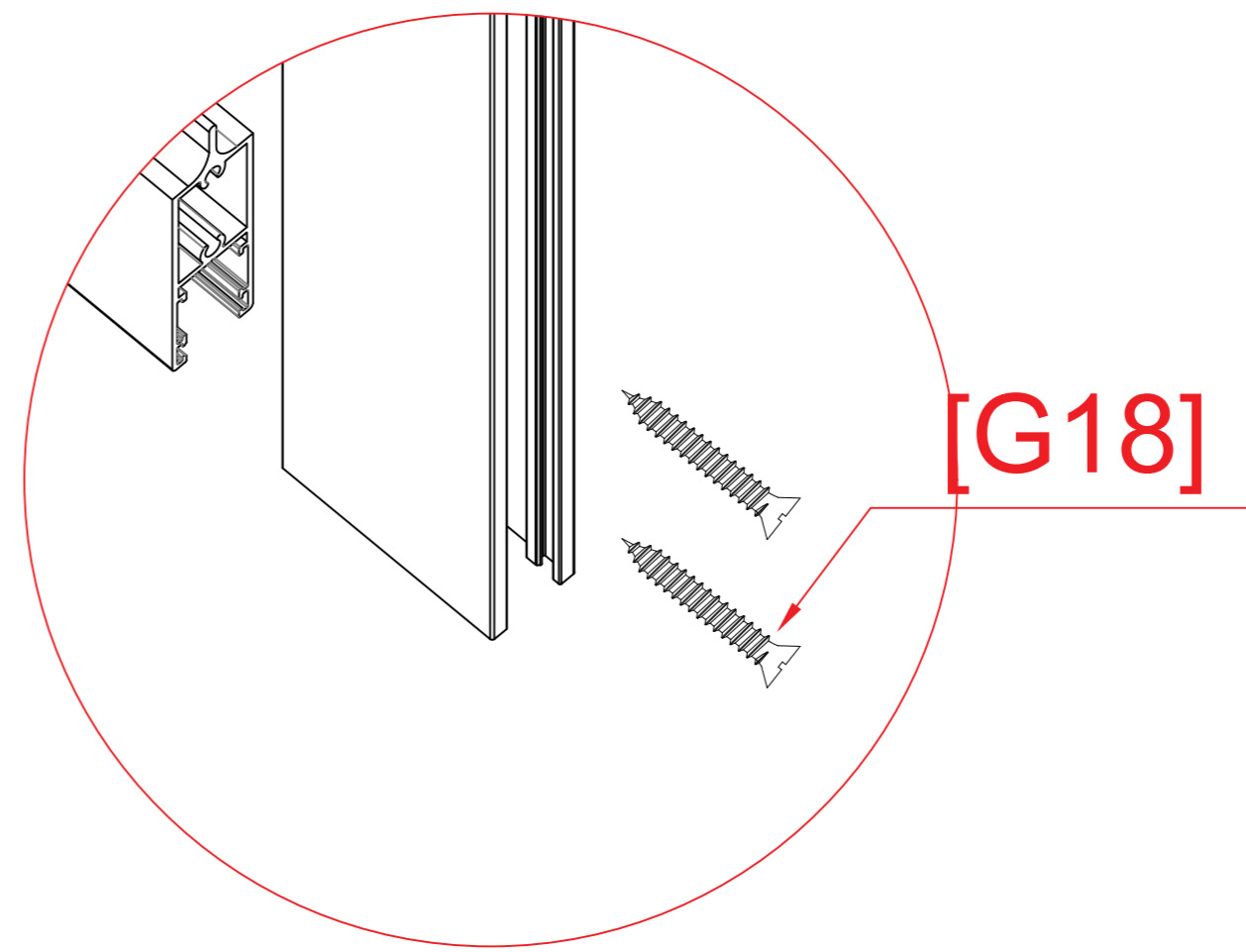

[G18]

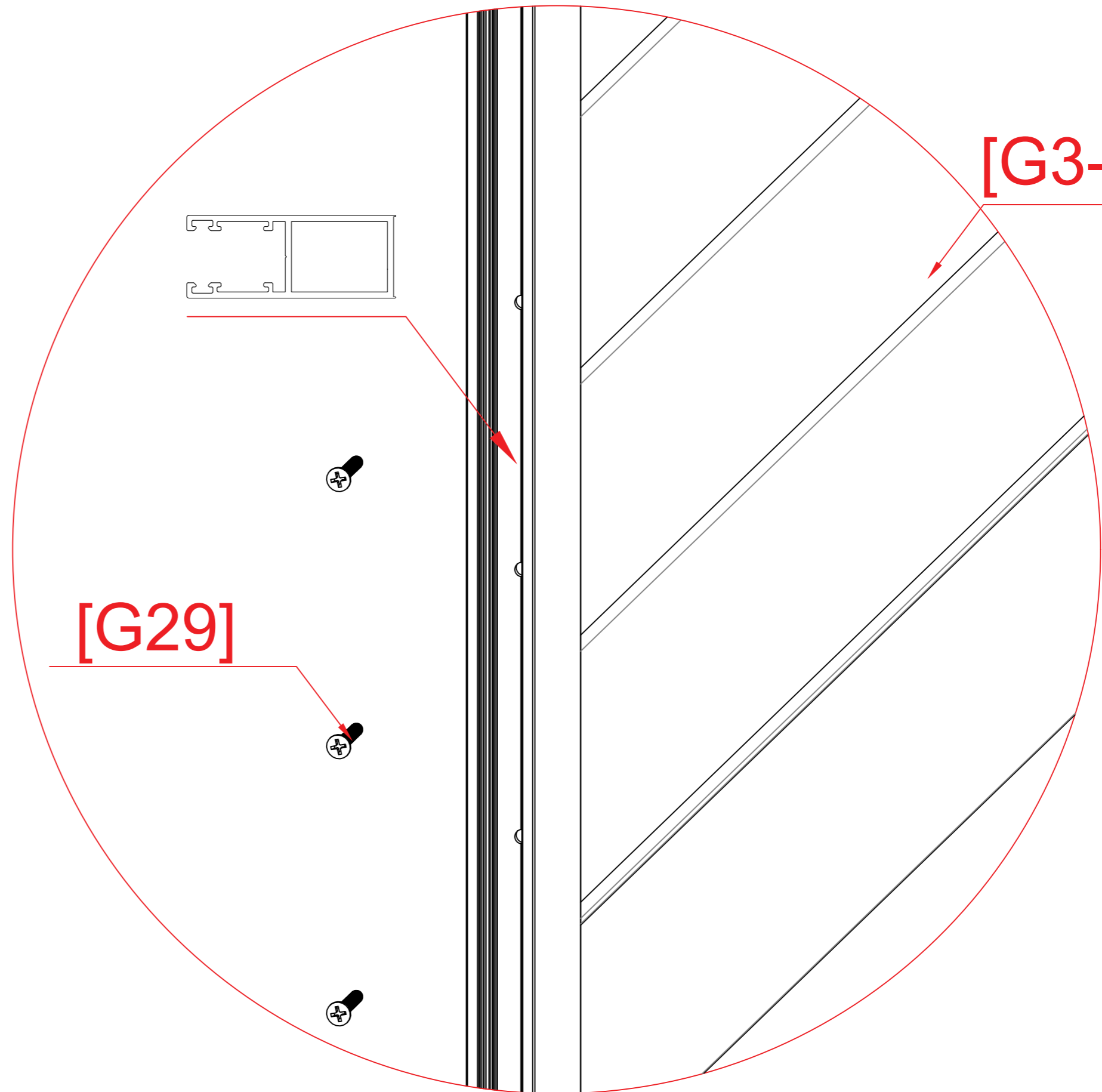
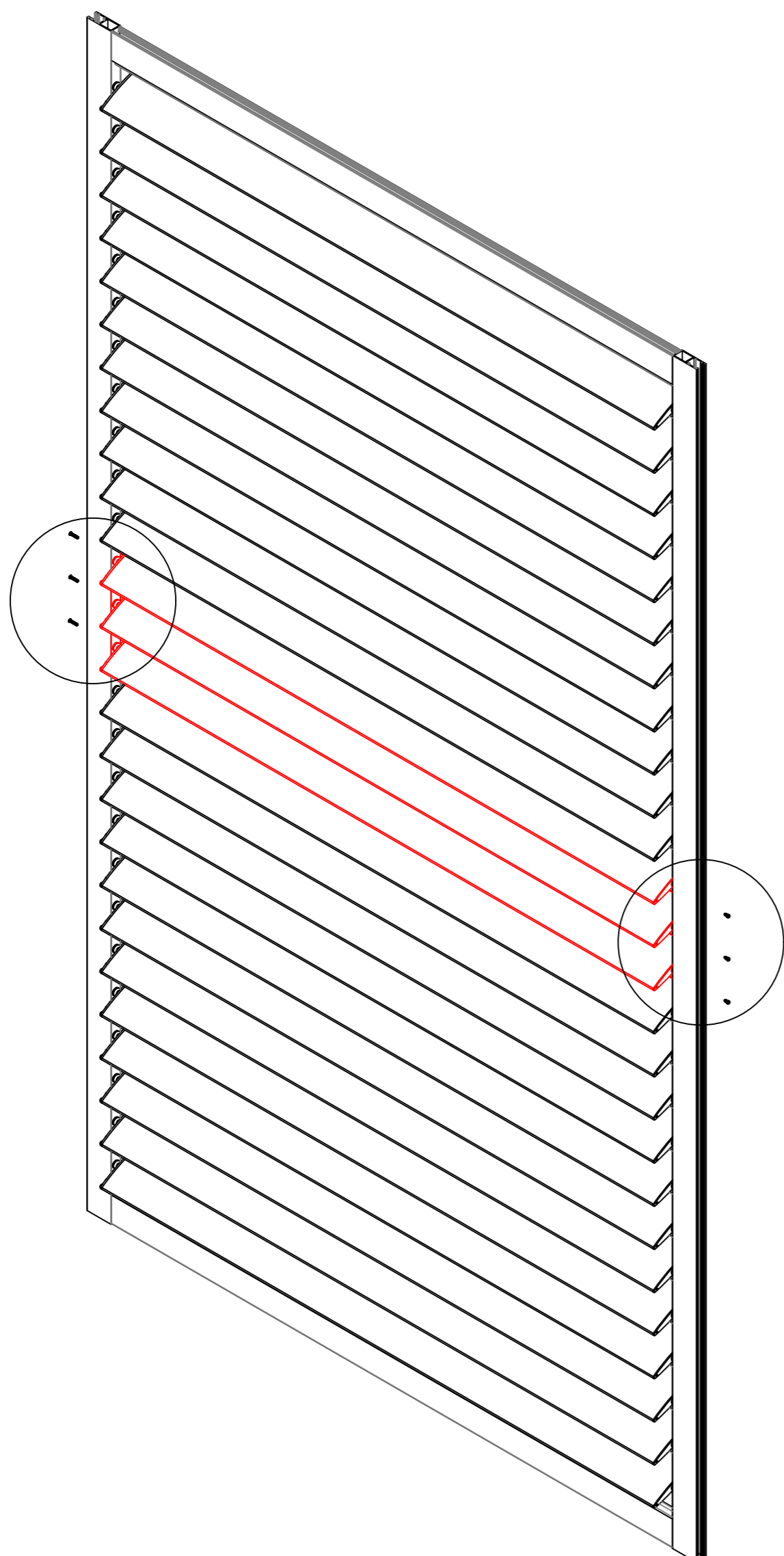

[G3-1]*3

[G29]

[G3-1] * 3 is in the middle, and after installation, both ends are tightened with bolts from the reserved holes.

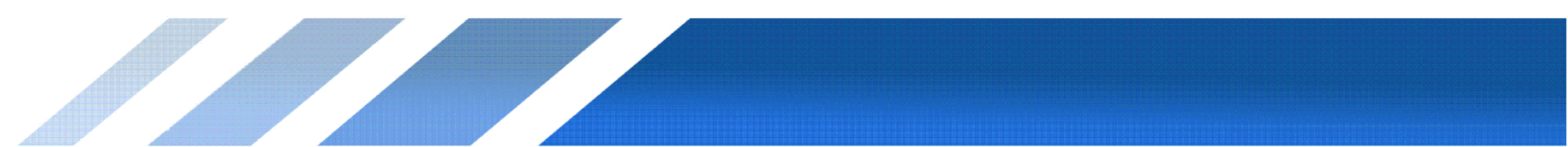



[G17]

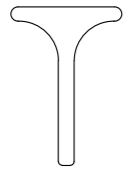

[G19]

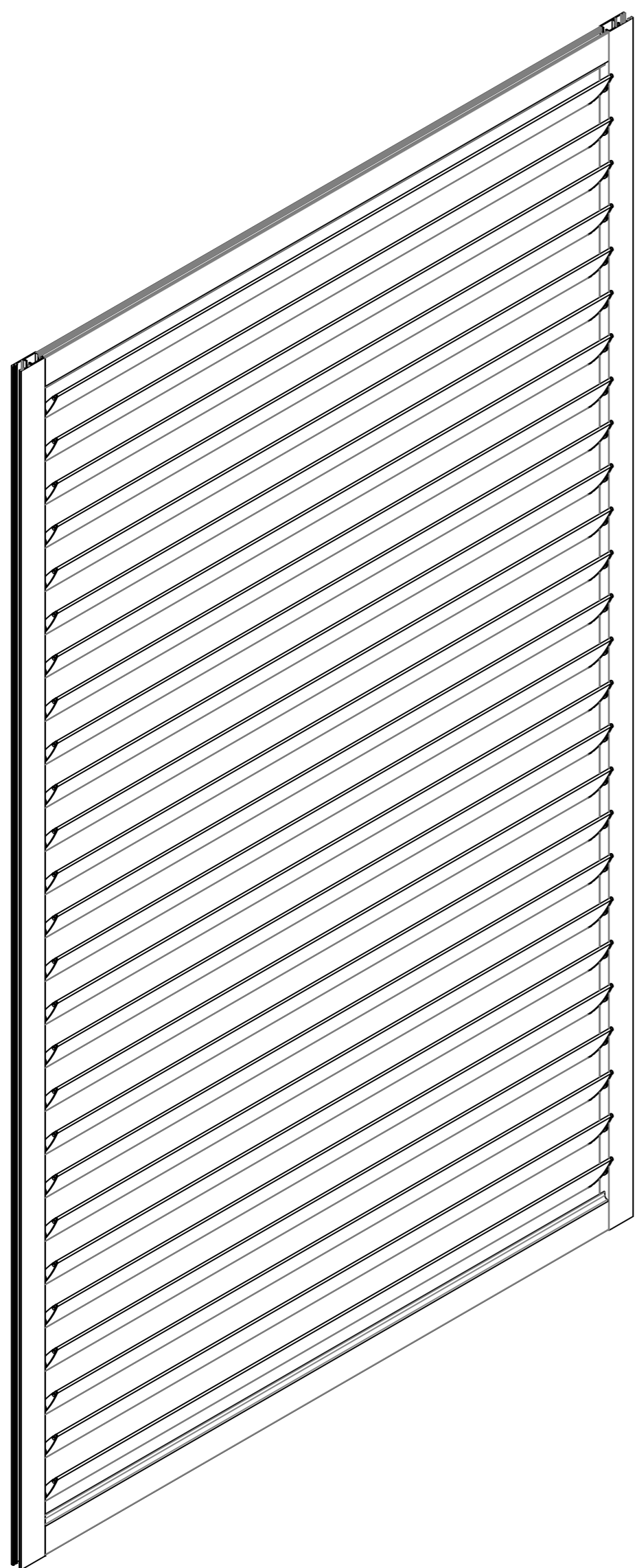
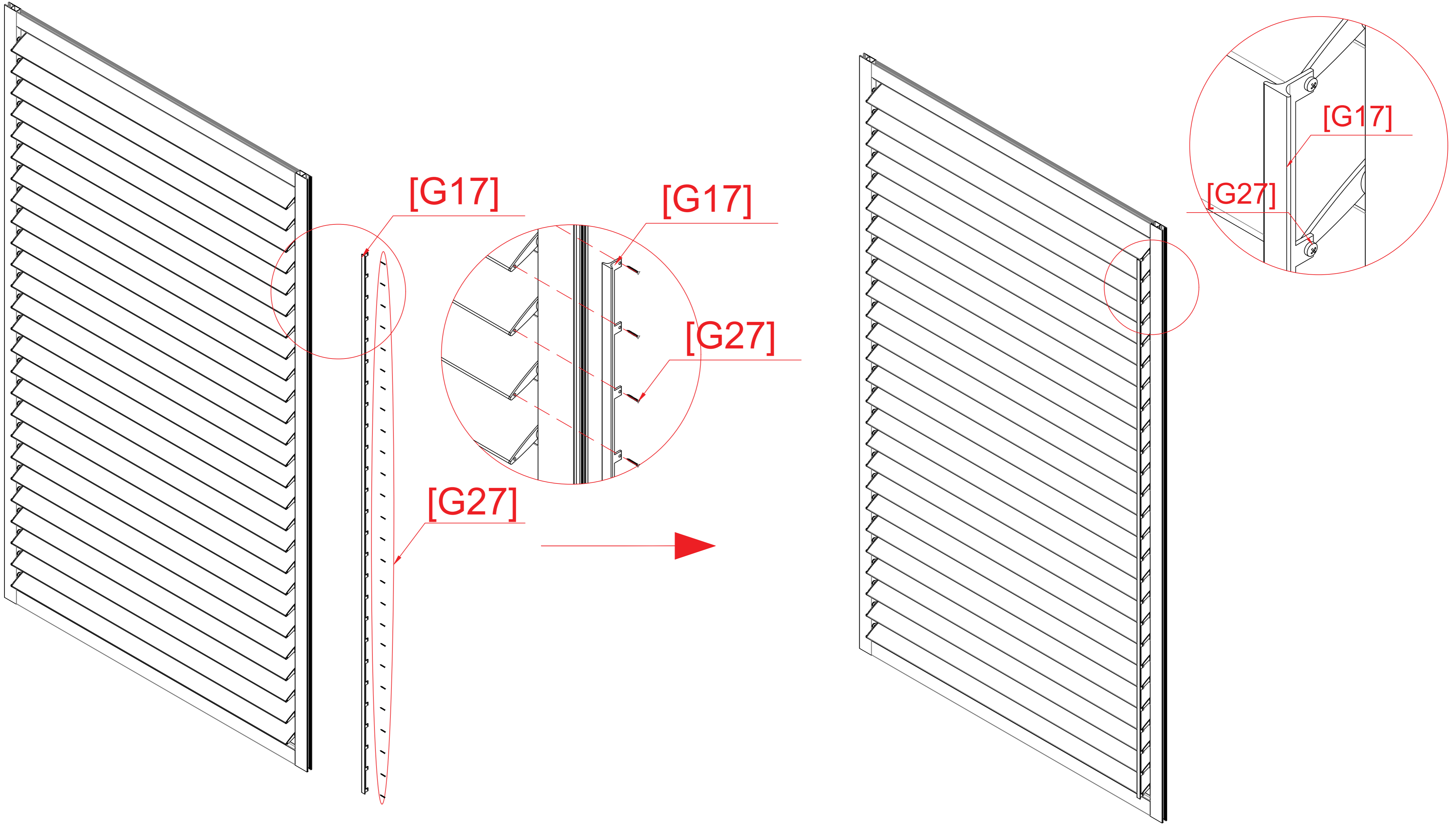
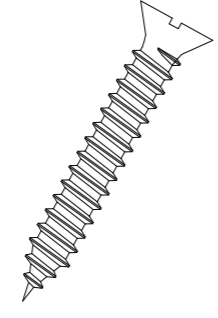

A

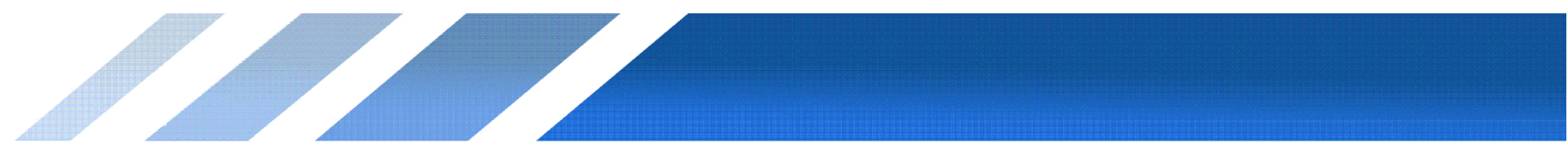
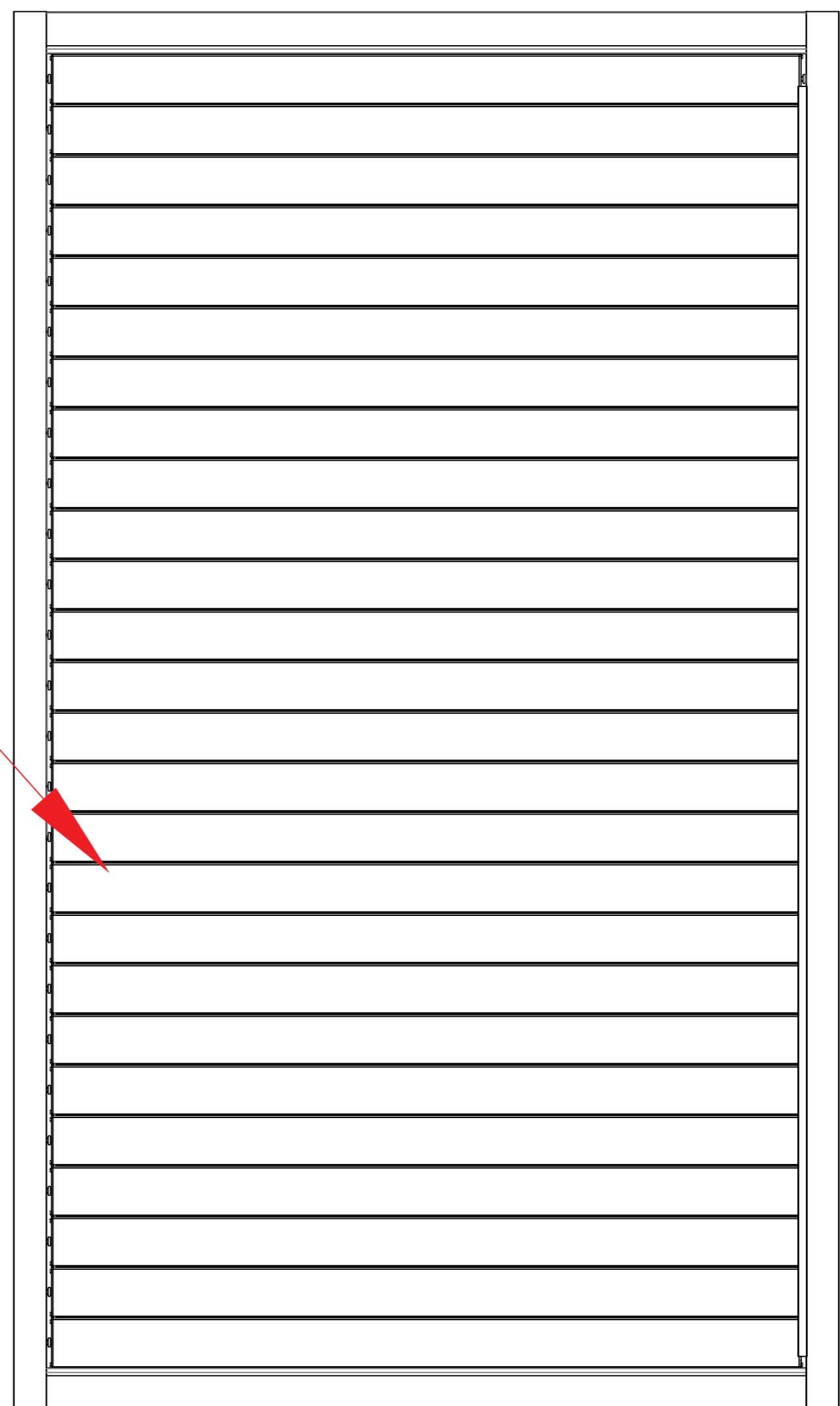

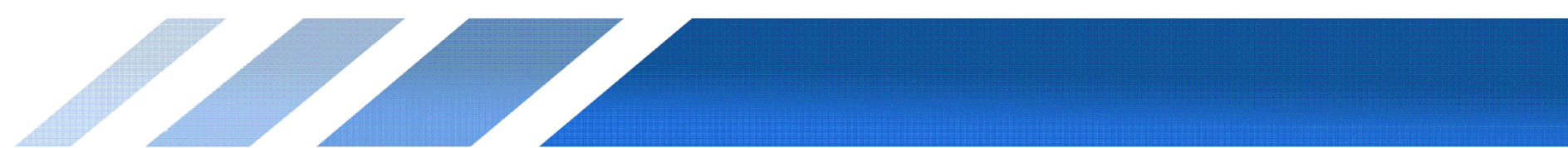
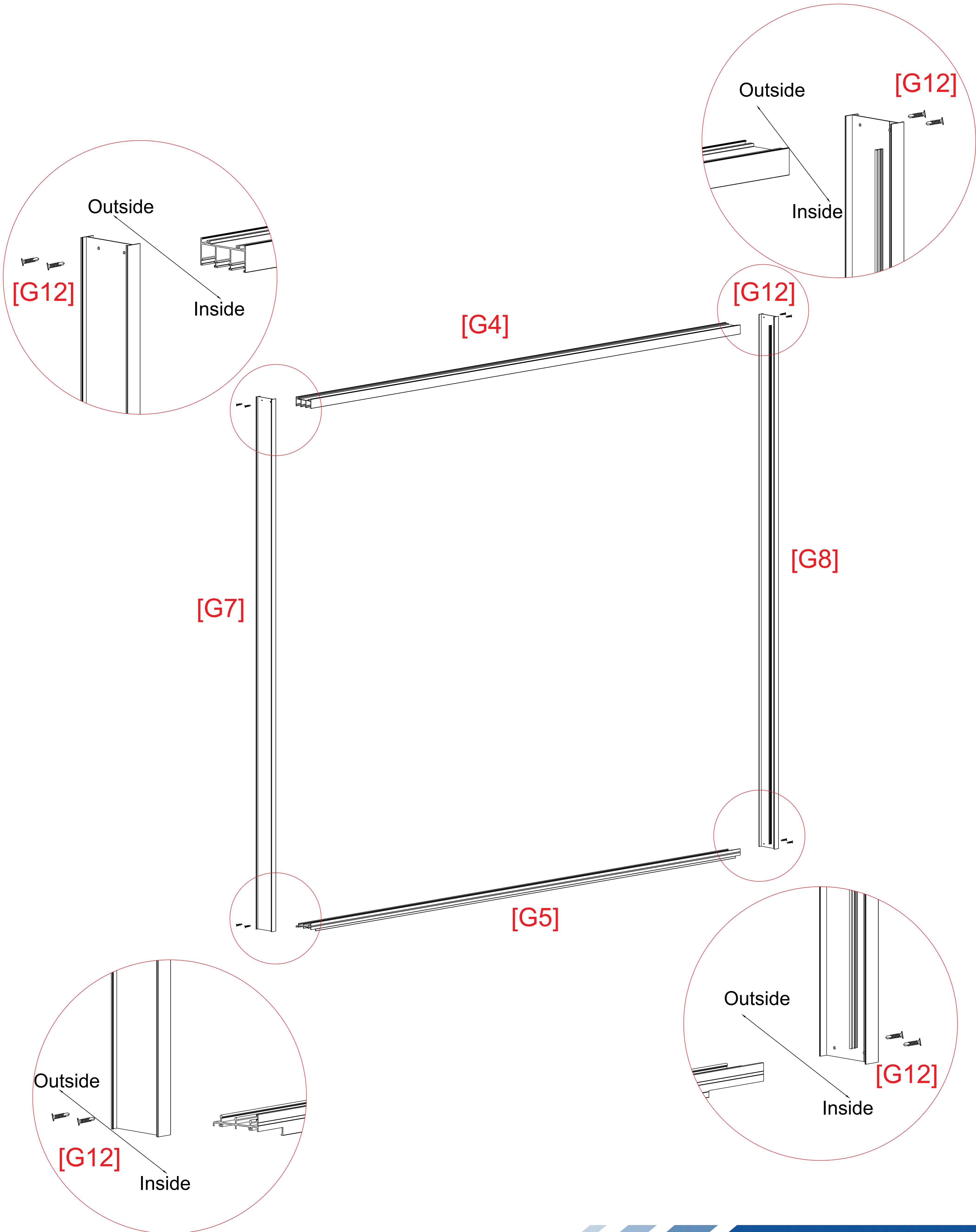
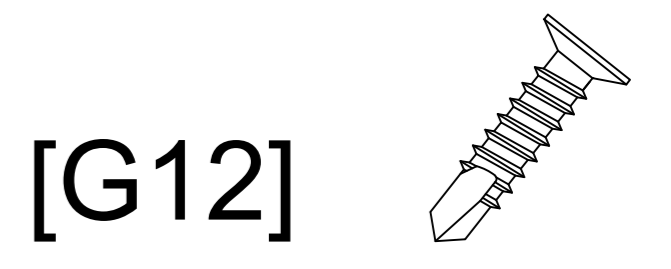
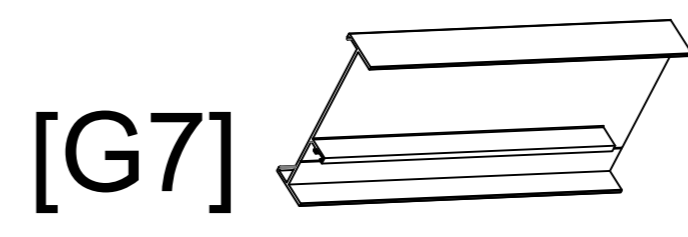
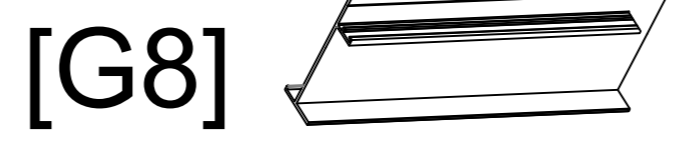
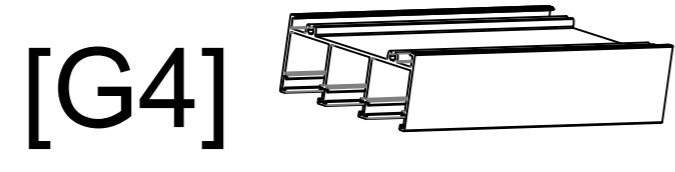
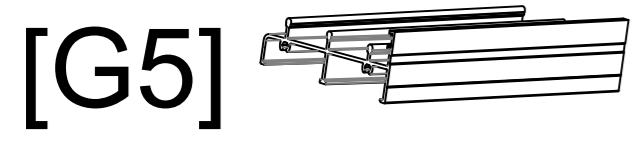

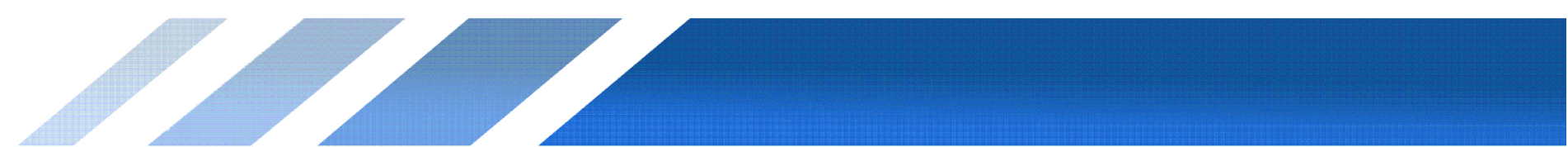
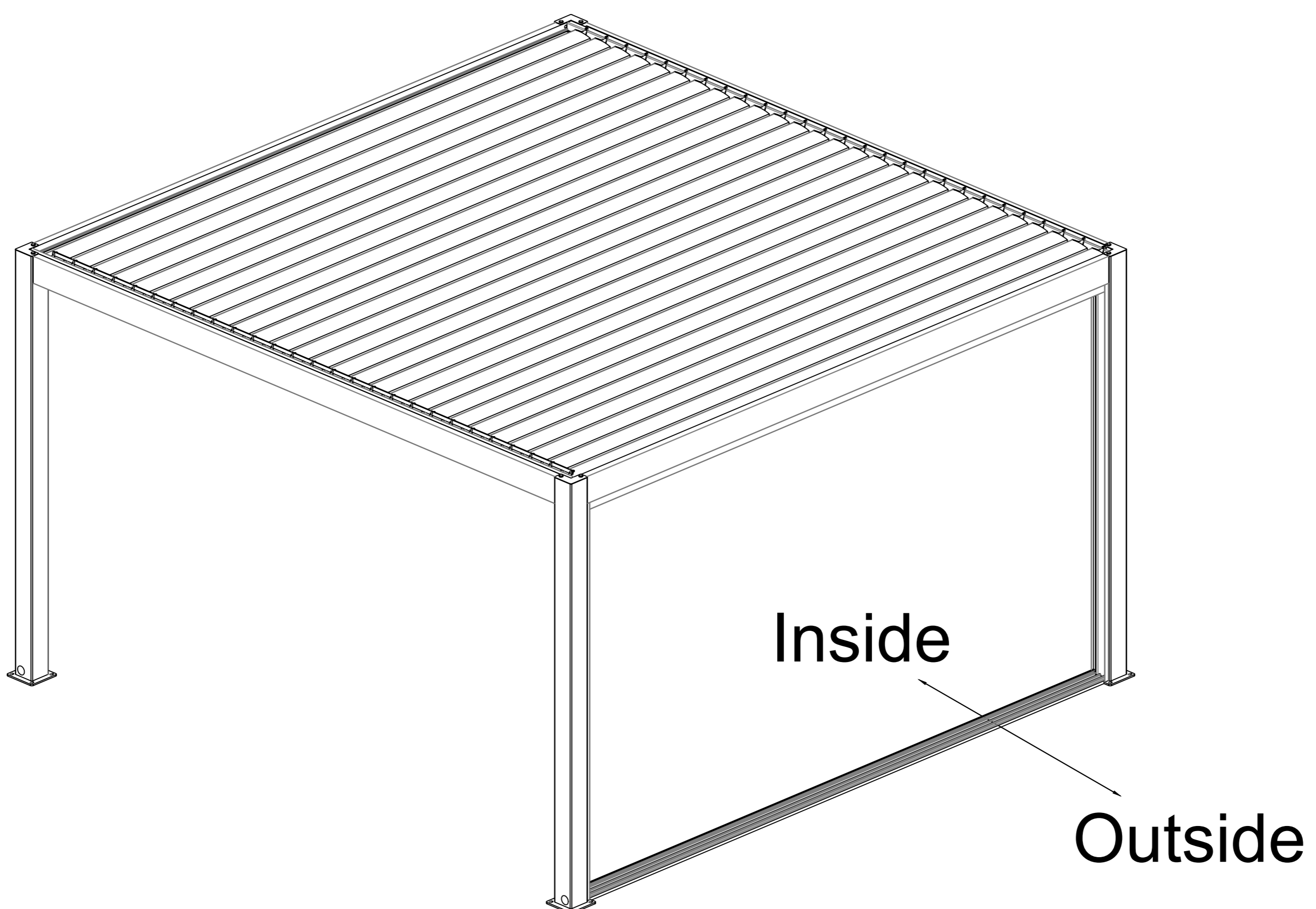
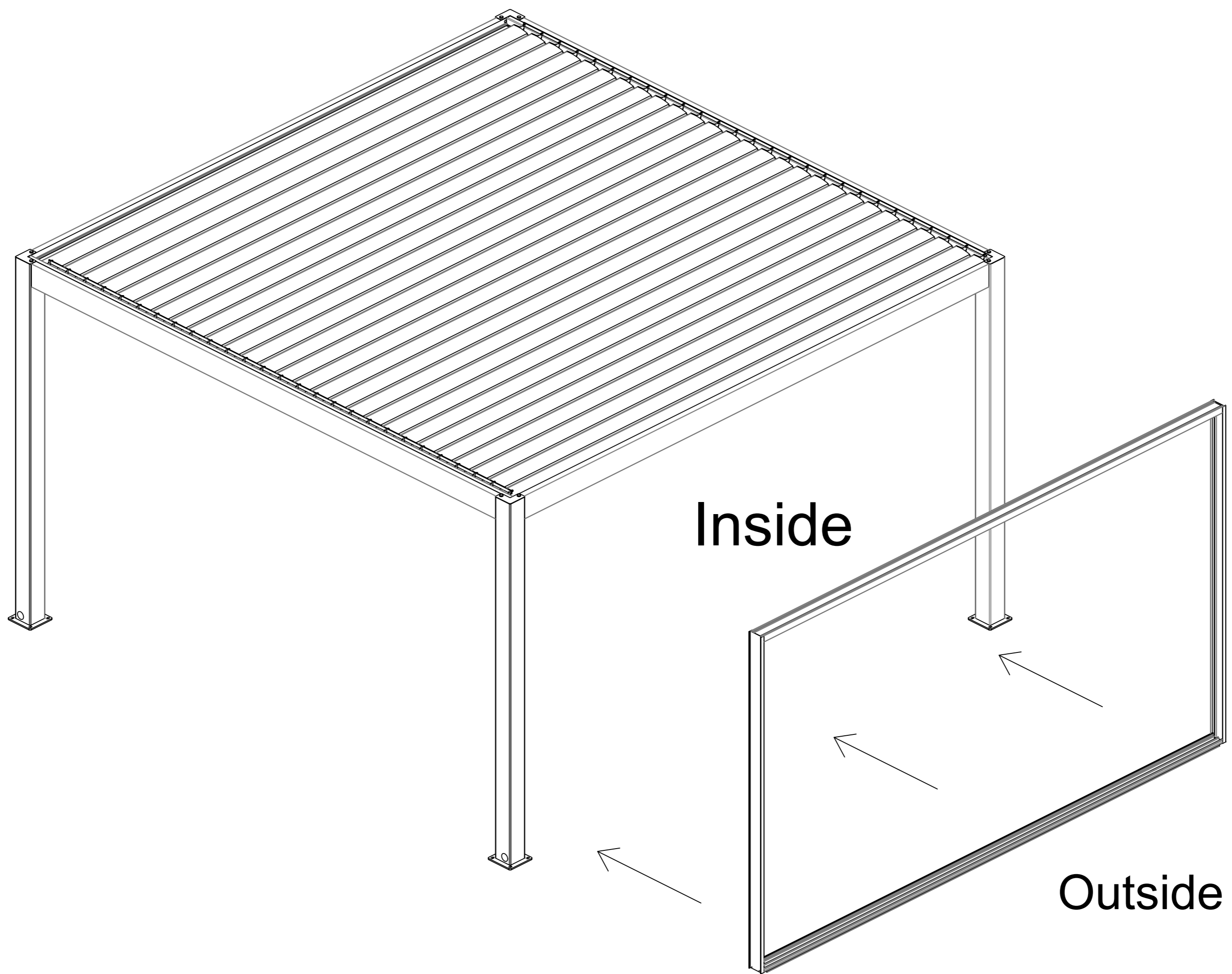

[G13]×12

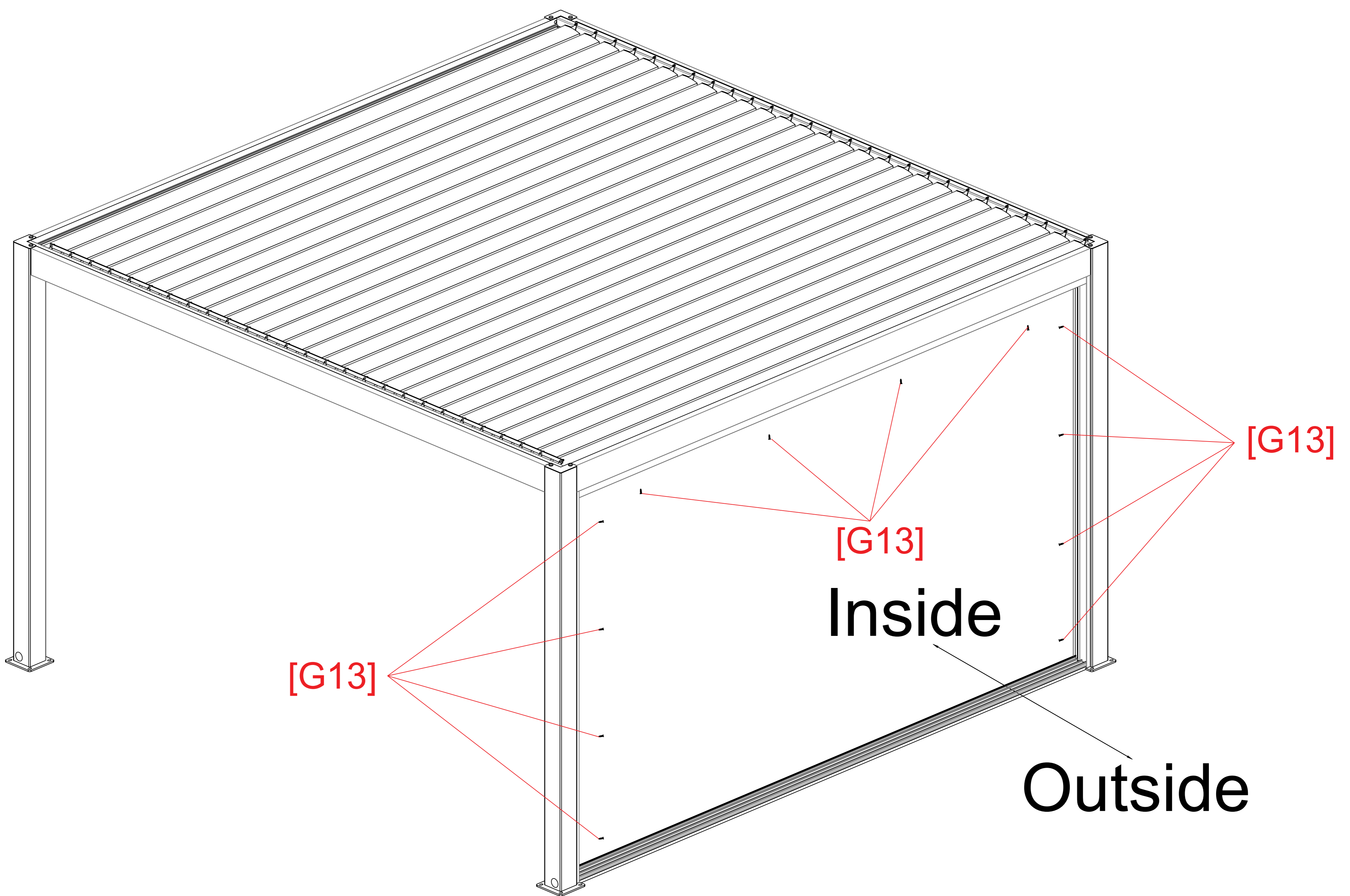
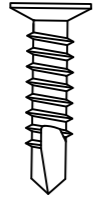

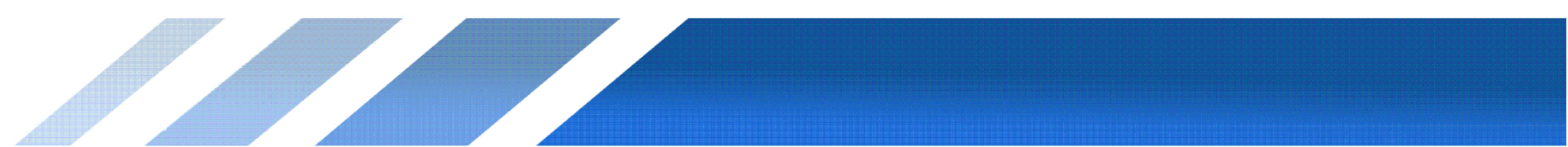
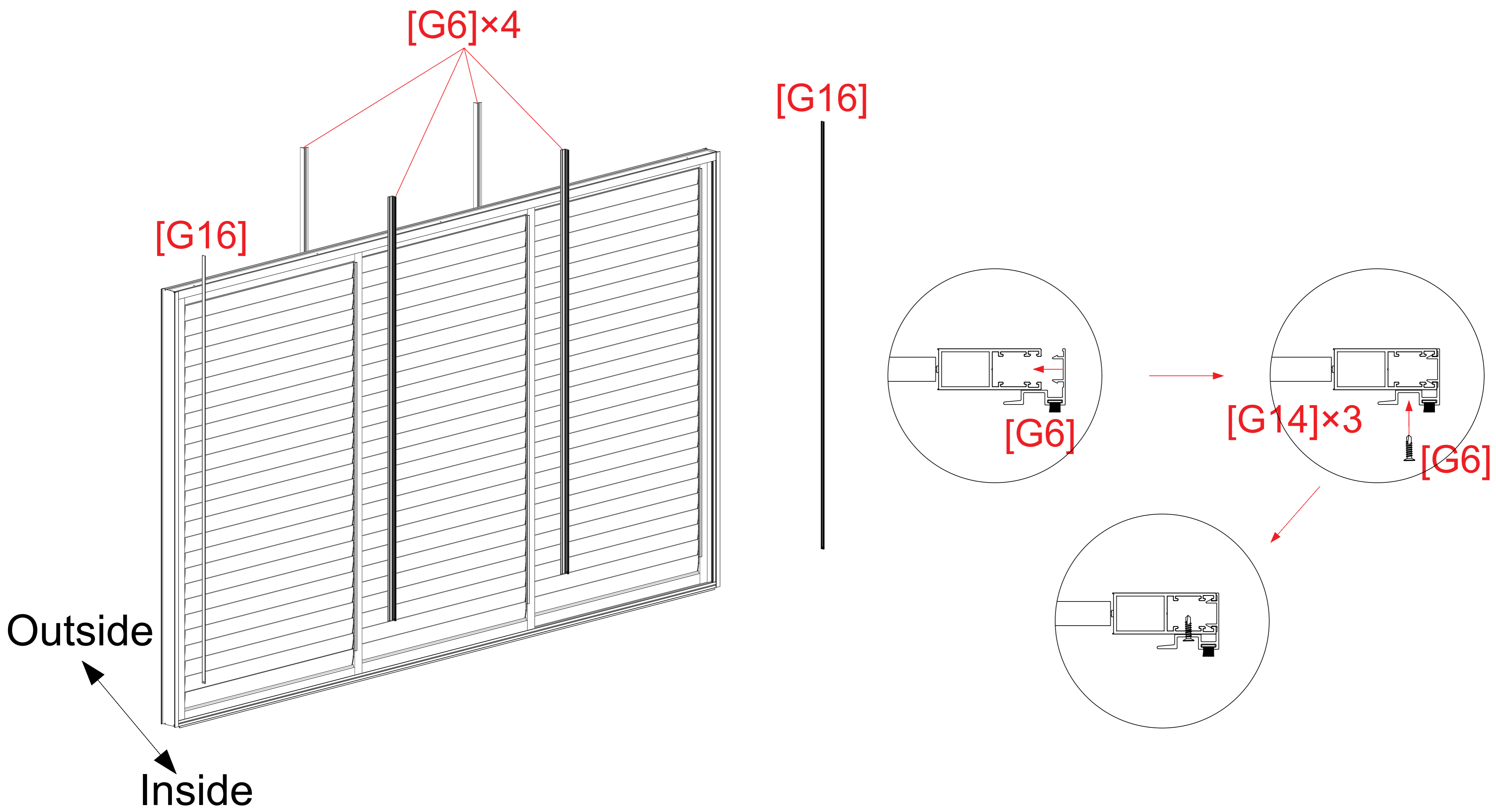
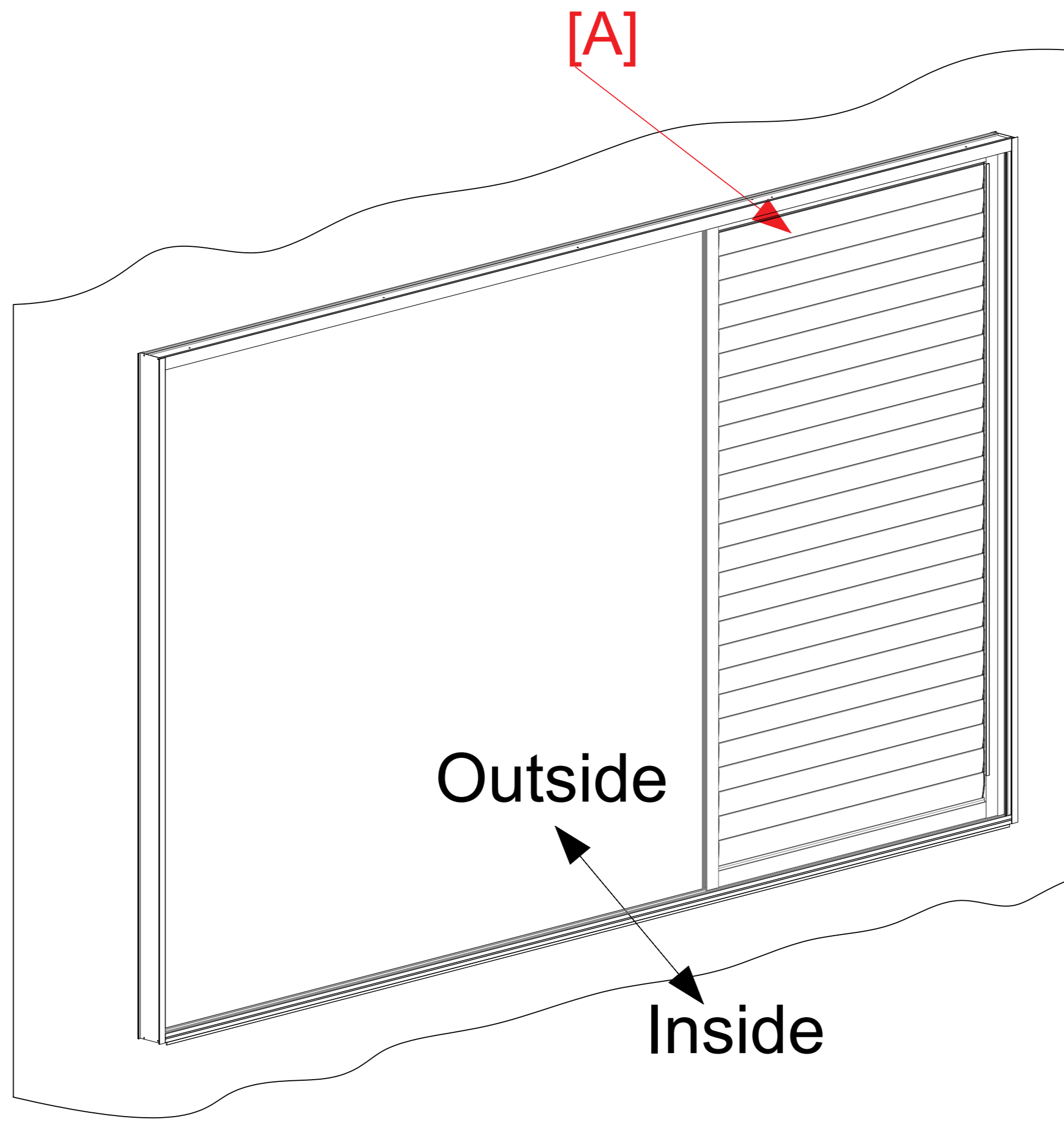
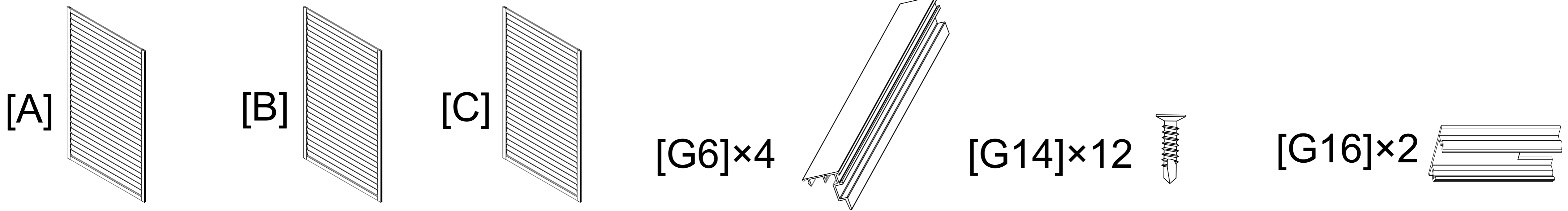

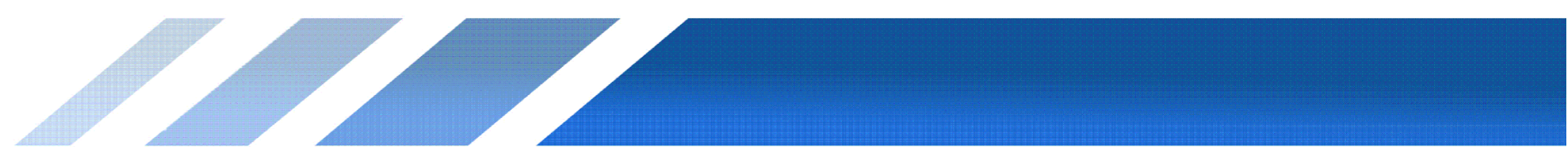
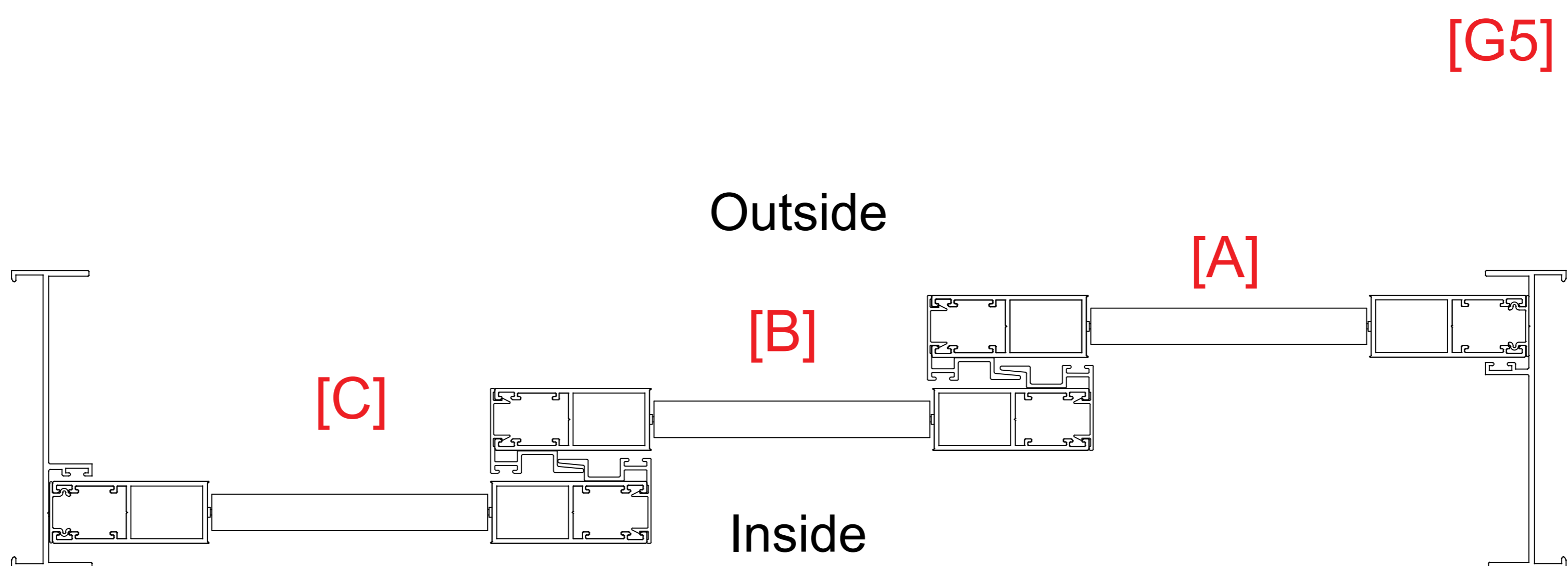
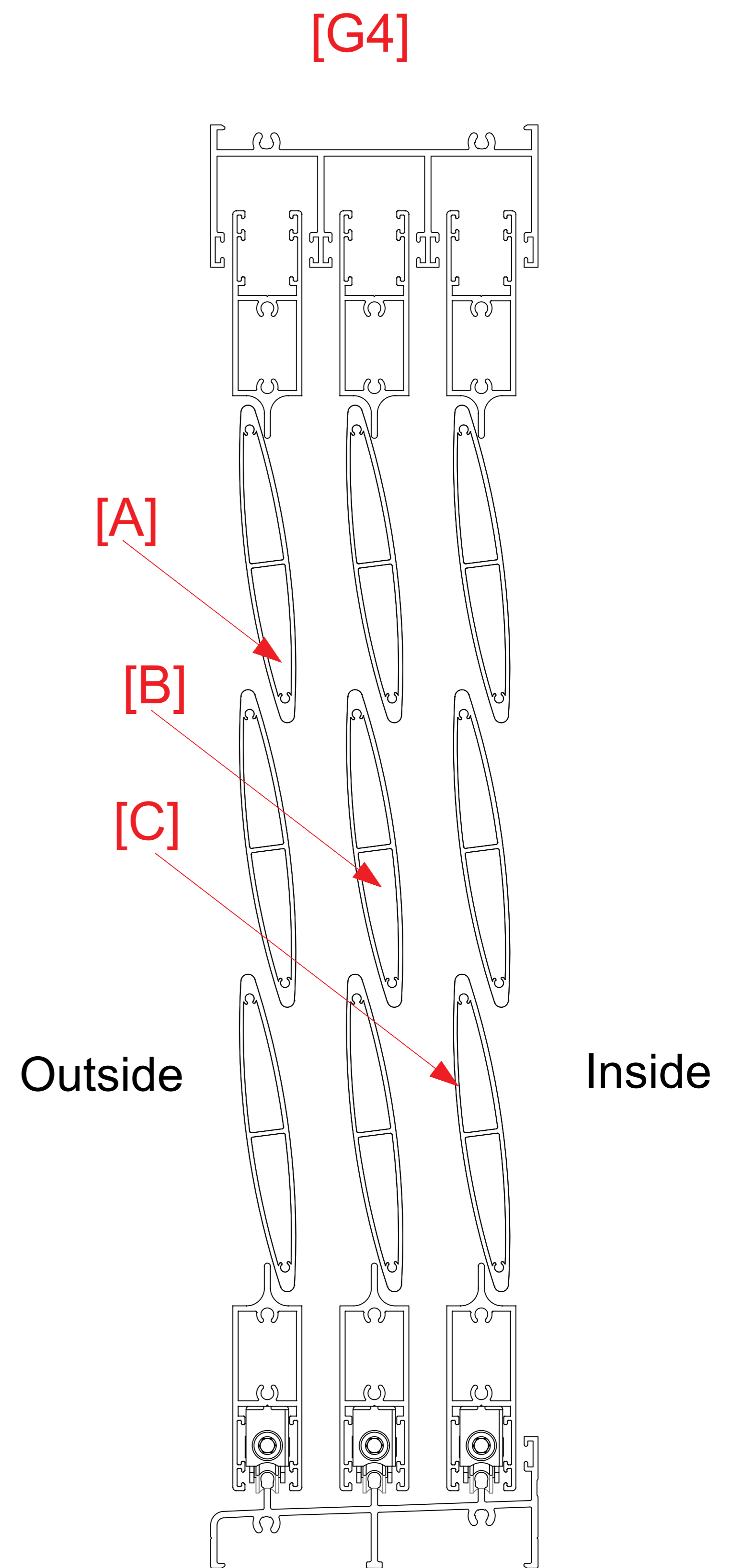
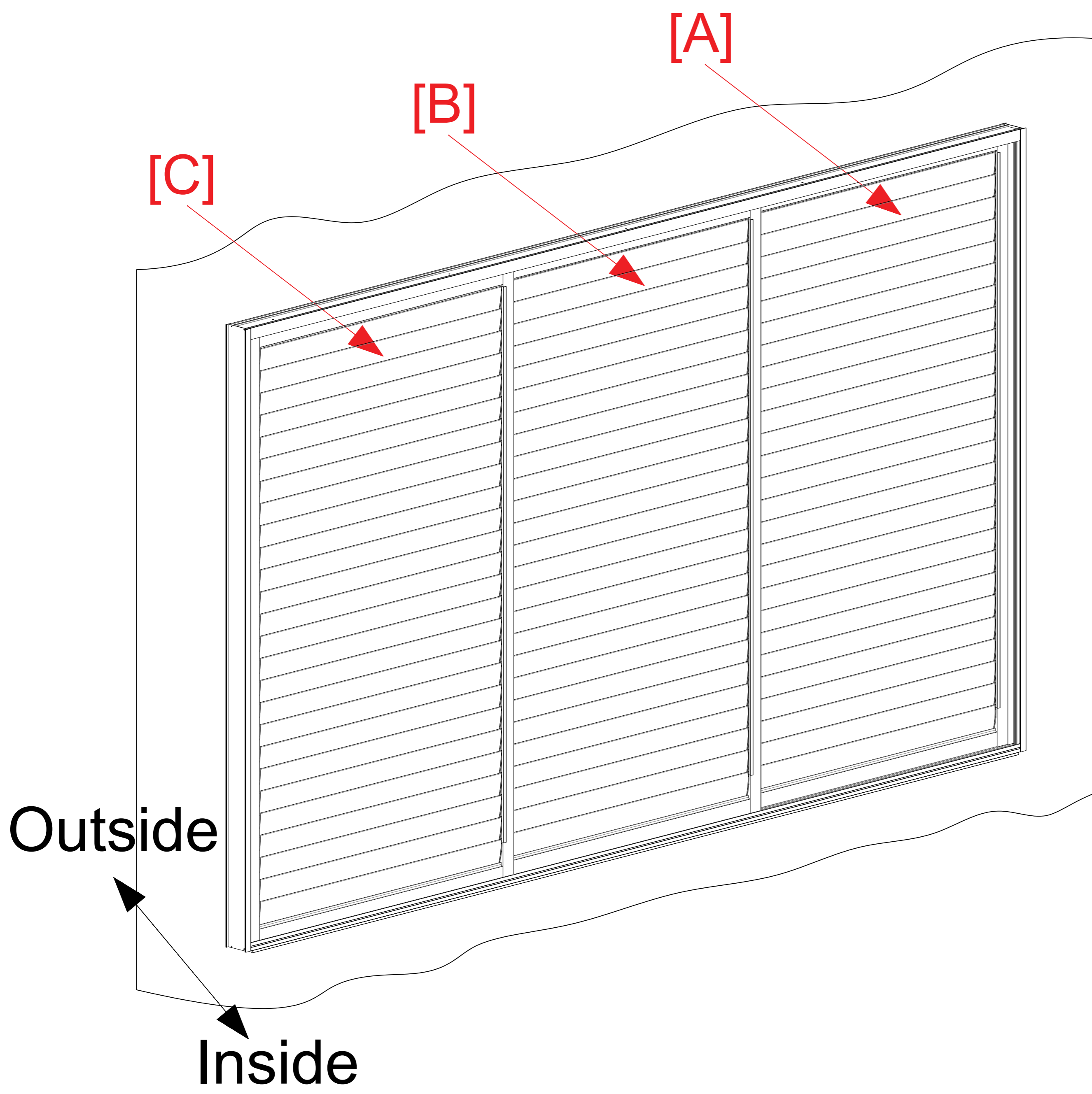

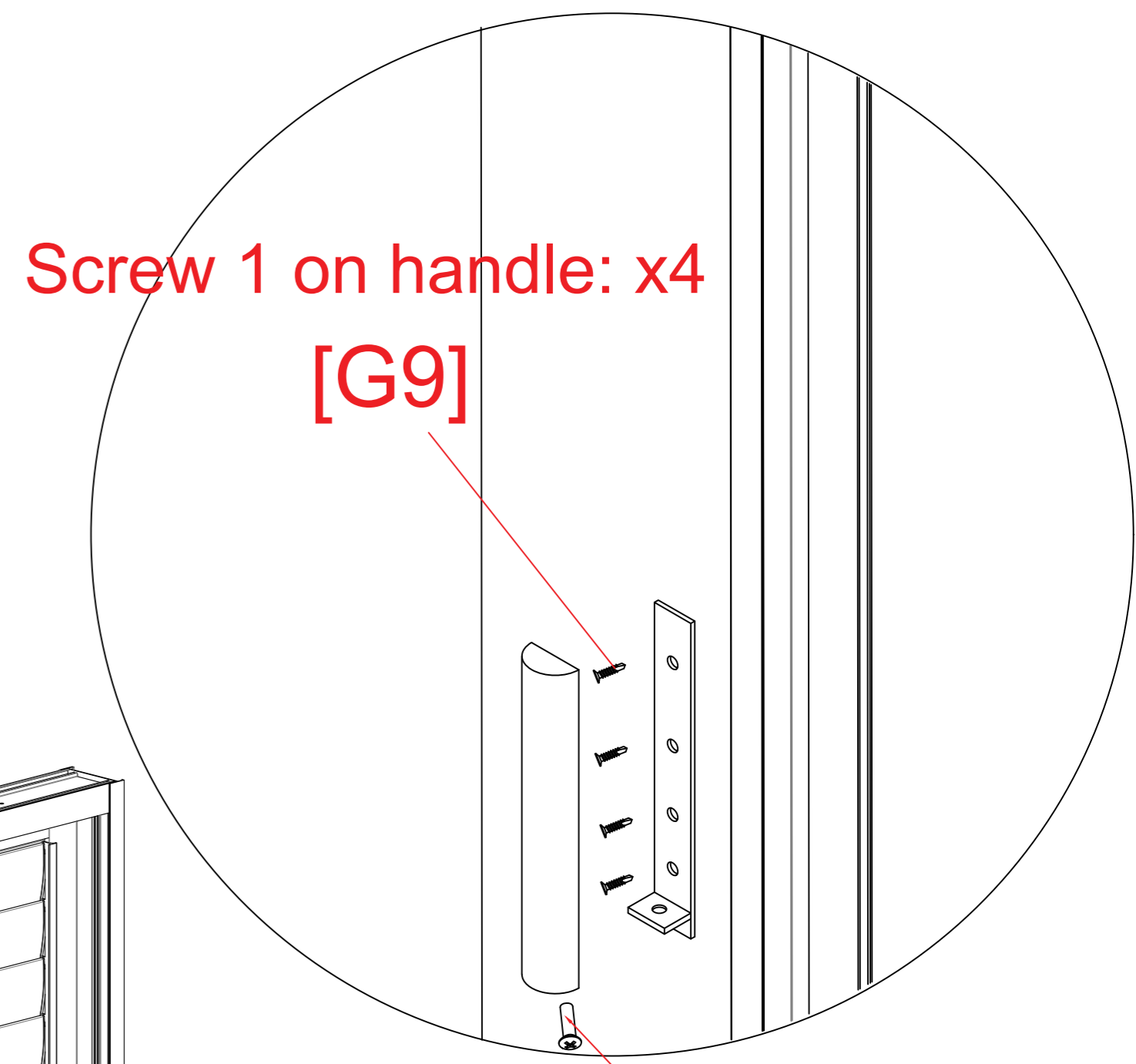
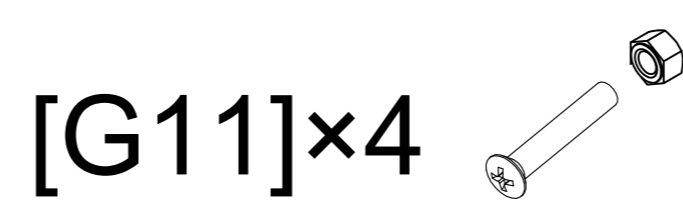
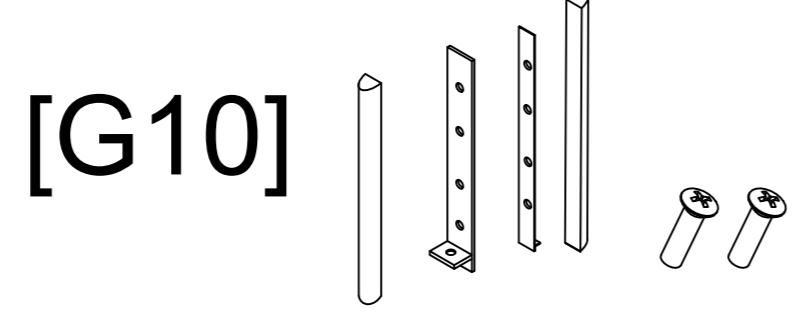
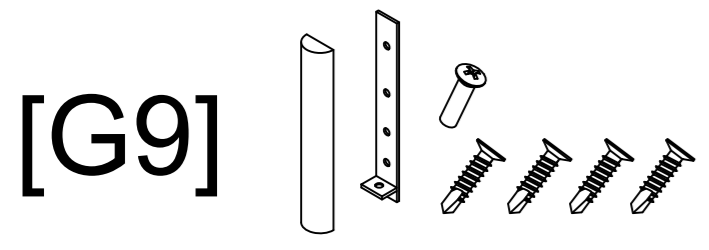

Screw 1 on handle: x4
[G9]

Screw 2 on handle: x1

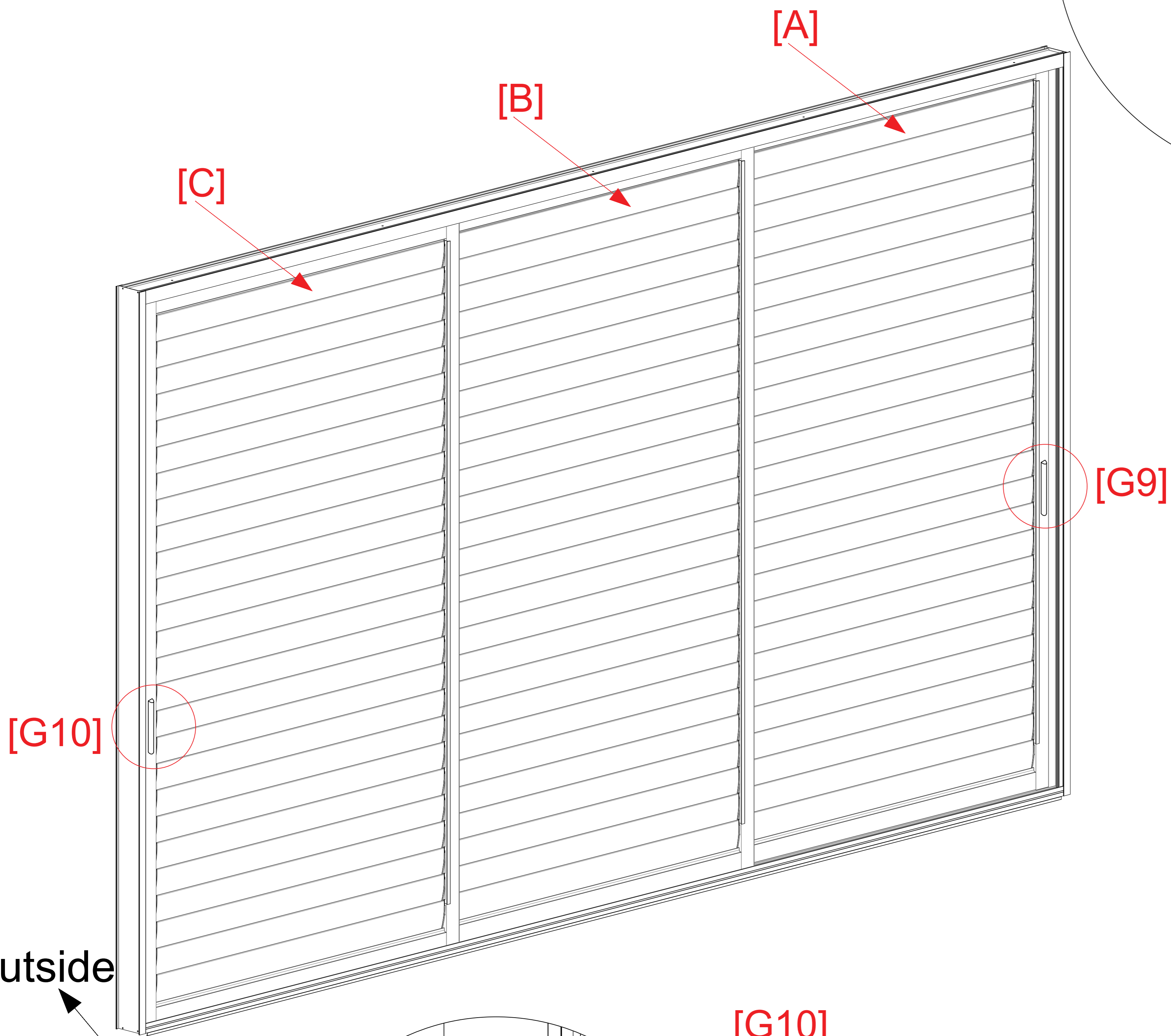

Outside

Inside

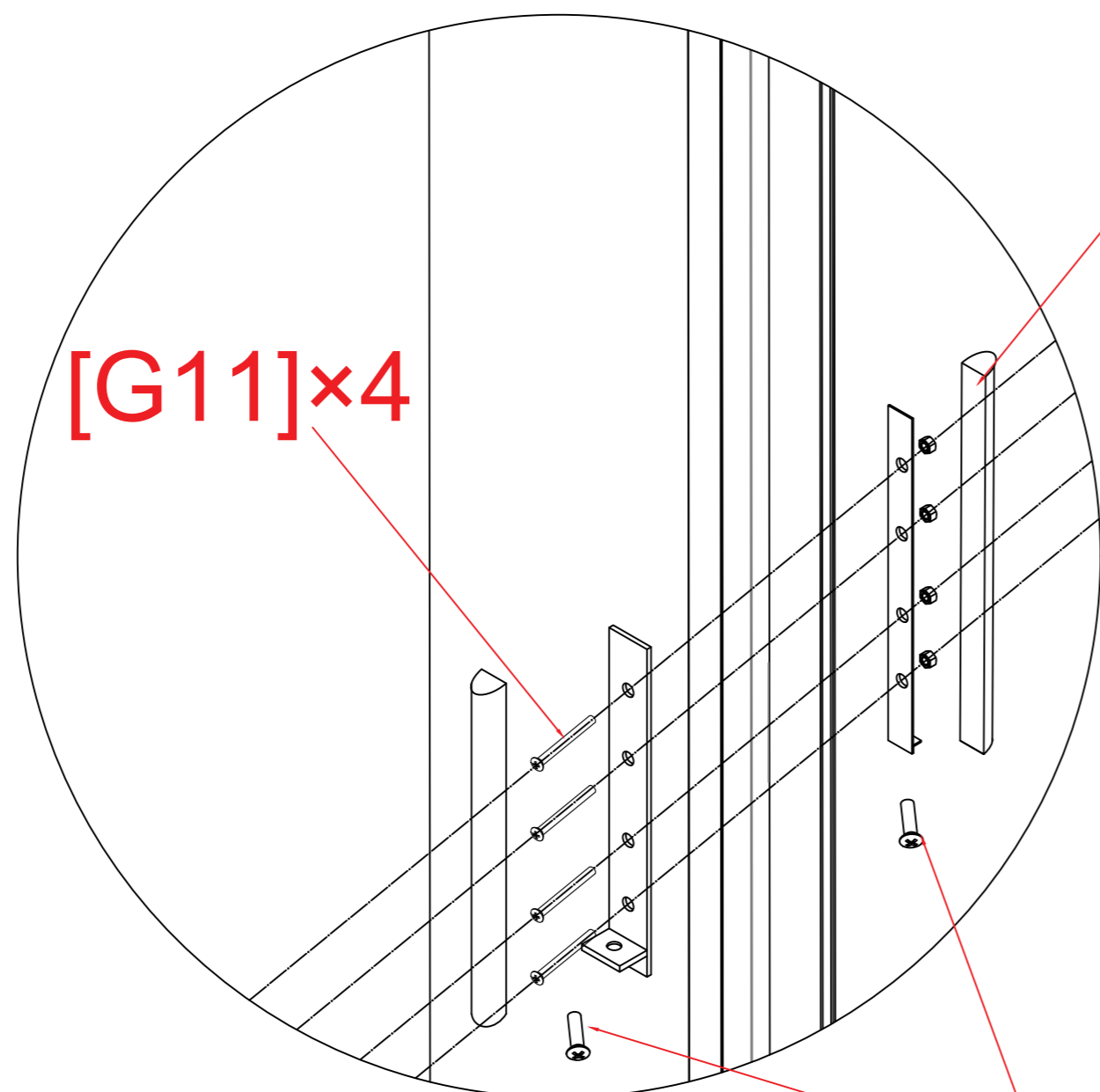

[G11]x4

[G10]

Screw 2 on handle: x2

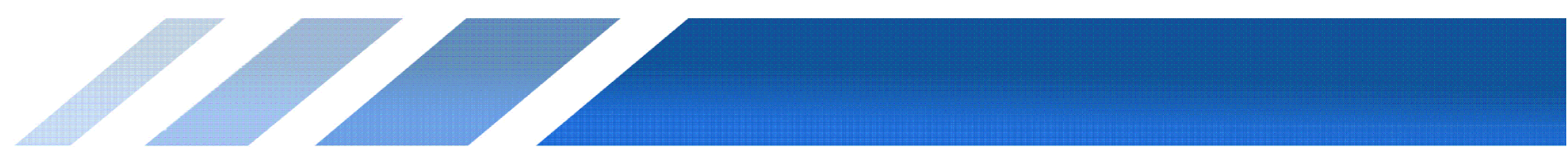



[G15]×2

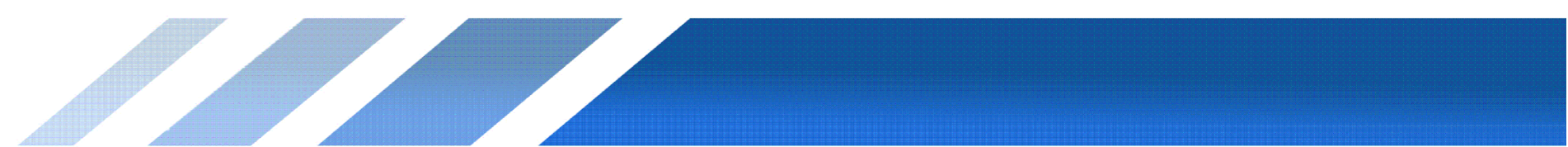
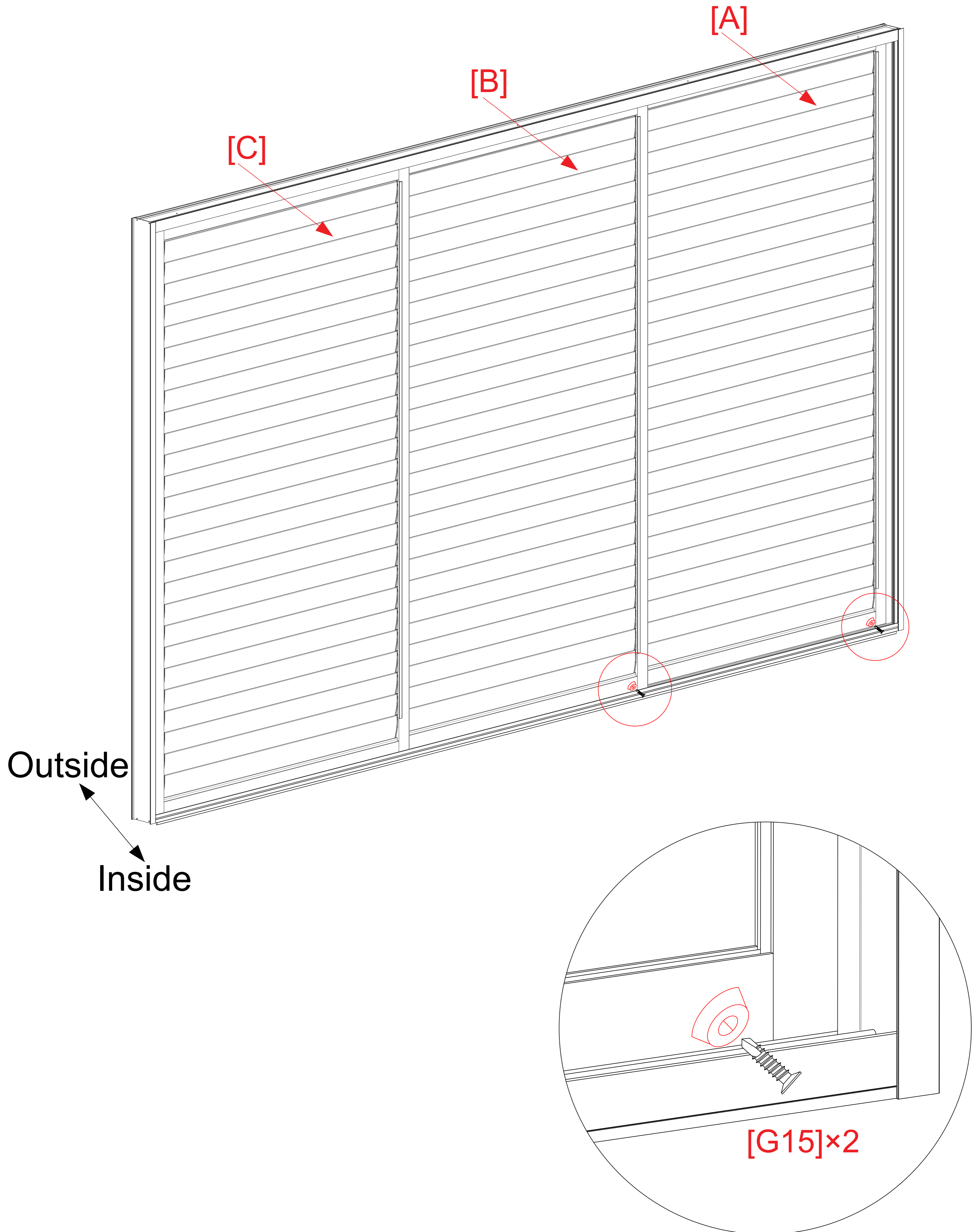
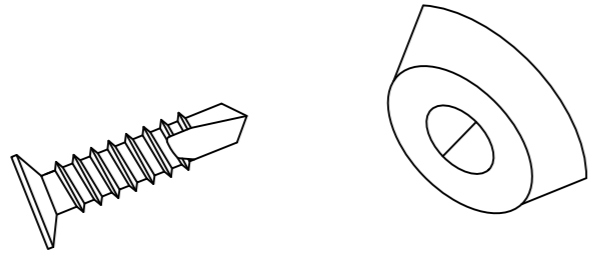

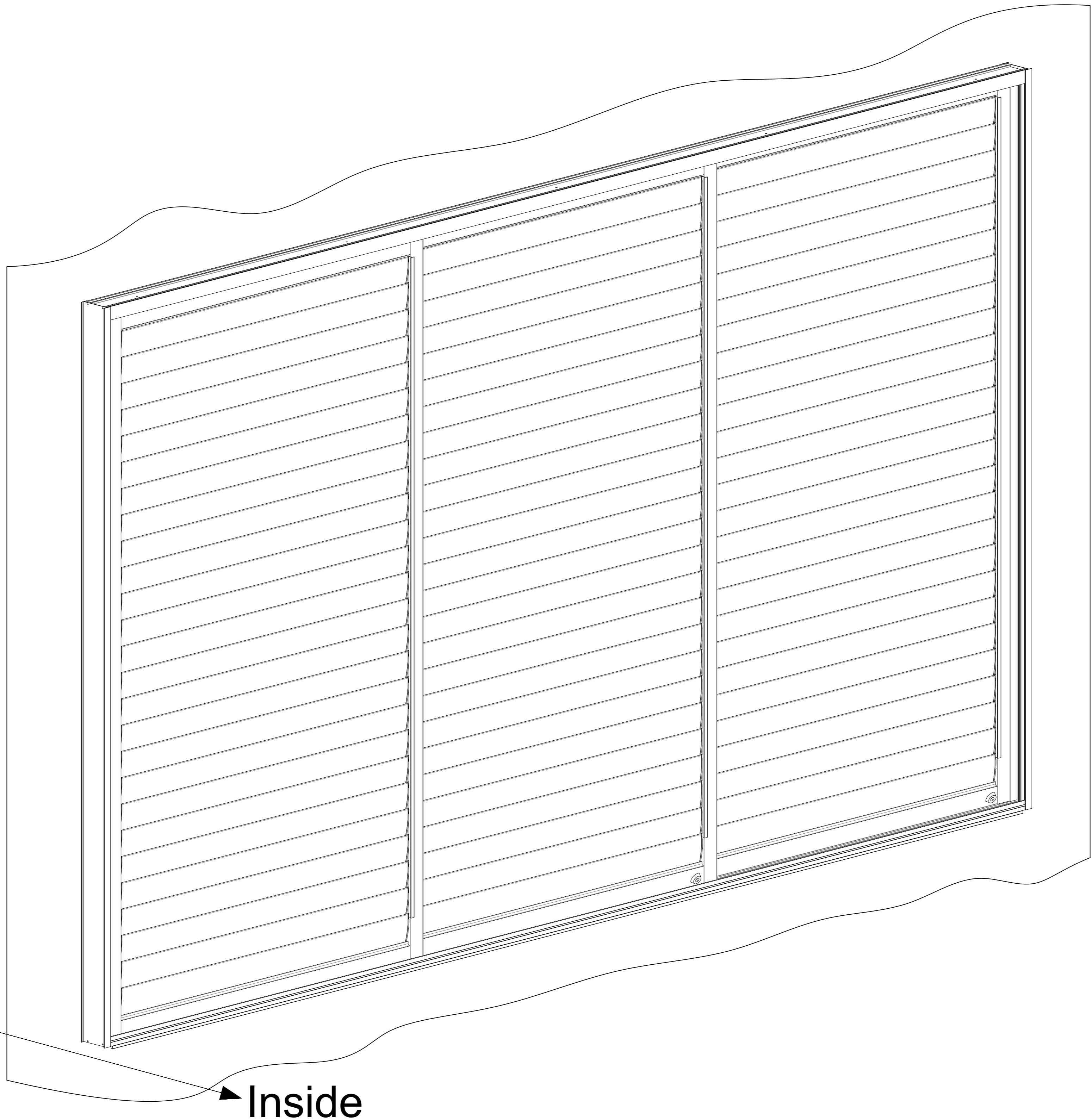

Outside

Inside

