

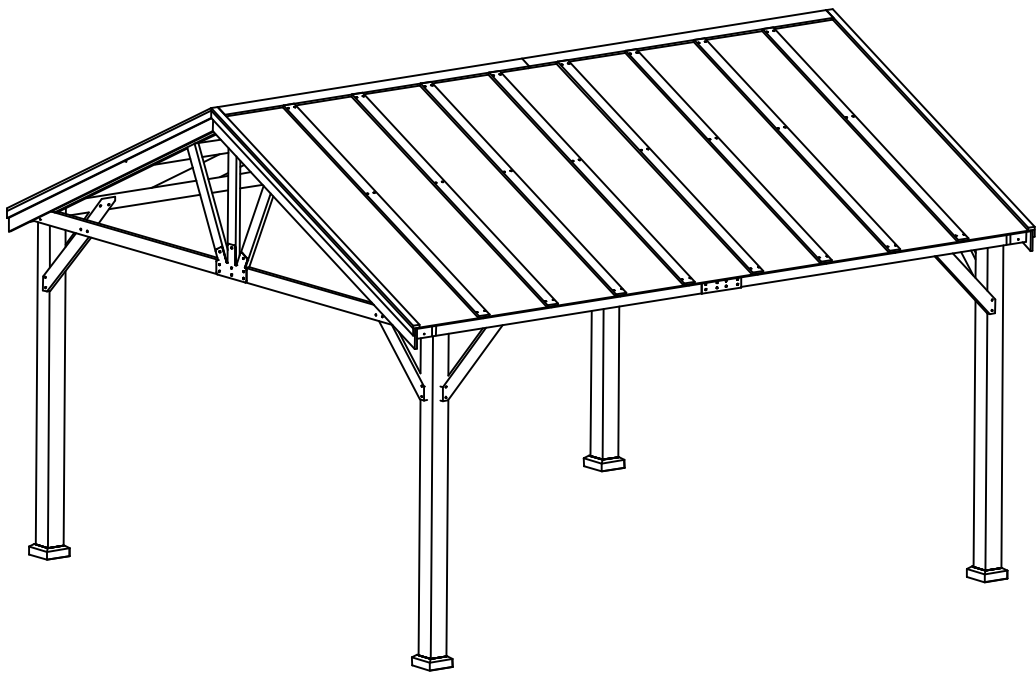

Assembling Instruction

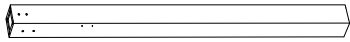

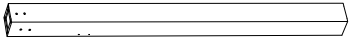



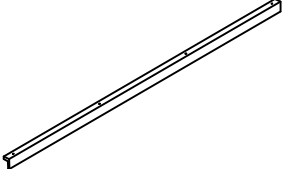
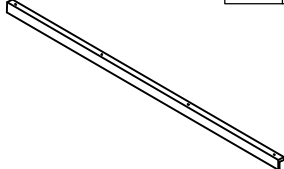

- ATTENTION: 1. Please check the manual carefully and make sure you have received all the parts.
2. If there is any missing, please let us know the letter of the parts you need.
3. If there is any damage, please send clear photos to us, we will check and offer you best solution soon.
4. add the glass glue on the top of roof

Parts List (Box A)

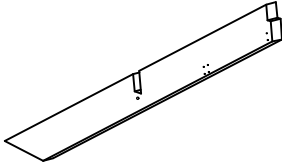
	AA X2		BB X2		LL X16
	NN X2		OO X2		

Parts List (Box B)

	EE X4		FF X2		GG X2
	HH X2		II X2		JJ X2

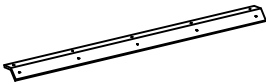
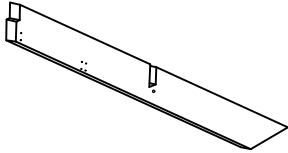
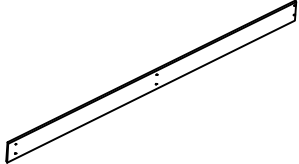
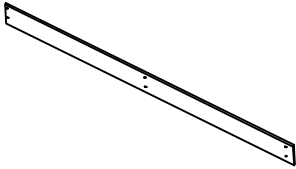

Parts List (Box C)

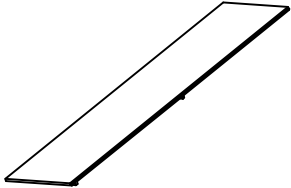
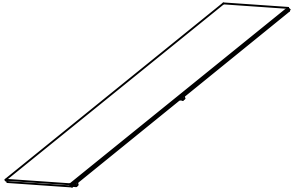
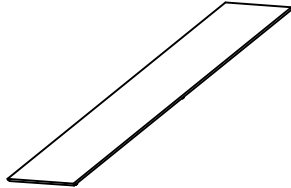



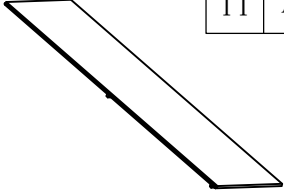
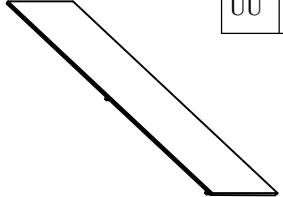
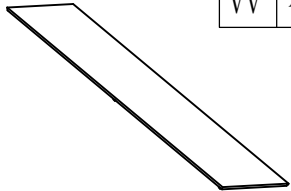









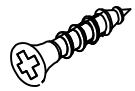
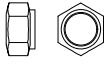

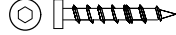
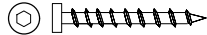
		
--	--	--

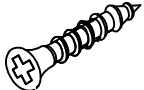
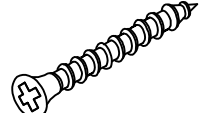

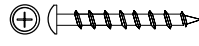
Parts List (Box D)

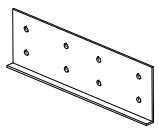
		
---	---	---

Parts List (Box E)

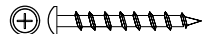
		
---	---	---

CC		X4		DD		X4	
							
A		x16+(1)		B		x58+(1)	
M8*165mm				M8*45mm			
							
C		x16+(1)		D		x48+(2)	
M8*55mm				M4*20mm			
							
E		x90+(2)		F		x82+(2)	
M8				ø20*1.4mm			
							
G		x16+(1)		H		x32+(1)	
M6*40mm				M6*55mm			
							
I		x1		J		x16+(1)	
M6				M5*30mm			
							
K		x6+(1)		L		x100+(2)	
M5*80mm				M4*25mm			
							
M		x36+(2)		N		x4	
M4*50mm				173*173mm			
							
O		x4		P		x10	
160*160mm				300*93mm			
							
Q		x2		R		x8	
M8				ø8*180			
							
S		x4		T		x64+(2)	
M6*89mm				M4*60mm			
							

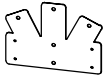
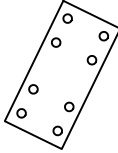
<table border="1"> <tr> <td>U</td> <td>x4</td> </tr> <tr> <td colspan="2">M6*65mm</td> </tr> </table> 	U	x4	M6*65mm		<table border="1"> <tr> <td>V</td> <td>x12</td> </tr> <tr> <td colspan="2">ø8*30</td> </tr> </table> 	V	x12	ø8*30		<table border="1"> <tr> <td>W</td> <td>x3</td> </tr> <tr> <td colspan="2">200*100mm</td> </tr> </table>  <p>asphalt tile</p>	W	x3	200*100mm		<table border="1"> <tr> <td>X</td> <td>x2</td> </tr> <tr> <td colspan="2">300*230mm</td> </tr> </table> 	X	x2	300*230mm	
U	x4																		
M6*65mm																			
V	x12																		
ø8*30																			
W	x3																		
200*100mm																			
X	x2																		
300*230mm																			
<table border="1"> <tr> <td>Y</td> <td>x6</td> </tr> <tr> <td colspan="2">80*38mm</td> </tr> </table> 	Y	x6	80*38mm																
Y	x6																		
80*38mm																			

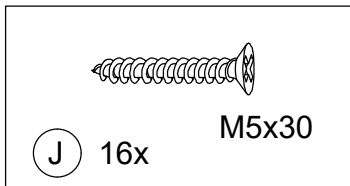
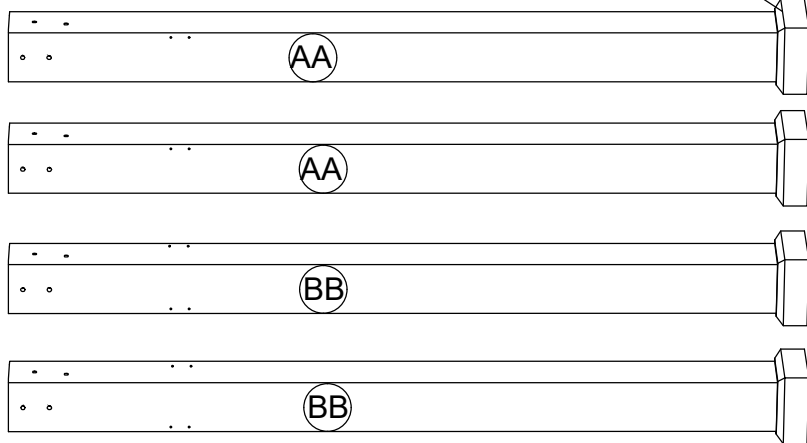
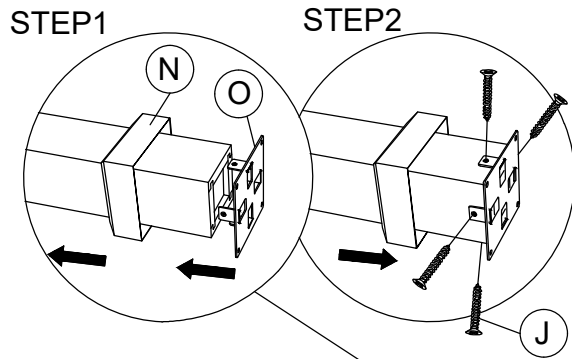
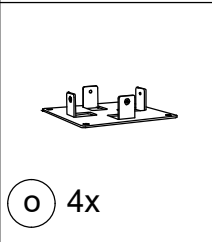
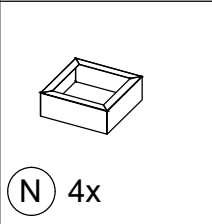
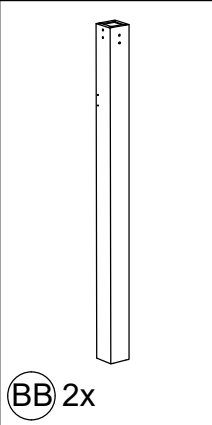
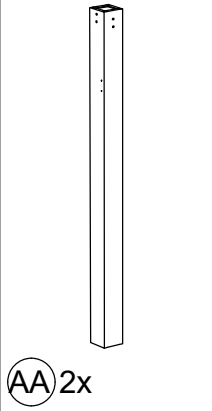

Step1

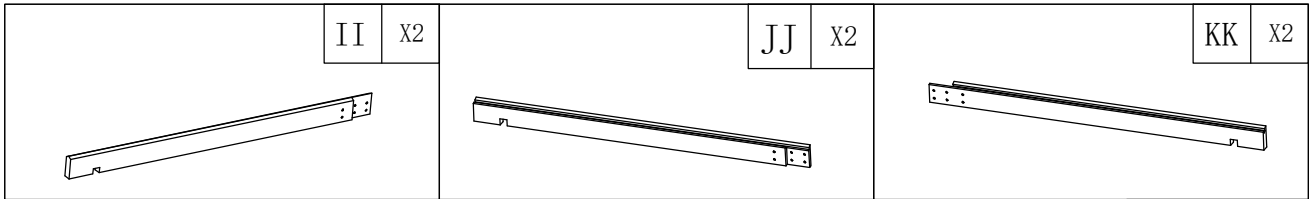



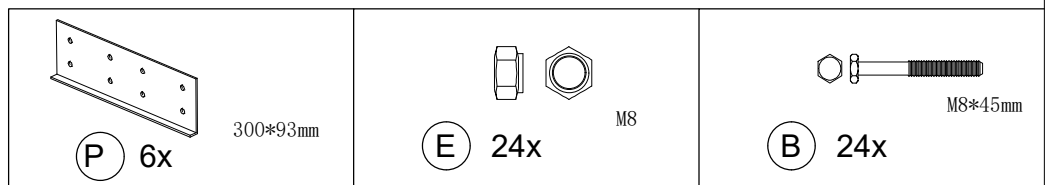
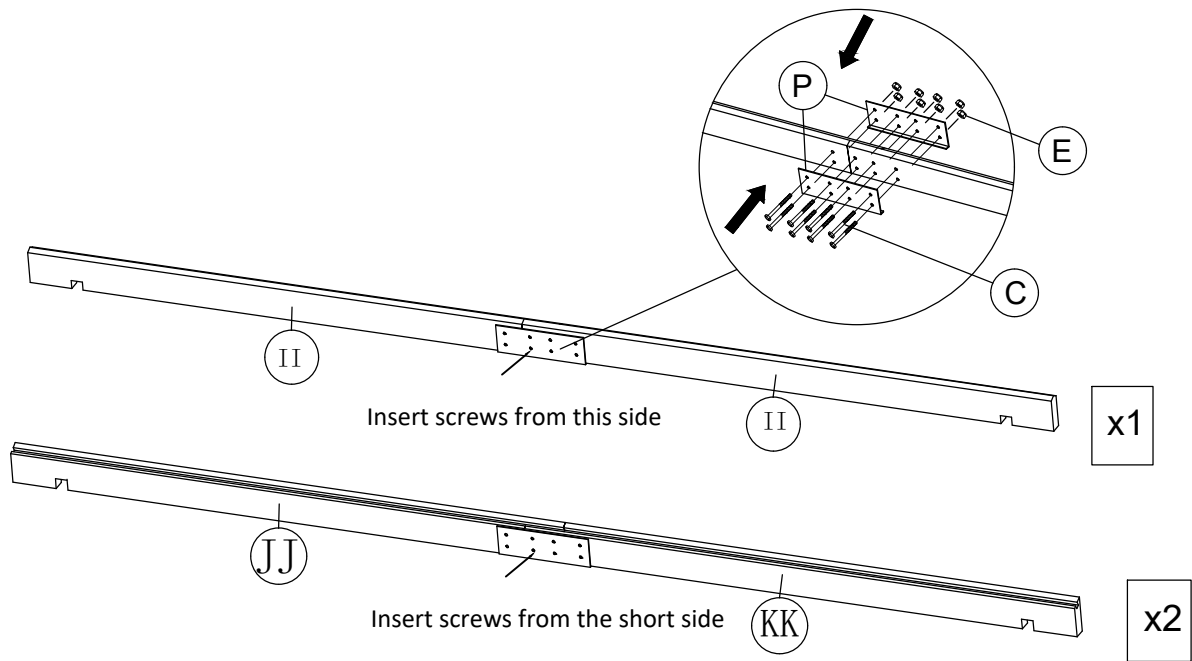

Step2



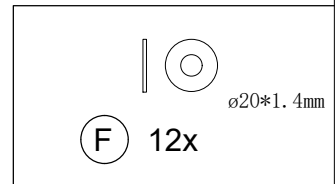
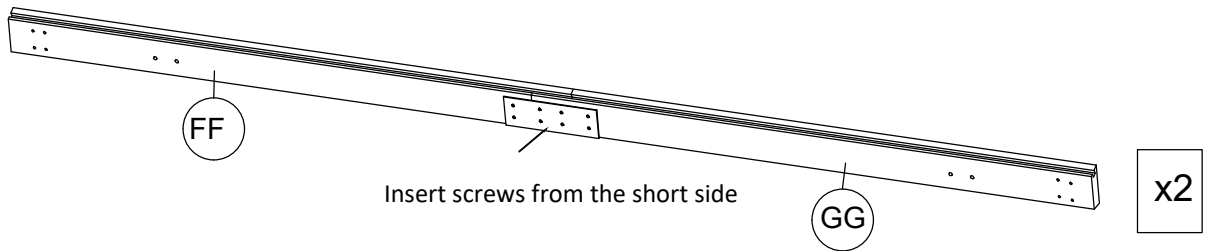
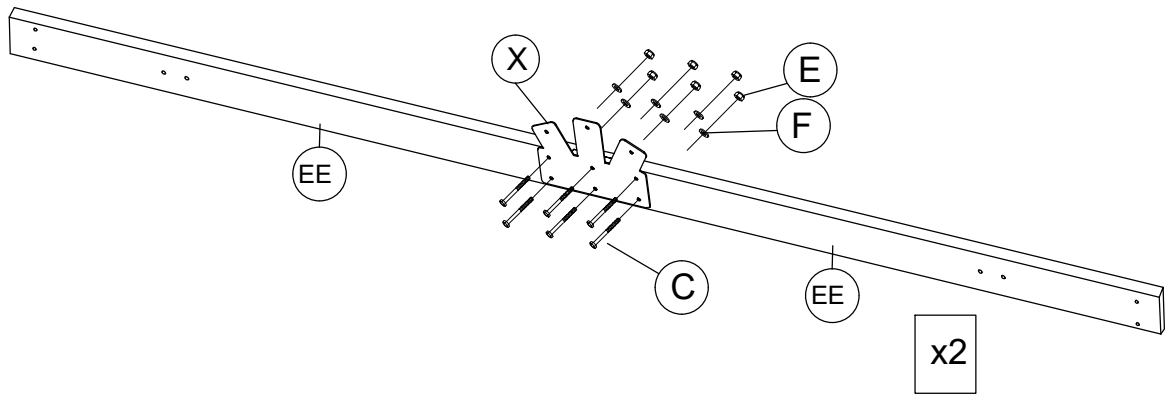

<table border="1"> <tr> <td>EE</td> <td>X4</td> </tr> </table> 	EE	X4	<table border="1"> <tr> <td>FF</td> <td>X2</td> </tr> </table> 	FF	X2	<table border="1"> <tr> <td>GG</td> <td>X2</td> </tr> </table> 	GG	X2
EE	X4							
FF	X2							
GG	X2							

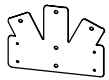
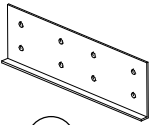
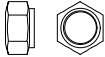
Step3

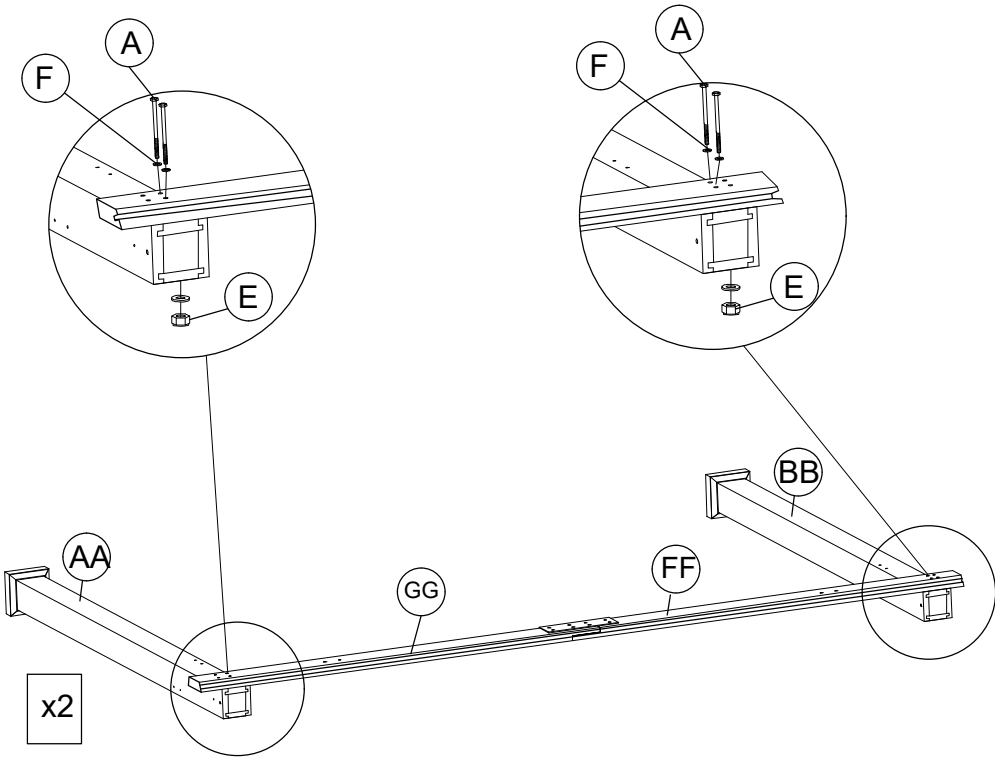

 <p>300*230mm</p> <p>(X) 2x</p>	 <p>300*93mm</p> <p>(P) 4x</p>	 <p>M8</p> <p>(E) 28x</p>	 <p>M8*45mm</p> <p>(B) 28x</p>
--	---	---	---

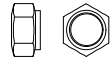

 (A) 8x M8*165mm	 (F) 16x $\phi 20 \times 1.4\text{mm}$	 (E) 8x M8
---	--	---

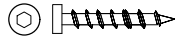
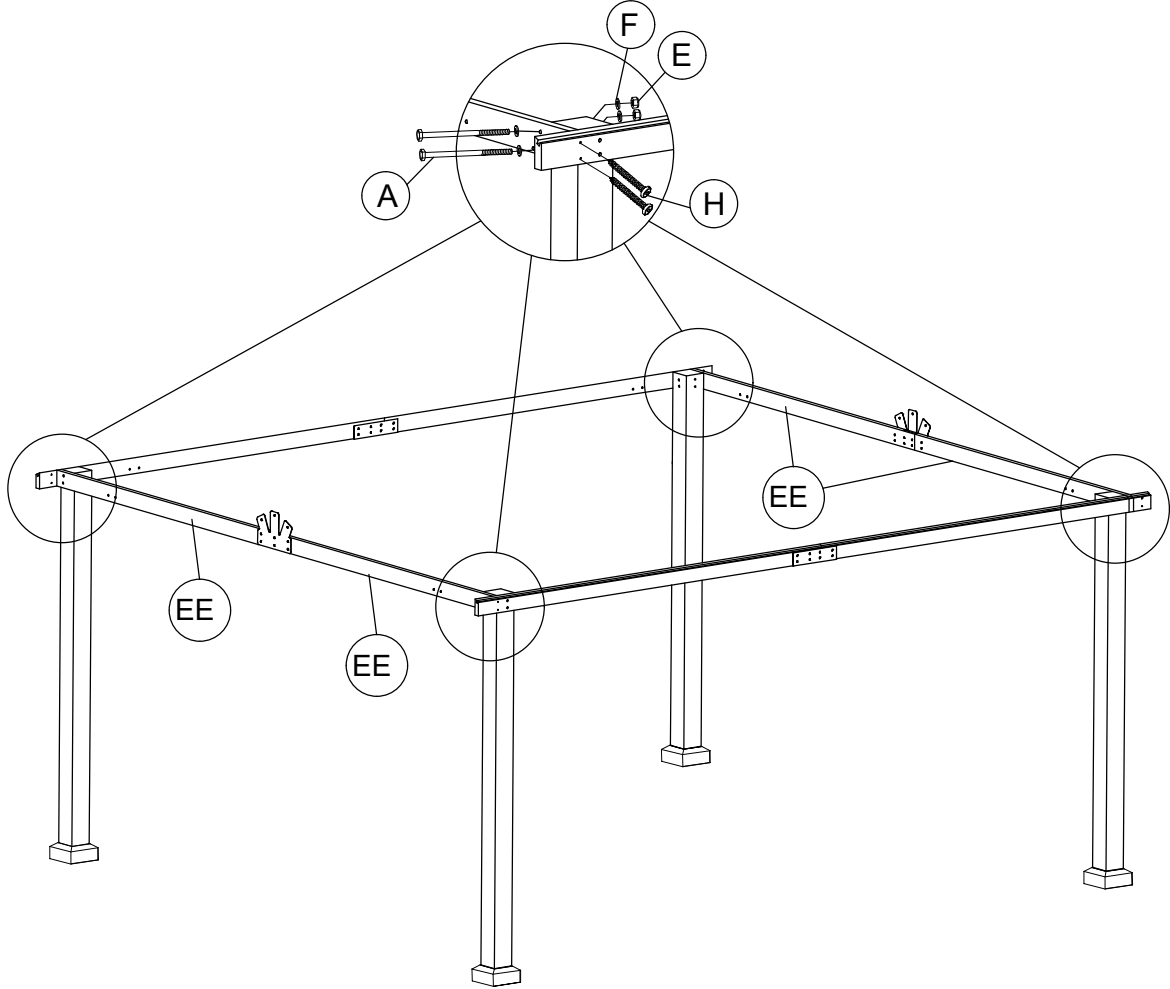

M6*55mm

(H) 8x



M8*165mm

(A) 8x



ø20*1.4mm

(F) 16x

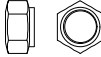

M8

(E) 8x

CC X4

DD X4

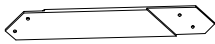

Step6

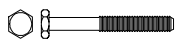
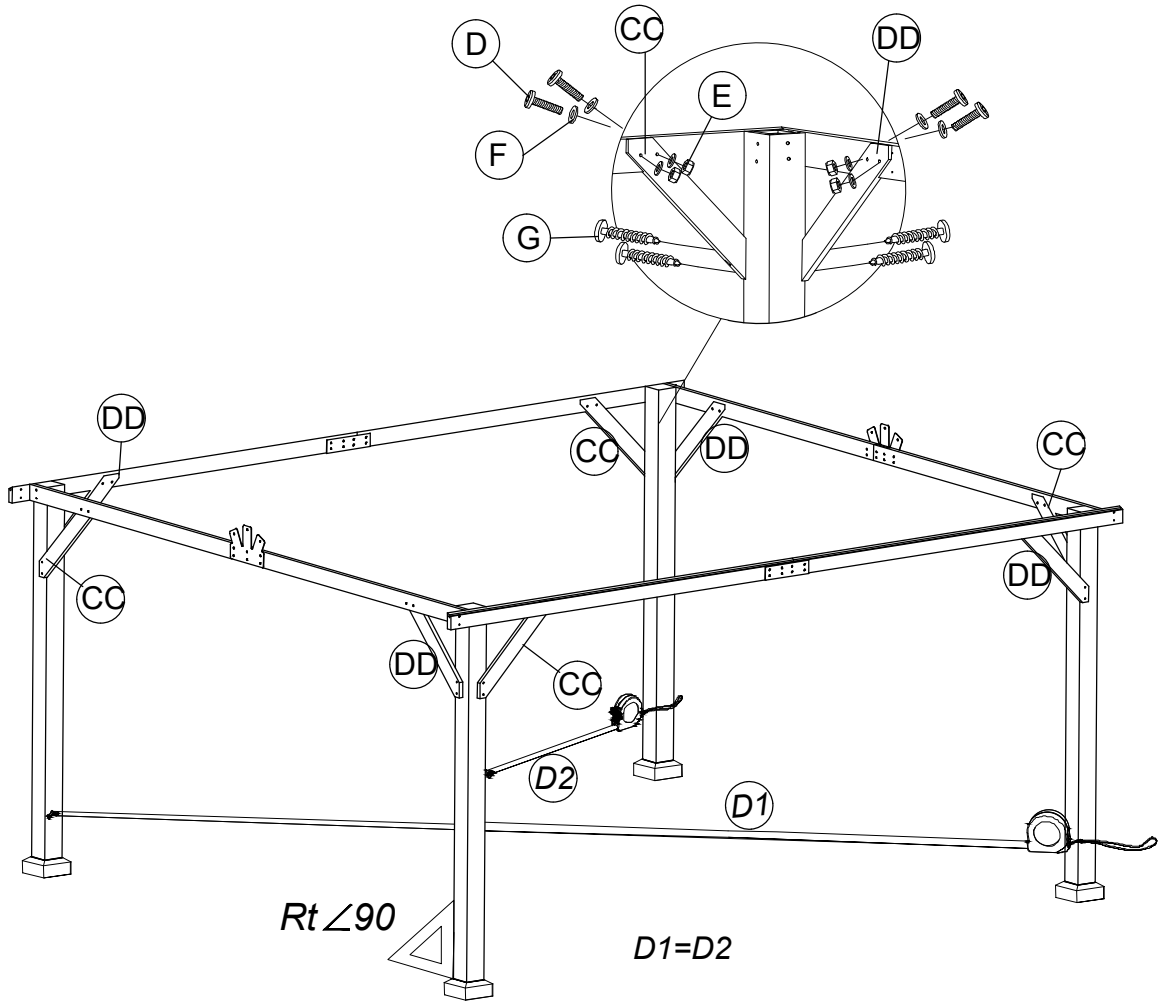

M8*55mm

(C) 16x



$\phi 20 \times 1.4 \text{mm}$

(F) 32x

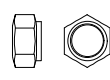

M8

(E) 16x

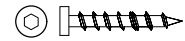

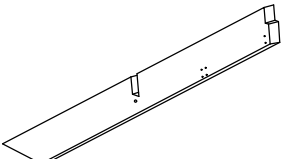
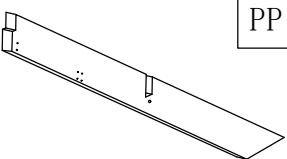
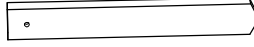
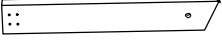
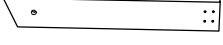

M6*40mm

(G) 16x

	HH	x2		PP	x2		WW	x2
	XX	x2		YY	x2			

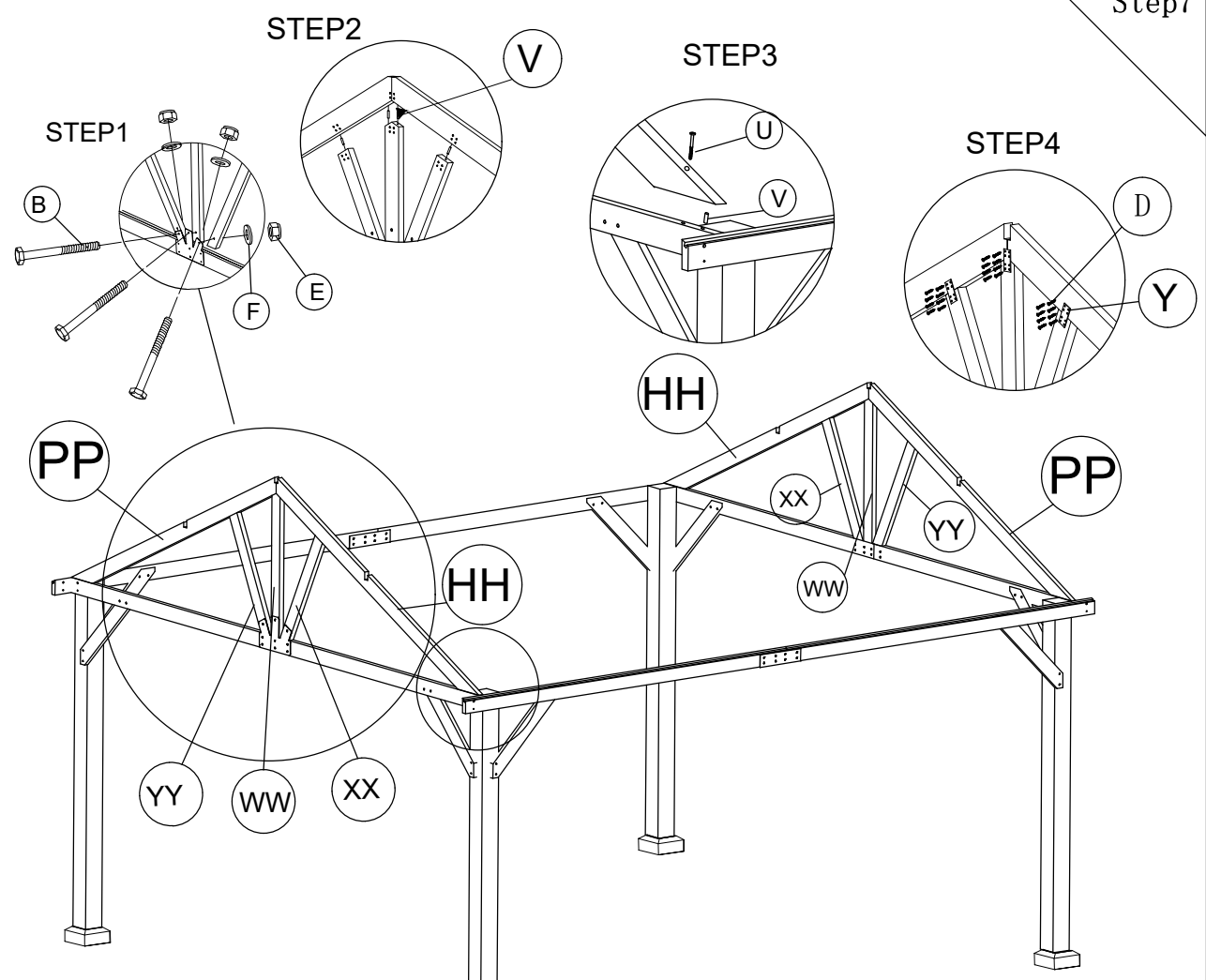
Step7

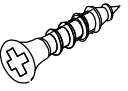
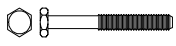
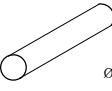
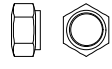
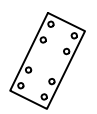
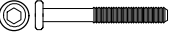

	80*38mm	Y	6x		M6*65mm	U	4x		ø8*30	V	12x
	M4*20mm	D	48x		M8*45mm	B	6x		ø20*1.4mm	F	6x
									M8	E	6x

Step8

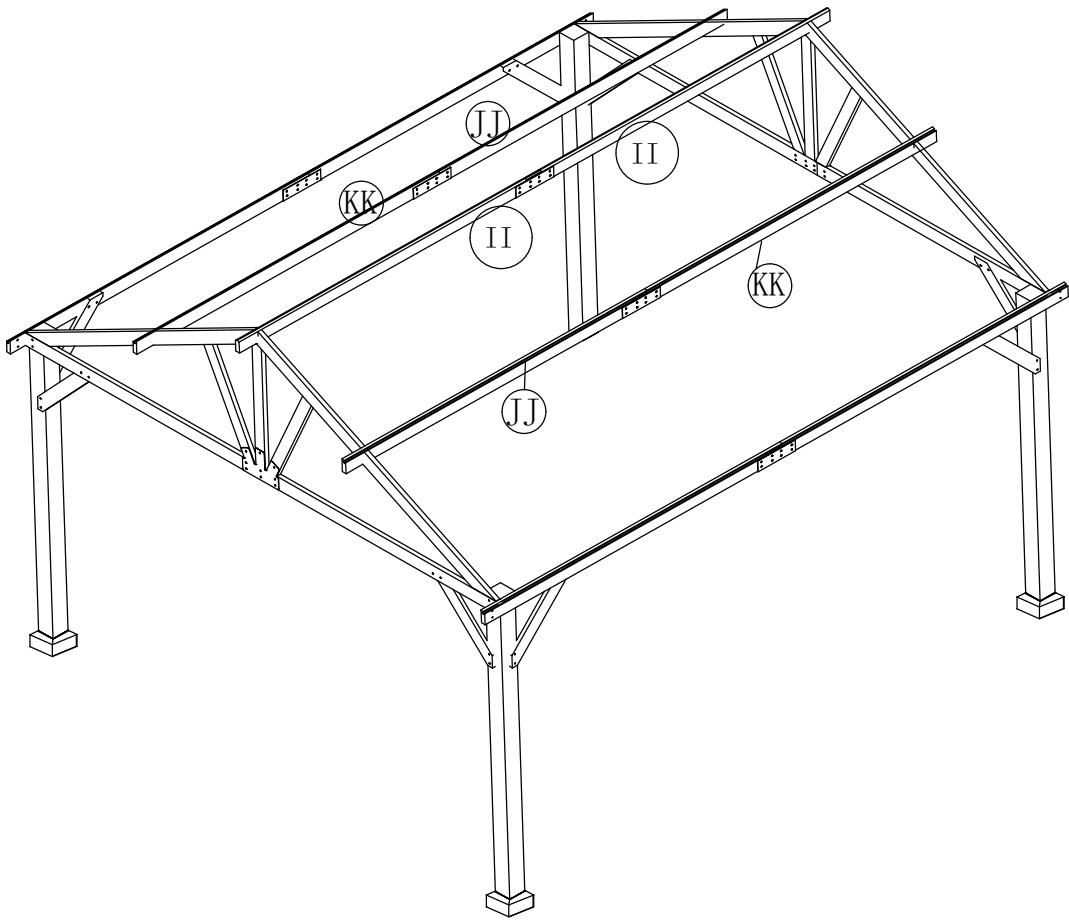

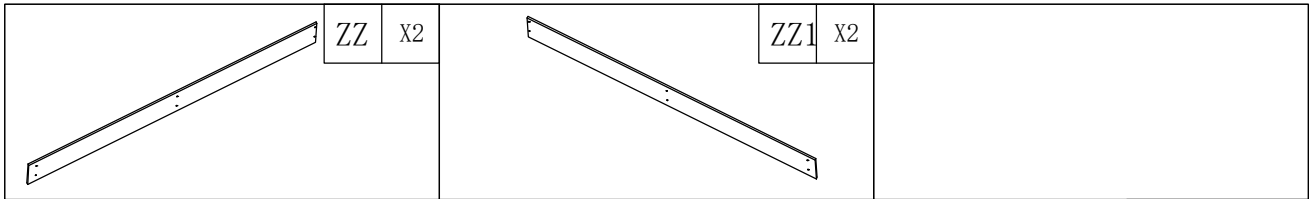

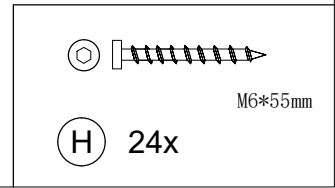
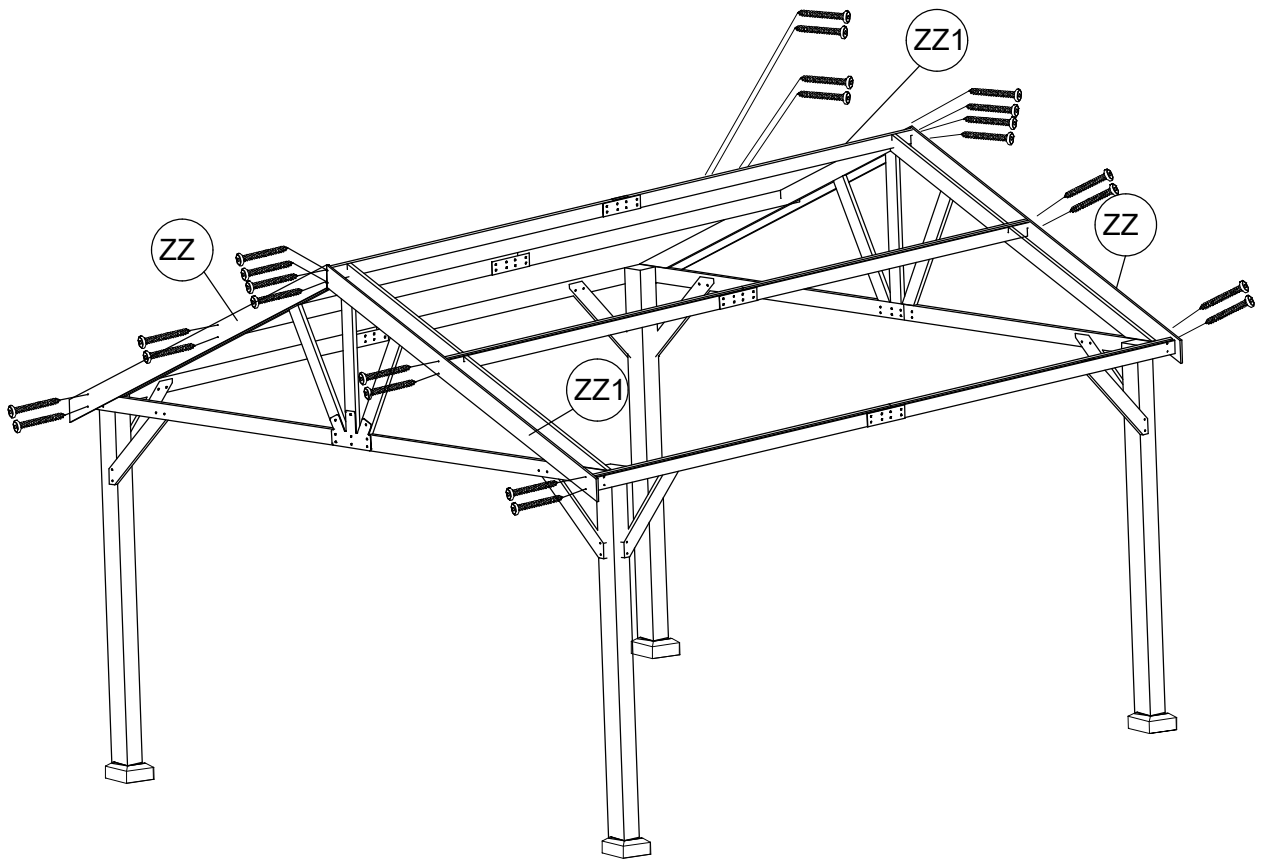

Step9

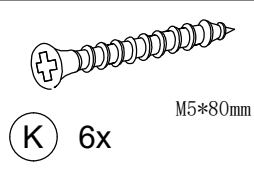
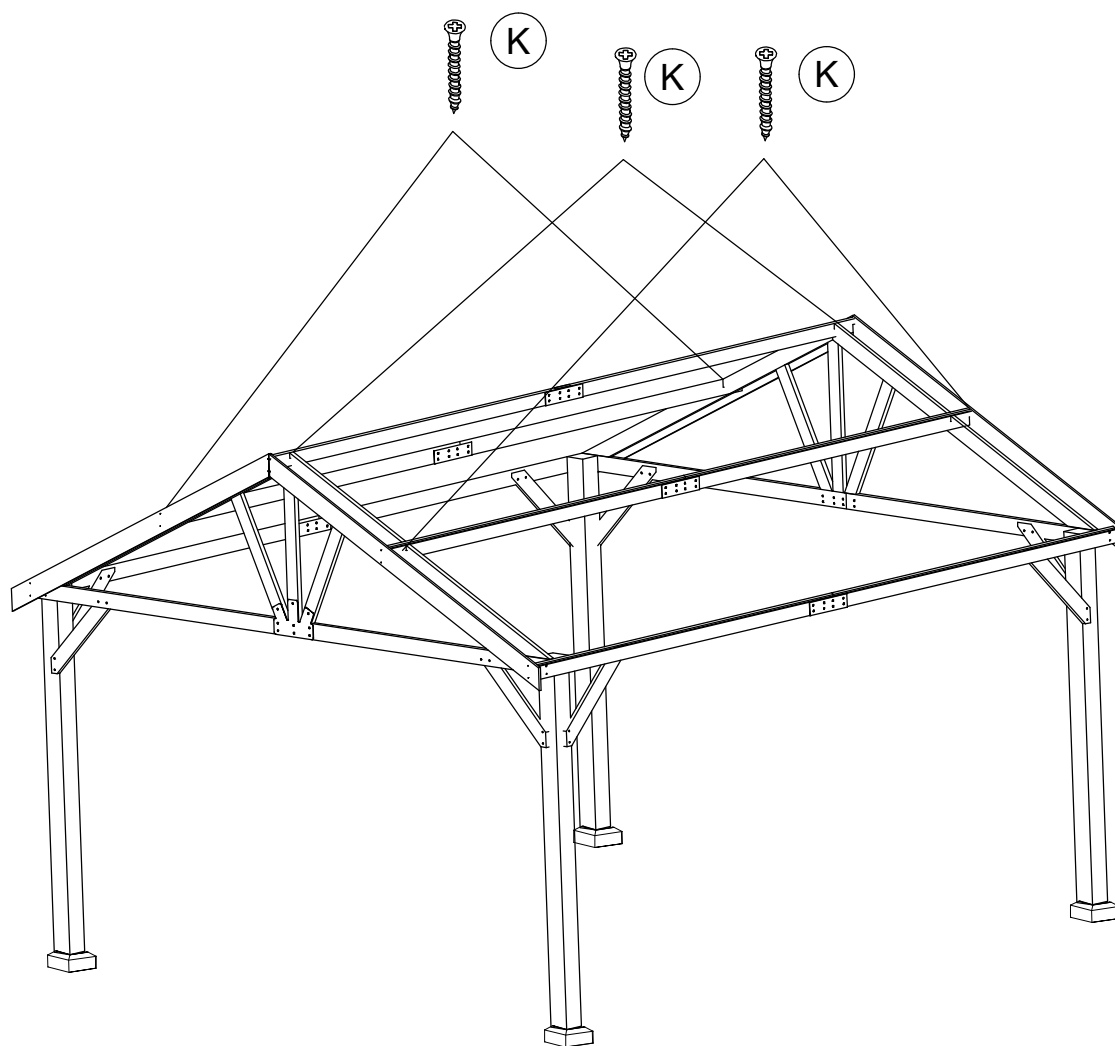

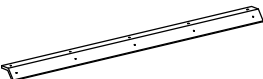

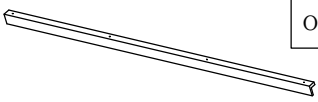
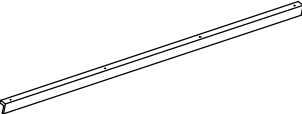
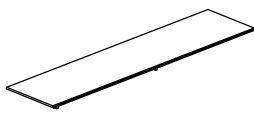
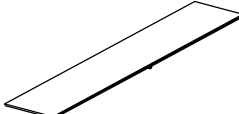
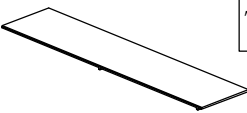
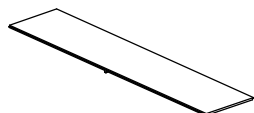
	MM X1		LL X10		OO X1
	NN X1		QQ X1		RR X5
	TT X1		UU X5	Step11	

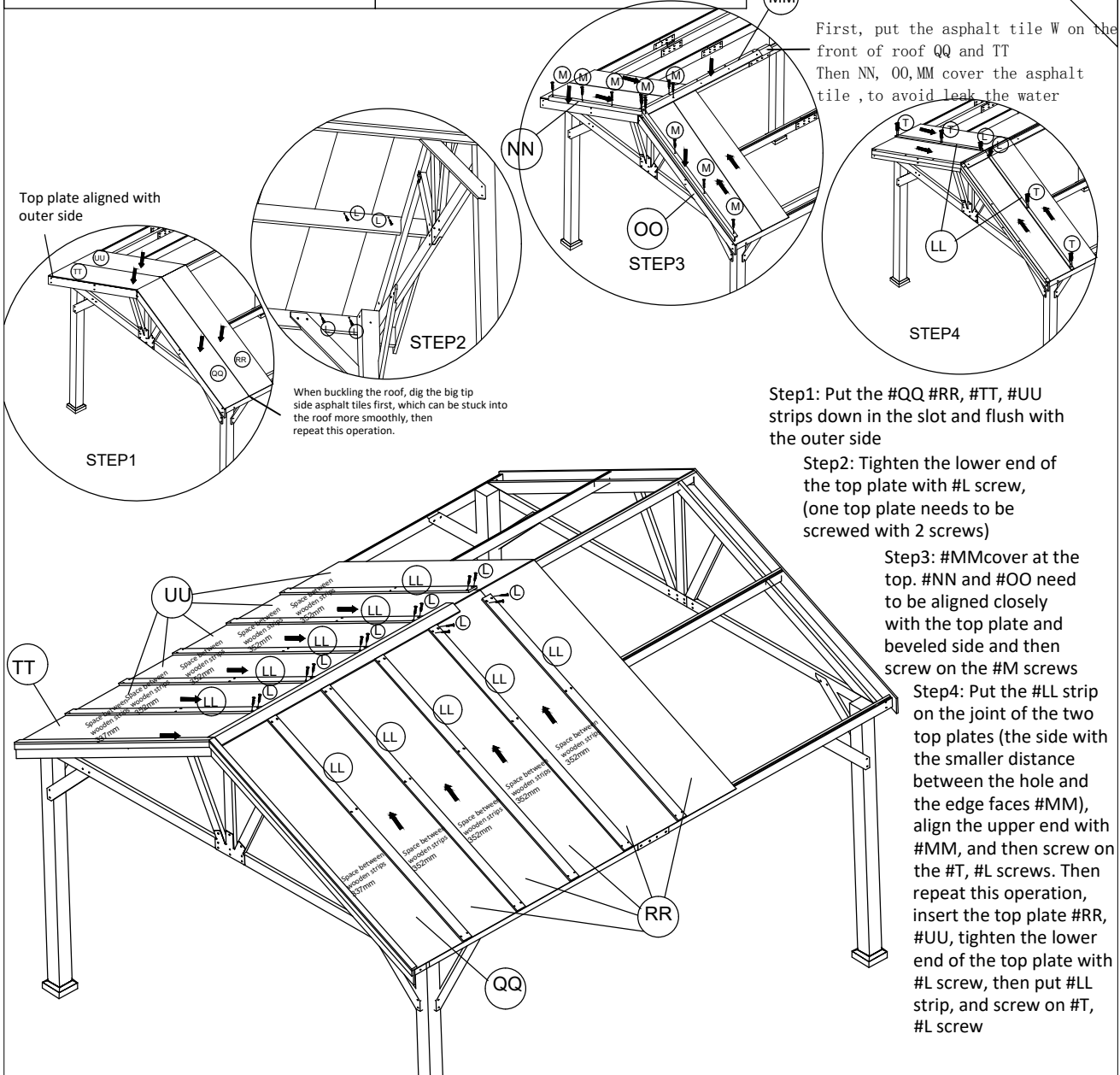

First, put the asphalt tile W on the front of roof QQ and TT. Then NN, OO, MM cover the asphalt tile, to avoid leak the water.

Top plate aligned with outer side



When buckling the roof, dig the big tip side asphalt tiles first, which can be stuck into the roof more smoothly, then repeat this operation.



Step1: Put the #QQ #RR, #TT, #UU strips down in the slot and flush with the outer side

Step2: Tighten the lower end of the top plate with #L screw, (one top plate needs to be screwed with 2 screws)

Step3: #MM cover at the top. #NN and #OO need to be aligned closely with the top plate and beveled side and then screw on the #M screws

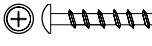
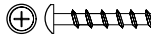
Step4: Put the #LL strip on the joint of the two top plates (the side with the smaller distance between the hole and the edge faces #MM), align the upper end with #MM, and then screw on the #T, #L screws. Then repeat this operation, insert the top plate #RR, #UU, tighten the lower end of the top plate with #L screw, then put #LL strip, and screw on #T, #L screw

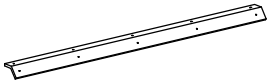
 沥青瓦片 (W) 2x 200*100mm	 (L) 44x M4*25mm	 (M) 18x M4*50mm	 (T) 40x M4*60mm
---	--	---	--

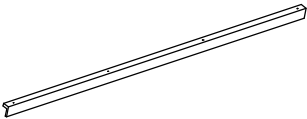
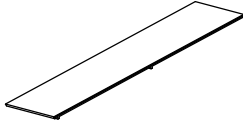
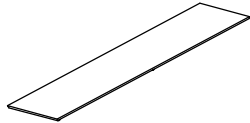
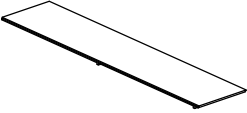
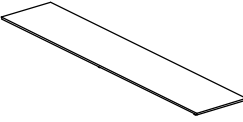
	MM X1		LL X6		OO X1
	NN X1		RR X2		SS X1
	UU X2		VV X1	Step12	

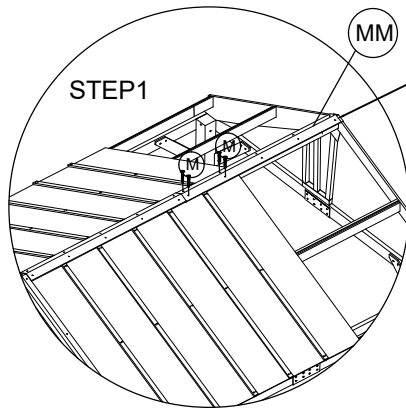

STEP1

#MM top cover asphalt shingles, and long side facing outwards

Step1: #MM cover at the top. Repeat the previous step, put the #LL strip, screw #T, #L screws, align the #OO, #NN cover with the top plate and the beveled side, then screw #M screws

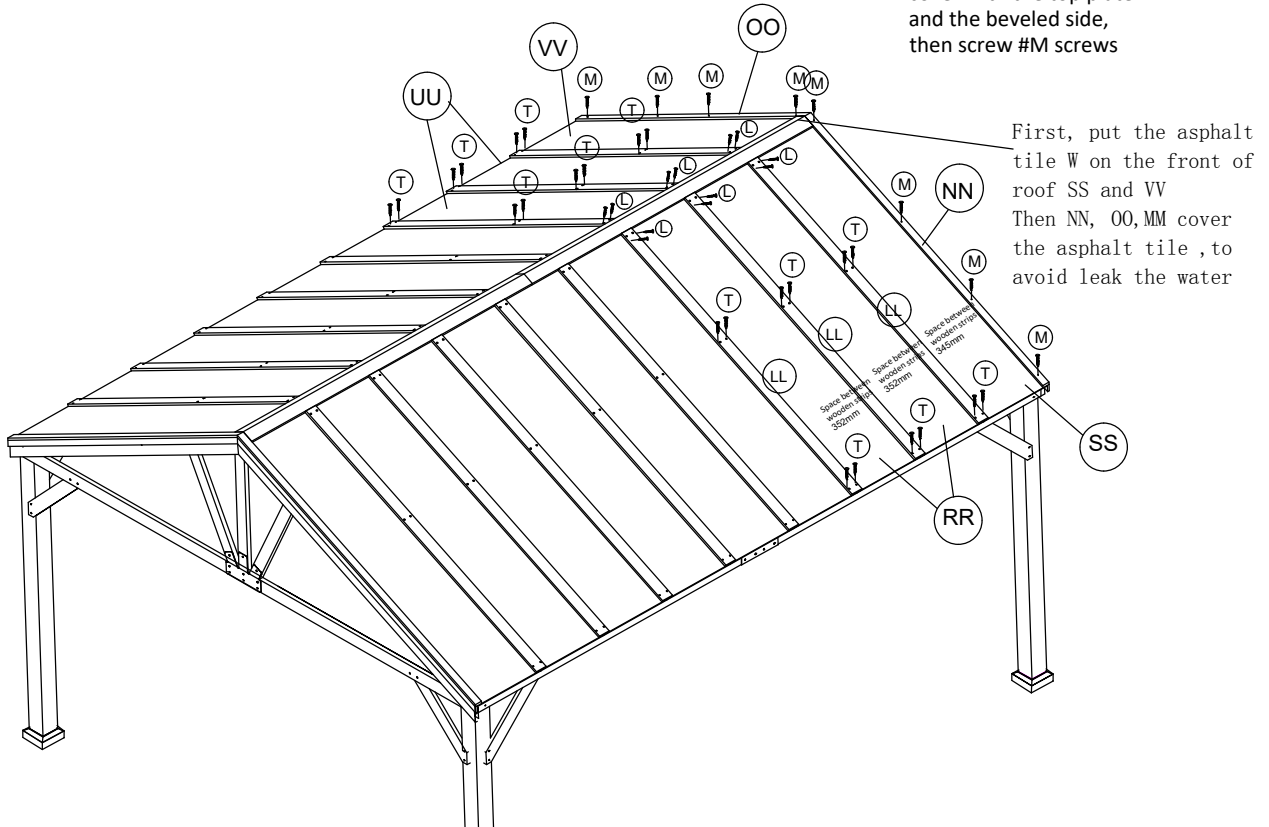

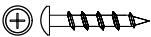
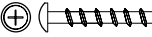
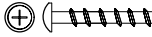
沥青瓦片  (W) 1x 200*100mm	 (L) 12x M4*25mm	 (M) 18x M4*50mm	 (T) 24x M4*60mm
---	--	---	--

Step13

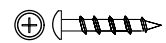
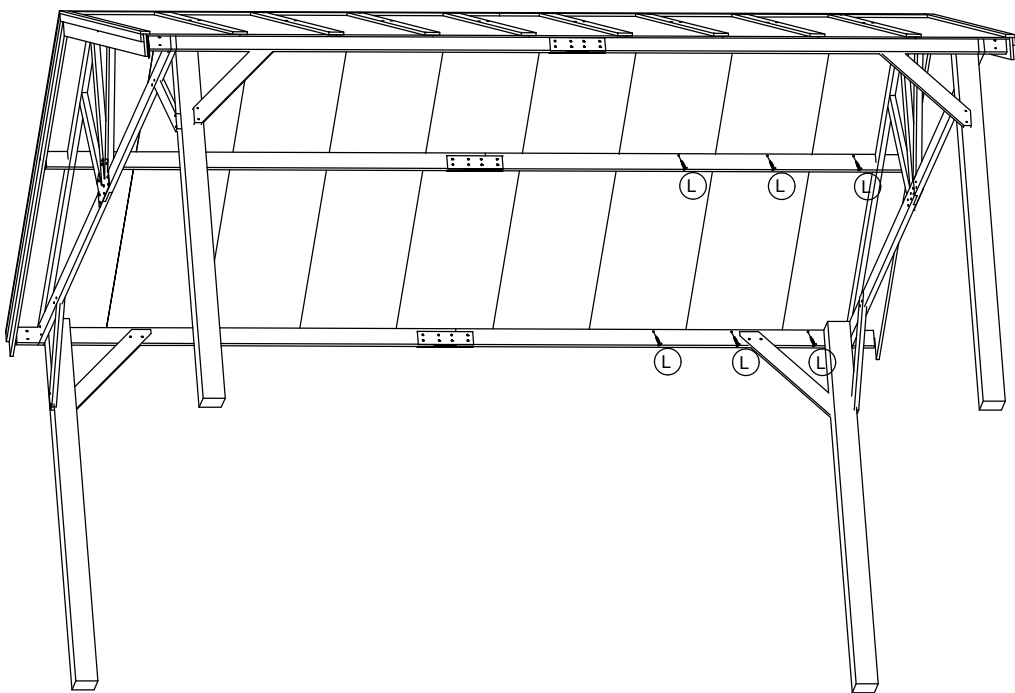

M4*25mm

L 12x

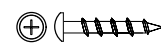
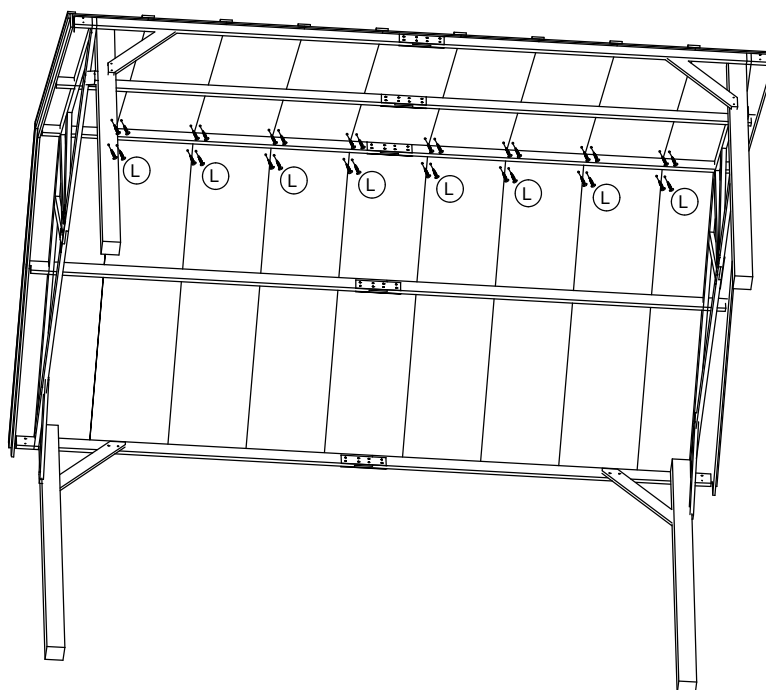

M4*25mm

L 32x

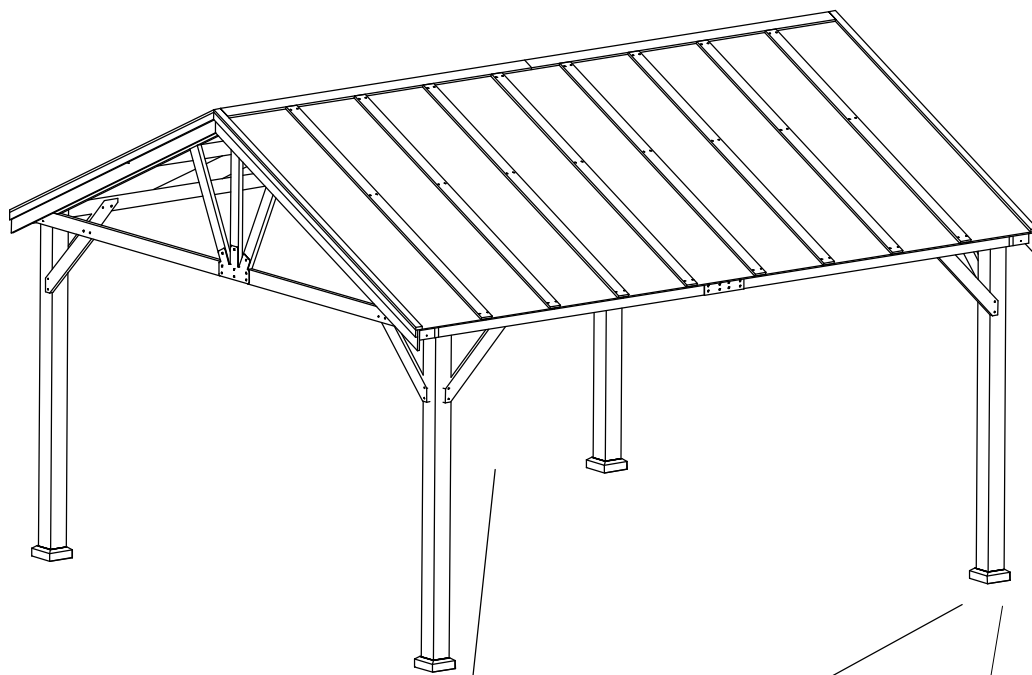

#S hooks can be freely assembled under the wooden beam

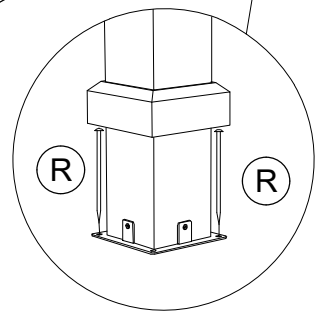
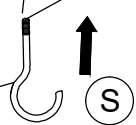

*You can choose where to mount the hooks according to your needs, but be careful when screwing the hooks into the wood or you may crack the wood slightly

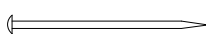
 M6*89mm S 4x	 ø8*180mm R 8x
--	---