

Vinyl Raised Garden Bed With legs

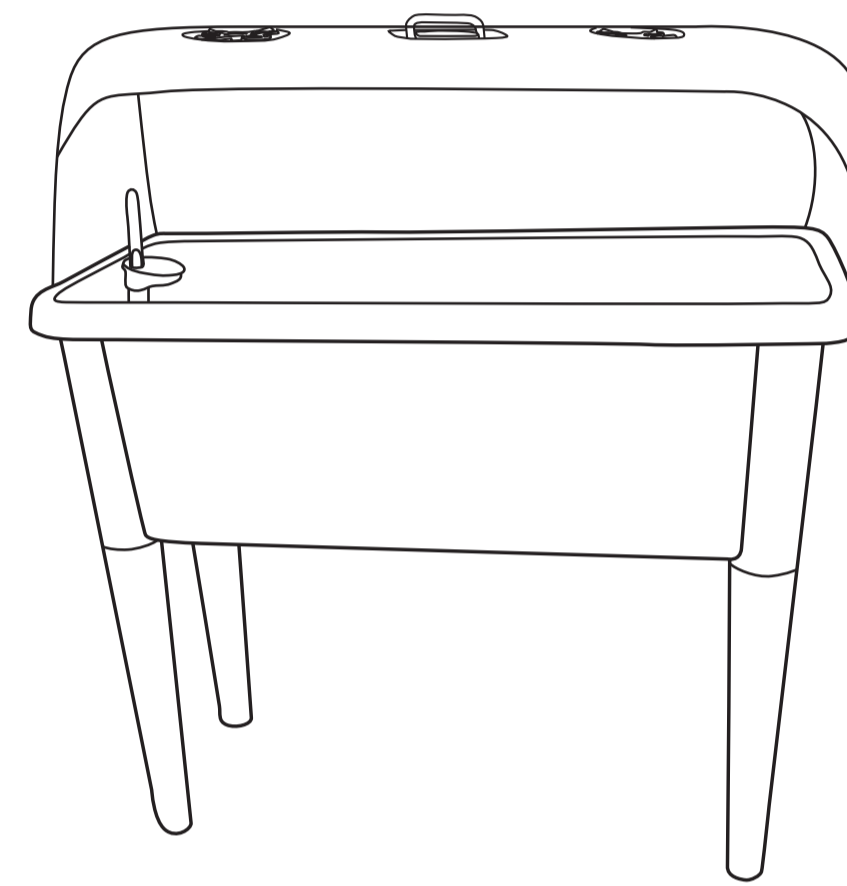

Instruction Manual

Congratulations!

We are glad that you have chosen to buy our products
We're sure that you'll not only grow healthy foods but you'll have fun too.

1. Grow your own healthy organic foods
2. Reduce your water consumption
3. Naturally control weeds
4. Plant earlier (the soil warms faster)
5. Parent-child education

Box contents

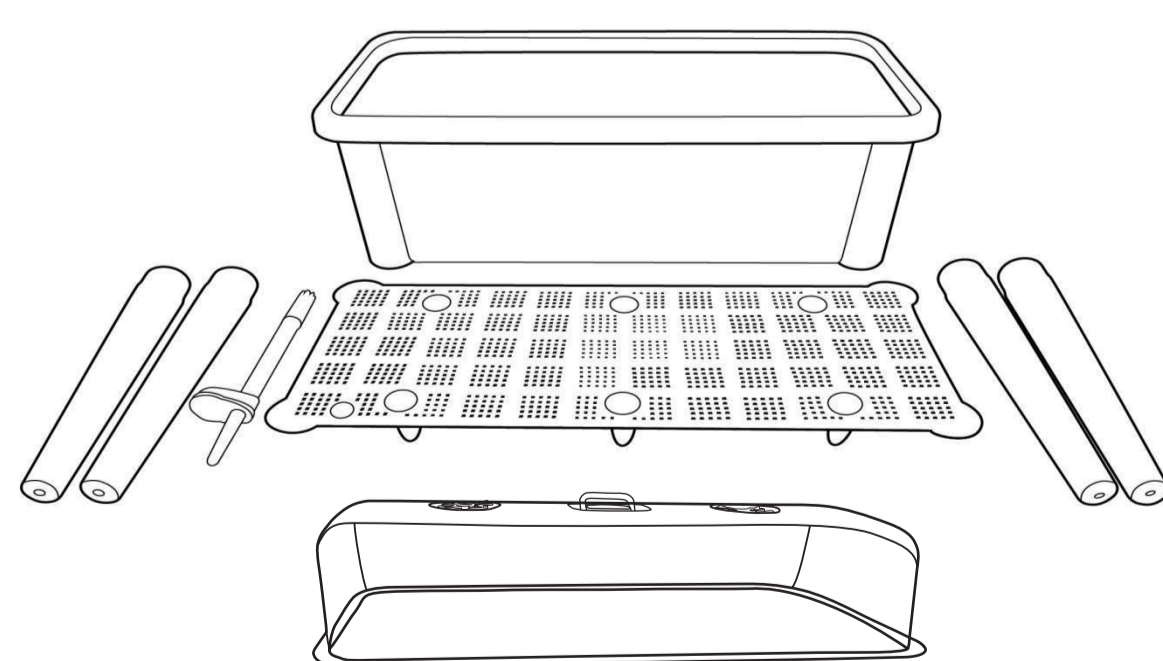

Step description

Follow these simple instructions to assemble your new Raised Garden.

