

LNT11

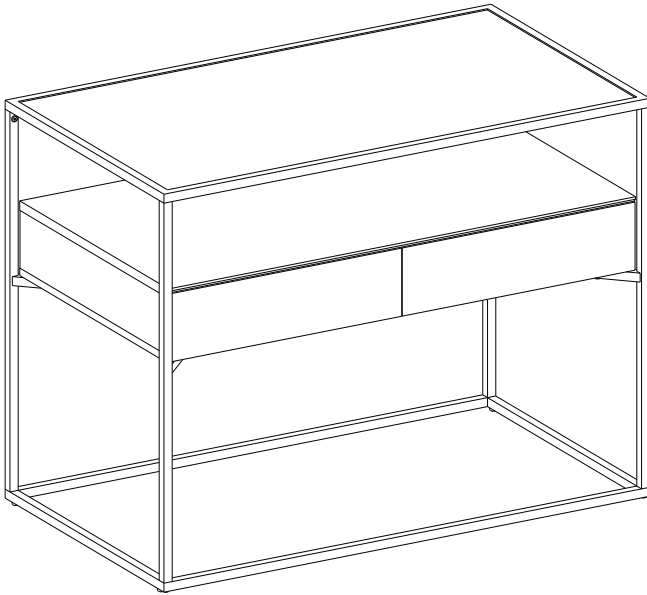

General Guidelines

- Please read the following instruction carefully and use the product accordingly.
- Please keep this manual and hand it over when you transfer the product.
- This summary may not include every detail of all variations and considered steps. Please contact us when further information and help are needed.

Notes

- It is recommended that two adults assemble the product. Please assemble this item strictly according to each step in the instructions.
- During assembly, first loosely align all screws with the corresponding pre-drilled holes and then tighten the screws one by one.
- Please use the product indoors and don't place it in a damp environment for extended periods of time to prevent mildew.
- Keep the product away from sharp objects or corrosive chemicals to prevent damage to the surface.
- Periodically inspect screw tightness while the product is in use. If necessary, re-tighten to ensure structural integrity.
- Do not hit or bump the tempered glass tabletop to prevent cracks.

Warnings

- During assembly, keep all small parts out of the reach of children. It may be fatal if swallowed or inhaled.
- Please do not use the product if there is/are defective and/or missing part/s, as this can result in damage or injury.
- To avoid the potential dangers of suffocation, please keep all parts and packaging (film, plastic bags, foam, etc.) away from babies and children.
- The maximum load capacity of the glass tabletop is 30 kg (66 lb). Please do not place overweight items on it.
- The toppling of furniture may cause serious or fatal injury. Please attach the product to the wall with the included anti-tipping hardware to avoid any potential hazards.
- Do not put heavy items in the drawer, as the center of gravity may shift after opening the drawer and cause the product to tip over, resulting in serious bodily injury.
- Children are not allowed to climb on the product, as this may cause the product to tip over and result in immeasurable injury.
- The included anti-tipping hardware is suitable for only solid walls. Please consult a professional hardware store and purchase a suitable anti-tip kit according to the type of your wall.
- Make sure all parts and screws are tightened for a stable structure before use to reduce safety hazards.

Einleitung

- Bitte lesen Sie die folgende Anleitung aufmerksam durch und verwenden Sie das Produkt sachgemäß.
- Bewahren Sie diese Anleitung gut auf und händigen Sie sie bei Weitergabe des Produkts an Dritte ebenfalls mit aus.

- Aus Gründen der Übersicht können nicht alle Details zu allen Varianten und denkbaren Montagen beschrieben werden. Wenn Sie weitere Informationen und Hilfe benötigen, kontaktieren Sie uns bitte.

Hinweise

- Der Zusammenbau sollte durch zwei Erwachsene erfolgen. Montieren Sie und benutzen Sie das Produkt bitte streng nach der Anleitung.
- Ziehen Sie die Schrauben bitte zuerst nicht an. Nachdem Sie alle Schrauben eingesetzt haben, schrauben Sie sie erst vorsichtig fest.
- Dieses Produkt ist nur für den Gebrauch in Innenräumen vorgesehen. Halten Sie das Produkt nicht langfristig in einer feuchten Umgebung, um Schimmel zu vermeiden.
- Halten Sie spitze Gegenstände und ätzende Chemikalien vom Produkt fern, da diese die Oberfläche beschädigen können.
- Prüfen Sie regelmäßig den festen Sitz der Schrauben und Verbindungen, falls notwendig nachziehen.
- Gewalteinwirkungen auf die Tischoberfläche aus Hartglas wie Schläge oder Stöße können zu Rissen im Glas führen und sind daher zu vermeiden.

Warnhinweise

- Halten Sie Kinder bei der Montage fern, da Kleinteile bei Verschlucken oder Einatmen tödlich sein können.
- Benutzen Sie das Produkt NICHT, wenn Teile beschädigt sind oder fehlen.
- Halten Sie Ihre Kinder von Verpackungsteilen wie Folien oder Plastikbeuteln fern, da Verpackungsteile oft nicht erkennbare Gefahren bergen (z. B. Erstickungsgefahr).
- Die max. Belastbarkeit der Glas-Oberfläche beträgt 30 kg, legen Sie keine zu schweren Gegenstände auf das Produkt.
- Das Umkippen von Möbelstücken kann zu schweren oder tödlichen Verletzungen führen. Bitte befestigen Sie das Produkt mit dem mitgelieferten Kippschutz an der Wand, um mögliche Gefahren zu vermeiden.
- Legen Sie keine schweren Gegenstände in die Schubladen, da sich der Schwerpunkt des Produktes nach dem Öffnen einer Schublade ansonsten verlagern könnte, was zum Umkippen des Produktes sowie zu schweren Verletzungen führen kann.
- Lassen Sie Kinder nicht auf das Produkt klettern, da das Produkt umkippen und es zu schweren Verletzungen kommen könnte.
- Der mitgelieferte Kippschutz ist nur für Massivwände geeignet. Wenden Sie sich im Falle von Wänden aus weniger festen Materialien an Fachpersonal und beziehen Sie einen weiteren Kippschutz, der den Gegebenheiten Ihrer Wand entspricht, über den Fachhandel.
- Stellen Sie vor der Benutzung des Produktes sicher, dass alle Einzelteile und Schrauben festgezogen wurden, um eine gute Stabilität zu gewährleisten und Sicherheitsrisiken zu verringern.

FR

Introduction

- Lisez attentivement ces instructions et utilisez votre produit d'après ce mode d'emploi.
- Conservez ces instructions. Si vous souhaitez offrir ce produit à un tiers, joignez obligatoirement ce mode d'emploi.
- Pour des raisons de clarté, les détails concernant chaque variante ou montage envisageable ne peuvent être

tous décrits. Si vous souhaitez obtenir plus d'informations ou si vous rencontrez certains problèmes non traités de manière détaillée dans ces instructions, veuillez nous contacter.

Notes

- L'assemblage doit être réalisé par deux adultes en suivant scrupuleusement de ce mode d'emploi.
- Lors du montage, veuillez bien positionner toutes les vis, ensuite effectuer un serrage progressif de l'ensemble des vis.
- Ce produit est conçu pour un usage à l'intérieur, et ne doit pas être placé dans un environnement humide pendant une longue durée pour éviter les moisissures.
- Évitez tout contact avec des objets pointus et corrosifs pour éviter d'endommager ce produit.
- Nous vous invitons à vérifier régulièrement les vis qui pourraient se desserrer progressivement pendant l'utilisation, ce qui risque de provoquer les dommages causés par un renversement du produit. Veuillez donc assurer que les vis sont toujours bien serrées.
- Ne frappez ni ne cognez le verre trempé pour éviter de provoquer les fissures.

Avertissements

- Les enfants ne sont pas autorisés à participer à l'assemblage de ce produit car il comprend de nombreuses petites pièces. L'inspiration ou l'ingestion de ces pièces présente un risque mortel.
- N'utilisez jamais ce produit dans le cas de manque ou défectuosité des pièces pour éviter le danger potentiel.
- Gardez toutes les pièces de l'emballage(films, sacs plastiques, polystyrènes, etc.) hors de la portée des enfants pour éviter les dangers potentiels (par ex. L'étouffement).
- La charge max du verre supérieur est de 30 kg, et ne dépassez pas sa limite.
- Le basculement d'un meuble peut provoquer des blessures graves, même des accidents mortels. Il est impératif de le fixer au mur à l'aide des dispositifs anti-basculement fournis pour éviter des dangers potentiels.
- Ne rangez pas d'objets lourds dans les tiroirs, car le centre de gravité pourrait se déplacer après l'ouverture du tiroir et le meuble perd son équilibre, ce qui pourrait provoquer des blessures graves.
- Il est interdit aux enfants de grimper sur le meuble, car cela pourrait faire basculer le meuble et provoquer des blessures graves.
- Le dispositif anti-basculement fourni s'adapte uniquement aux murs durs. Si les matériaux de construction du mur sont spacieux, renseignez-vous auprès d'un fournisseur professionnel.
- Avant l'utilisation du meuble, vérifiez le serrage de toutes les pièces et les vis pour une bonne stabilité.

IT

Linee guida generali

- Si prega di leggere attentamente le seguenti istruzioni e usare il prodotto in modo opportuno.
- Si prega di conservare questo manuale e consegnarlo quando il prodotto cambia proprietario.
- Questo riassunto potrebbe non includere ogni dettaglio di tutte le variazioni e le fasi considerate. Contattaci se hai bisogno di ulteriori informazioni e assistenza.

Note

- Si raccomandano due persone per assemblare il prodotto. Si prega di seguire attentamente i passaggi descritti.
- Non stringere completamente le viti fino a quando tutte le viti sono allineate con i fori preforati corrispondenti.
- Il prodotto è inteso per uso interno. Si prega di evitare un'esposizione prolungata ad ambienti umidi per prevenire la formazione di muffa.
- Evitare il contatto con oggetti appuntiti e sostanze chimiche corrosive per prevenire danni al prodotto.
- Controllare regolarmente le viti, potrebbero allentarsi durante l'uso. Se necessario, stringerle di nuovo per garantire stabilità e sicurezza.
- Non urtare il piano del tavolo in vetro temperato per evitare lesioni personali.

Avvertenze

- Impedire ai bambini di assemblare il prodotto. Durante l'assemblaggio, tenere le parti di piccole dimensioni fuori dalla portata dei bambini, potrebbero essere fatali se ingerite o inalate.
- Si prega di non utilizzare il prodotto in caso di parti difettose e/o mancanti, in quanto ciò può causare danni o lesioni.
- Tenere gli imballaggi di plastica fuori dalla portata dei bambini per evitare qualsiasi potenziale pericolo, come il soffocamento.
- La capacità di carico massima del piano di tavolo in vetro temperato è 30 kg. Non appoggiare oggetti oltre questo limite.
- Il ribaltamento dei mobili può causare lesioni gravi o mortali. Assicurarsi di utilizzare gli accessori antiribaltamento inclusi per fissare il prodotto alla parete per evitare potenziali pericoli.
- Non mettere oggetti pesanti nel cassetto, poiché il baricentro potrebbe spostarsi dopo l'apertura del cassetto e causare il capovolgimento del prodotto, con conseguenti gravi lesioni personali.
- È vietato ai bambini di salire sul prodotto, in quanto ciò potrebbe causare il ribaltamento del prodotto e provocare lesioni incommensurabili.
- Gli accessori anti-ribaltamento inclusi sono adatti solo per pareti solide. Si prega di consultare un negozio di ferramenta professionale e acquistare un kit anti-ribaltamento adatto in base al tipo di muro.
- Assicurarsi che tutte le parti e le viti siano serrate per una struttura stabile prima dell'uso per ridurre i rischi per la sicurezza.

ES

Acerca del manual

- Por favor, lea detenidamente las instrucciones y respete los debidos usos del producto.
- Por favor, conserve bien este manual y en caso de cesión, no omita entregarlo junto al producto.
- Este manual podría no incluir todos los detalles de cada paso del montaje. Si necesita ayuda o información adicional, póngase en contacto con nosotros.

Notas

- Se recomienda que dos adultos ensamblen el producto. Por favor, ensamble el producto estrictamente de acuerdo con cada paso de las instrucciones.
- Durante el montaje, alinee primero todos los tornillos con los orificios pretaladrados correspondientes, a continuación, apriete los tornillos uno por uno.
- Por favor, use el producto en interiores y no lo coloque en un ambiente húmedo durante largos períodos de

tiempo para prevenir el moho.





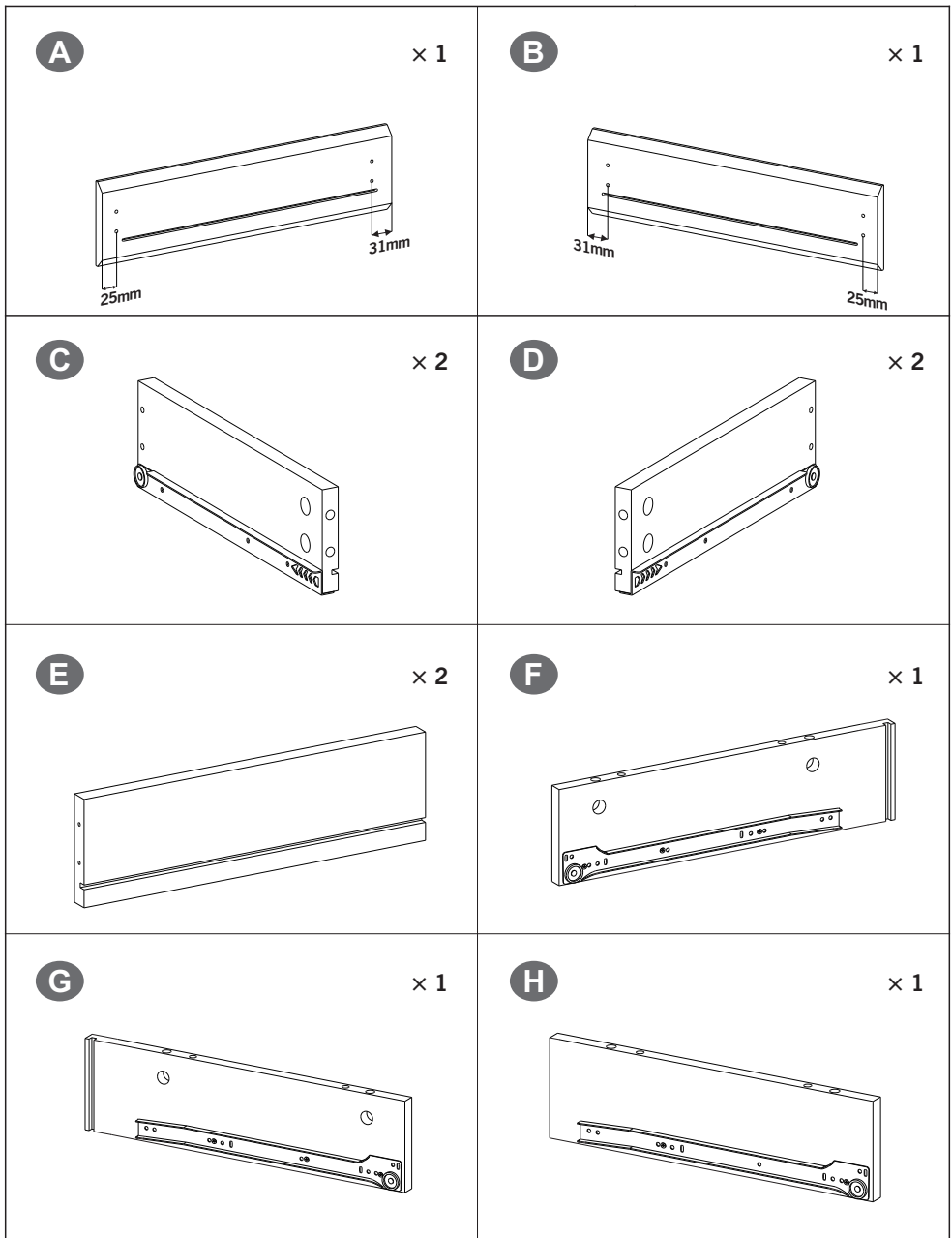

- Mantenga el producto alejado de objetos punzantes o productos químicos corrosivos para evitar daños en la superficie.
- Inspeccione periódicamente el ajuste de los tornillos mientras el producto esté en uso. Si es necesario, vuelva a apretar para asegurar la integridad estructural.
- No golpee la superficie de la mesa de vidrio violentamente para evitar lesiones personales.

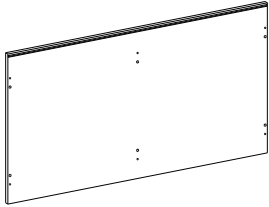
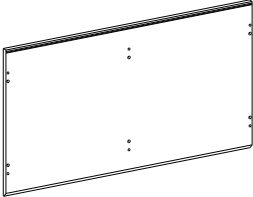
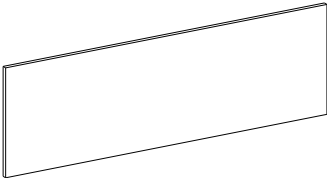
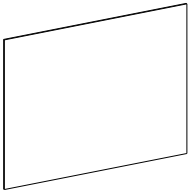
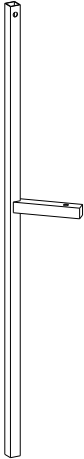
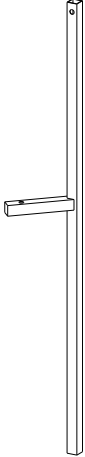

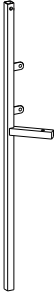
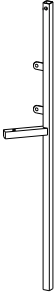
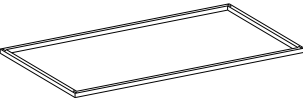

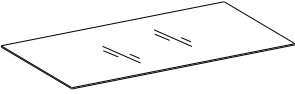
Advertencias

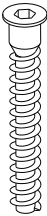
- Durante el montaje, mantenga todas las piezas pequeñas fuera del alcance de los niños. Puede ser mortal si se ingiere o inhala.
- Por favor, no utilice el producto si está defectuoso y/o le faltan piezas, ya que esto puede ocasionar daños o lesiones.
- Para evitar los peligros potenciales de asfixia, mantenga todas las piezas y embalajes (películas, bolsas de plástico y espuma, etc.) fuera del alcance de los bebés y los niños.
- La capacidad de carga máxima de cristal es de 30 kg. Por favor, no coloque artículos con sobrepeso en él.
- El vuelco de los muebles puede causar lesiones graves o mortales. Por favor, sujete el producto a la pared con las herramientas antivuelco incluidas para evitar cualquier riesgo potencial.
- No coloque objetos pesados en el cajón, ya que el centro de gravedad puede desplazarse después de abrir el cajón y provocar que el producto se vuelque, lo que puede ocasionar lesiones corporales graves.
- No se permite que los niños se suban al producto, ya que esto puede causar que el producto se vuelque y resulte en lesiones incommensurables.
- Las herramientas antivuelco incluidos son adecuadas sólo para paredes sólidas. Por favor, consulte a una ferretería profesional y compre un kit antivuelco adecuado según el tipo de pared.
- Asegúrese de que todas las piezas y tornillos estén apretados para obtener una estructura estable antes de usarlos para reducir los riesgos de seguridad.

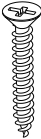

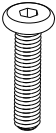
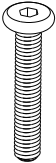
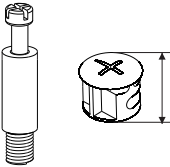
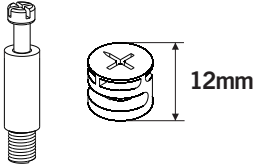
<p>I × 1</p>  A rectangular panel with a slight upward curve. It has two vertical lines of pre-drilled holes: one on the left side and one in the center. There are also two pairs of small holes on the right side, one pair near the top and one pair near the bottom.	<p>J × 1</p>  A rectangular panel with a slight downward curve. It has two vertical lines of pre-drilled holes: one in the center and one on the right side. There are also two pairs of small holes on the left side, one pair near the top and one pair near the bottom.
<p>K × 1</p>  A simple rectangular panel with a slight upward curve and no pre-drilled holes.	<p>L × 2</p>  A simple rectangular panel with a slight downward curve and no pre-drilled holes.
<p>M × 1</p>  A long vertical post with a small hole at the top. A shorter horizontal piece is attached to the side of the post, positioned about halfway down.	<p>N × 1</p>  A long vertical post with a small hole at the top. A shorter horizontal piece is attached to the side of the post, positioned about halfway down. This post is slightly longer than post M.

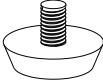
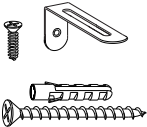
<p>O × 1</p> 	<p>P × 1</p> 	<p>Q × 1</p> 
<p>R × 1</p> 	<p>S × 1</p> 	<p>2 12+2</p> 
<p>3 6+1</p> 	<p>4 4+1</p> 	<p>6 8+2</p> 

<p>8 4+1</p>  <p>M6 × 12 mm</p>	<p>10 4+1</p>  <p>M6 × 28 mm</p>	<p>12 4+1</p>  <p>M6 × 40 mm</p>
<p>19 8+2</p>  <p>10mm</p>	<p>20 6+1</p>  <p>12mm</p>	<p>26 × 1</p> 
<p>27 × 1</p> 	<p>28 × 4</p> 	<p>30 × 2</p> 
<p>33 6+3</p> 		

Tools Required:

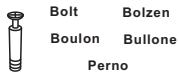
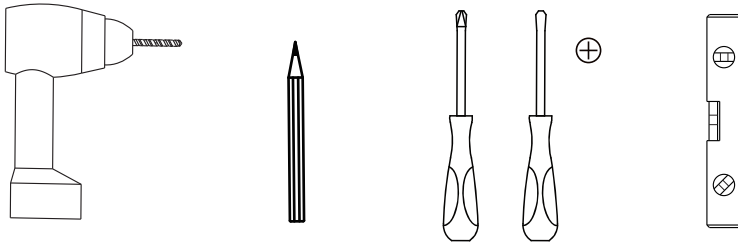

Bolt Bolzen
Boulon Bullone
Perno



Connecting piece
Verbindungsbeschlag
Pièce de raccord
Pezzo di bloccaggio
Pieza de sujeción

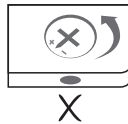

Adjust connecting piece direction until it is properly lined up with the hole.

Stellen Sie die Richtung des Verbindungsbeschlags ein, falls der Zustand wie dargestellt

Ajustez l'écrou selon le schéma

Regolare la direzione di pezzo di collegamento come la condizione illustrata

Ajustar la pieza de sujeción según la dirección ilustrada

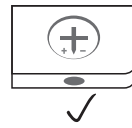

Insert bolt when connecting piece direction is properly lined up.

Stecken Sie den Bolzen in diesem Zustand ein

Insérez le boulon quand la pièce de raccord est dans telle condition

Inserire il bullone quando il pezzo di collegamento è in tale condizione

Insertar el perno cuando se encuentre así la pieza de sujeción

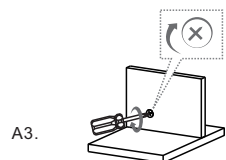
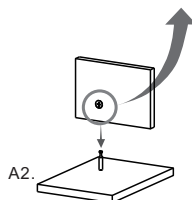
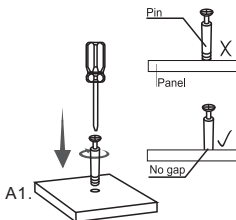

1

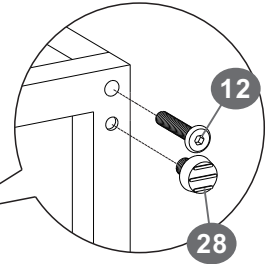
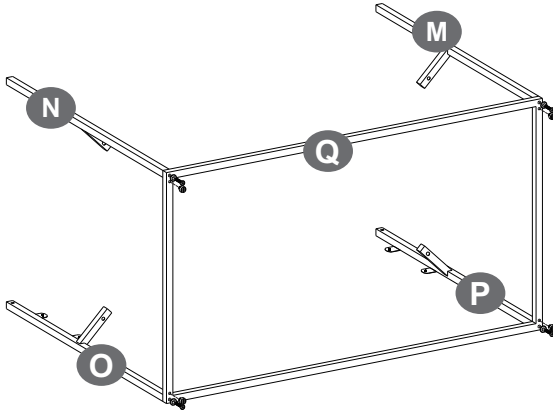

12



4PCS

28



4PCS

2

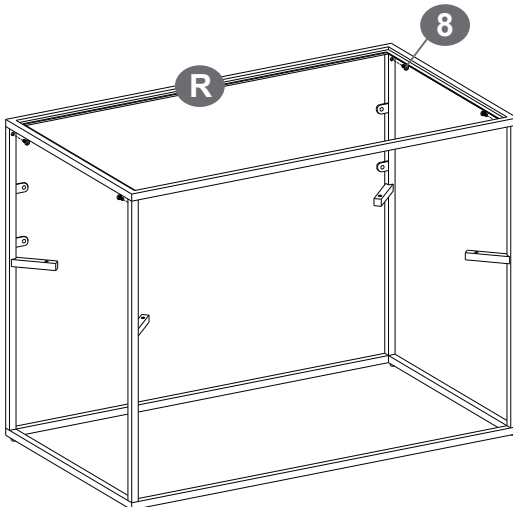

8



4PCS

3

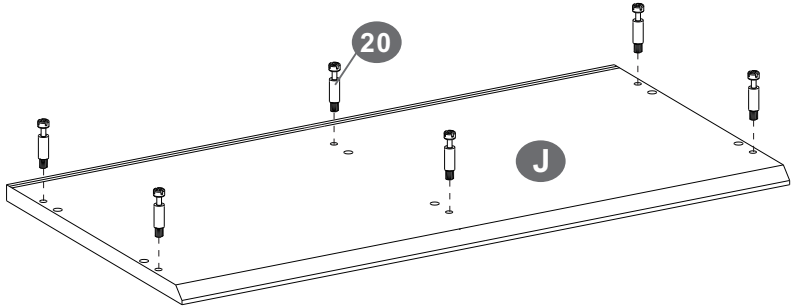

20



6PCS

4

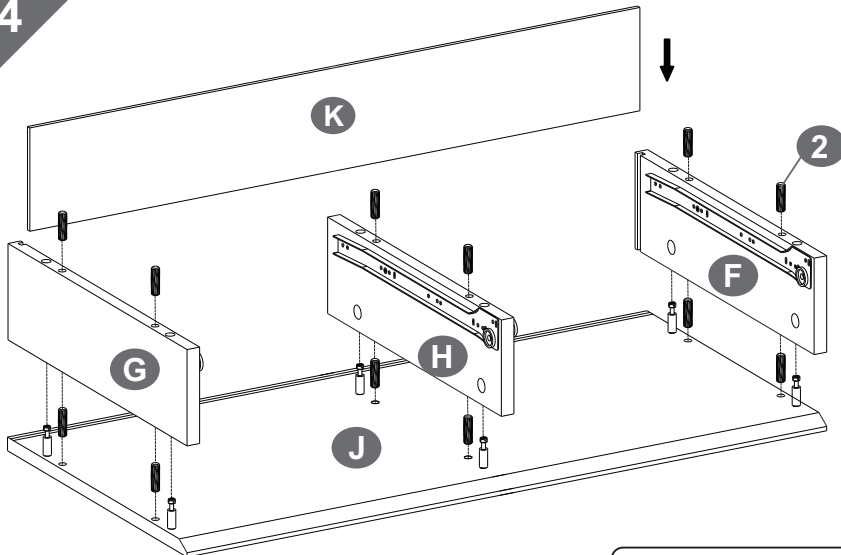

2



12PCS

5

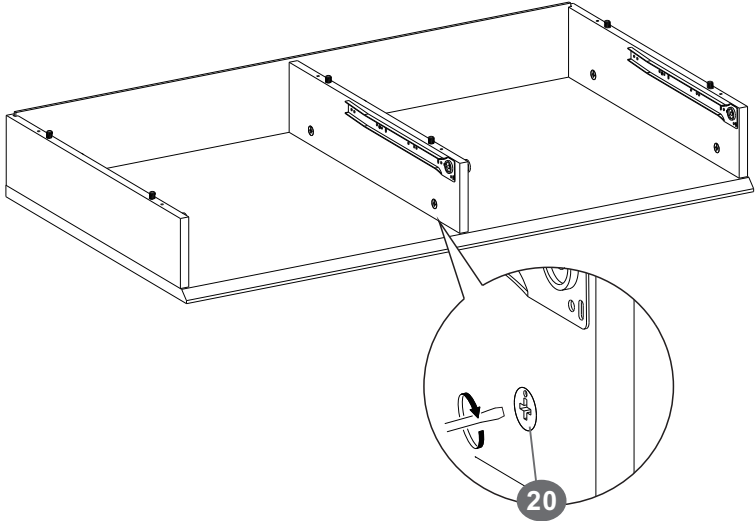

20



6PCS

6

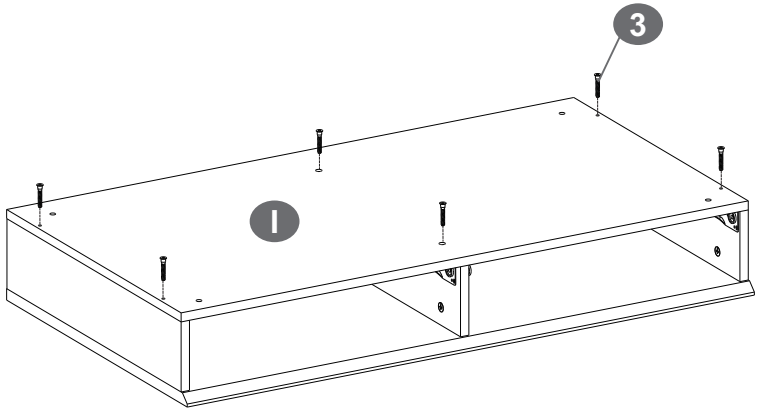

3



6PCS

7

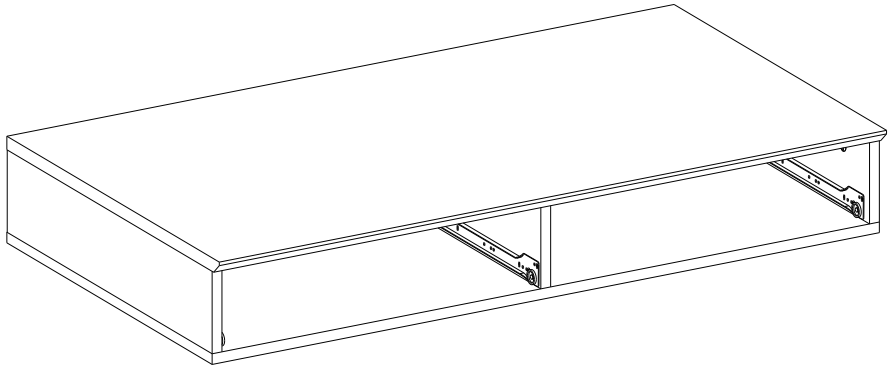

8

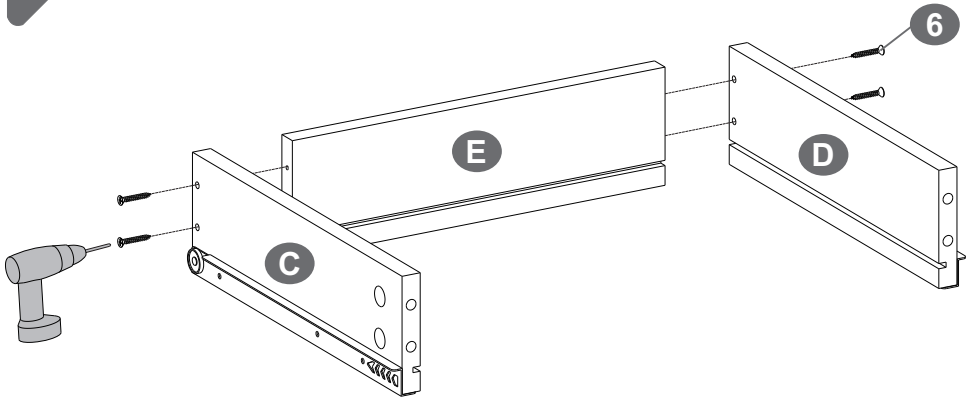

×2

6



4PCS

9

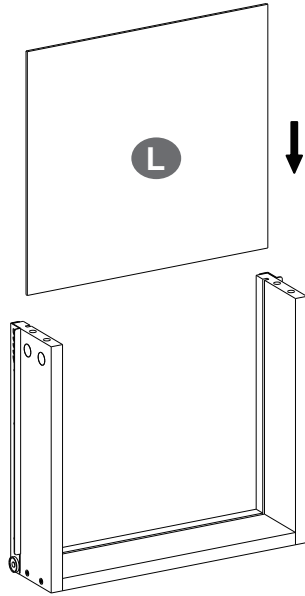

×2

10

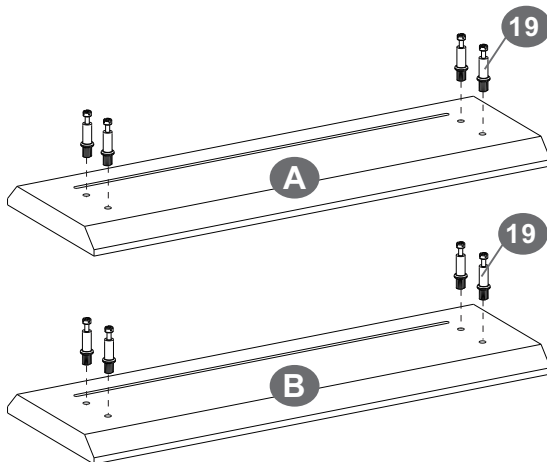

19



8PCS

11

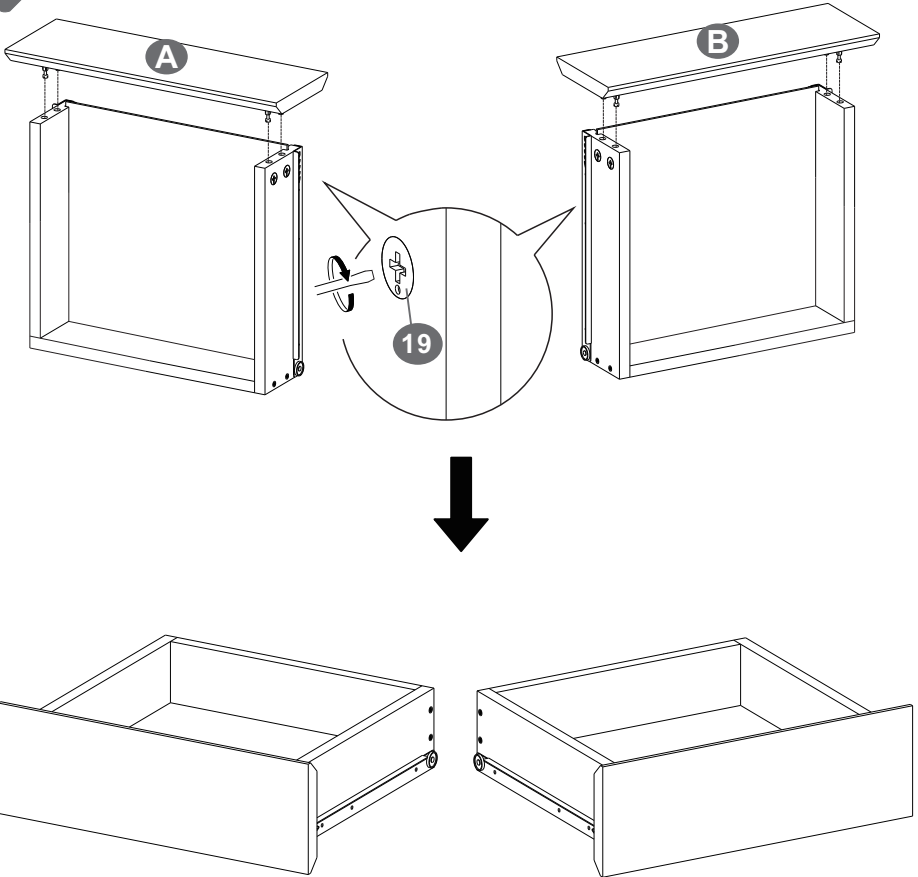

19  8PCS

12

- It is suggested that you place a foam board under the product to raise the wooden box a little higher to facilitate the assembly.

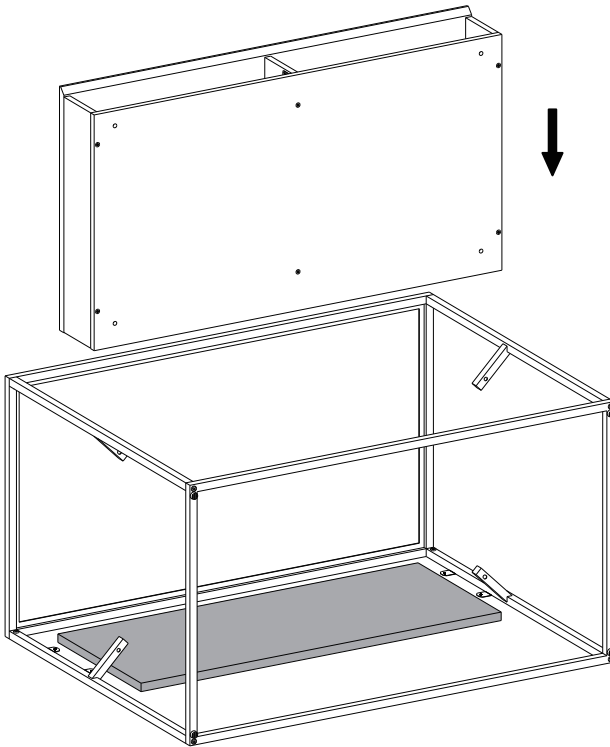

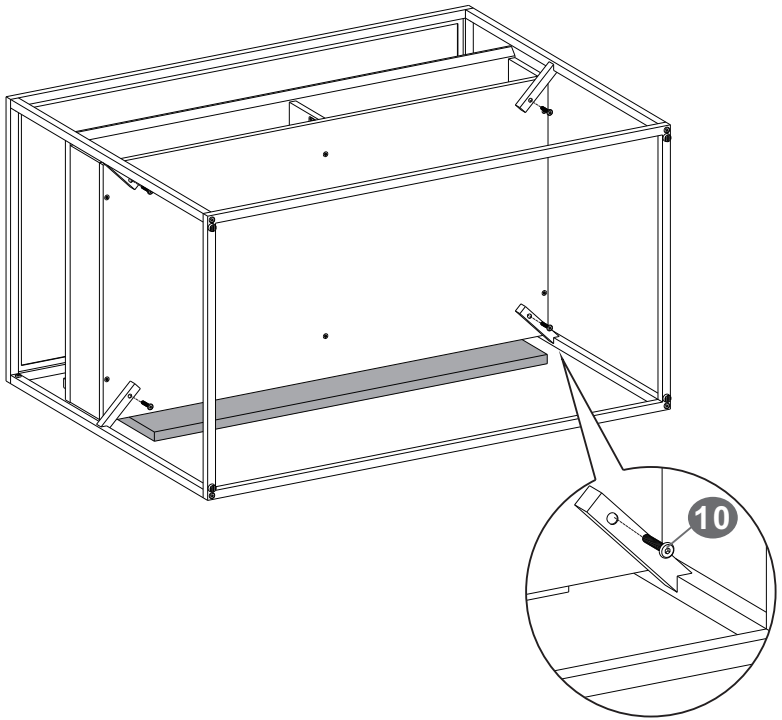

13

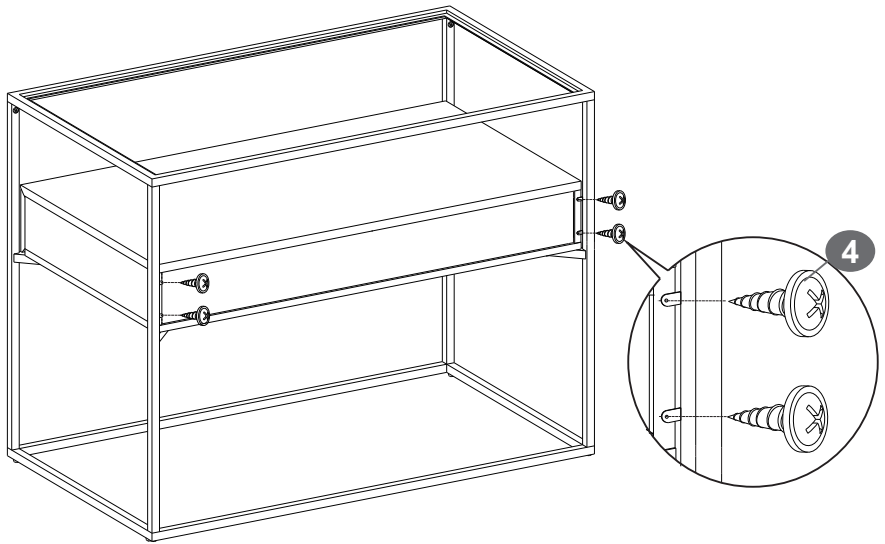

10		4PCS
-----------	---	------

14



4  4PCS

15

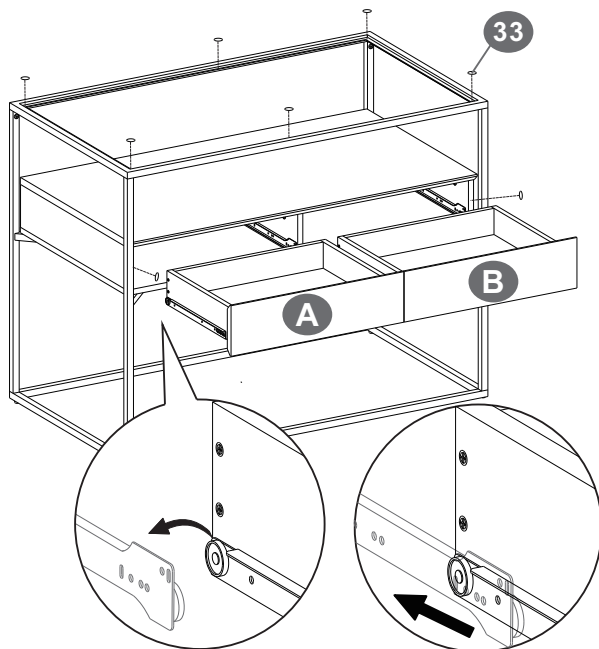

16

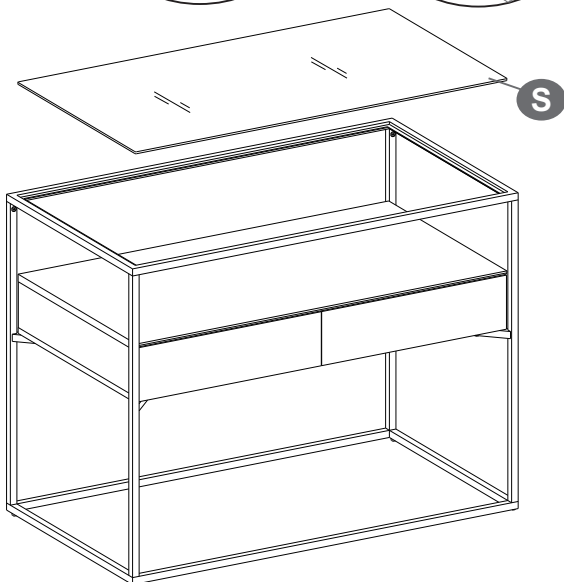

17

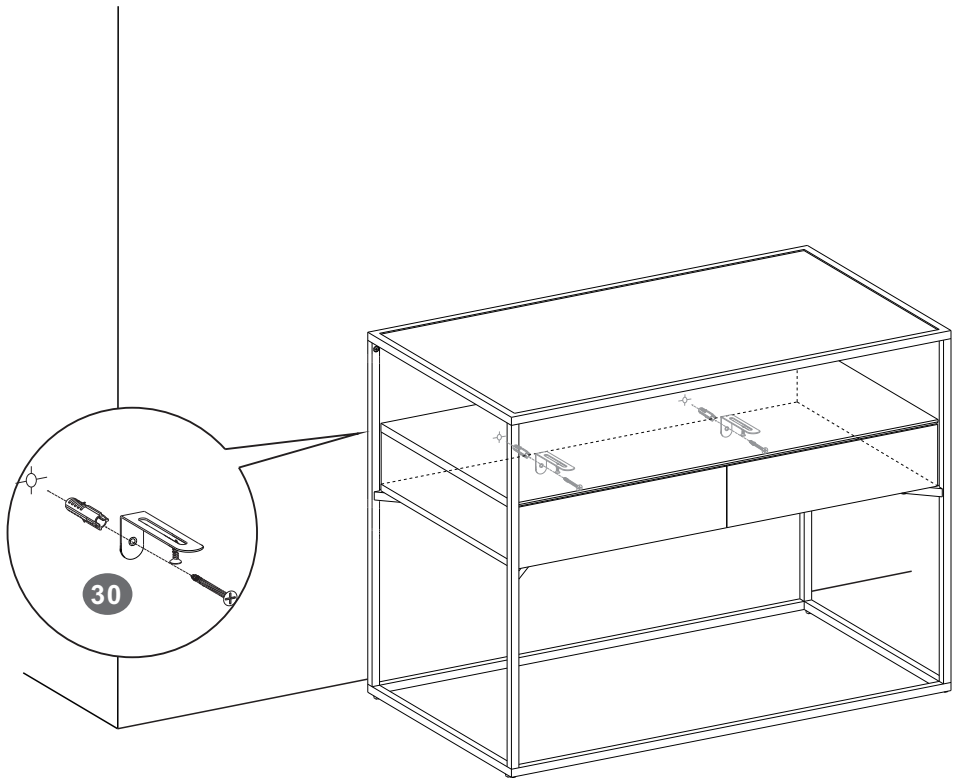

30



2PCS