

CMBasic



The BasicLine by Grundfos CMBasic is a compact booster pump designed for domestic and light industrial use. The booster unit consists of a Grundfos CM cast iron pump with stainless steel hydraulic components and PM1 Pressure Manager. The Pressure Manager allows the pump to start and stop automatically according to demand and protects the pump from dry running.



FEATURES

Robust design

All moving parts are made from high quality, corrosion resistant stainless steel to ensure the longest life possible.

User-friendly interface

The pump features a user-friendly interface with LED indicators displaying power status, pump running, and alarm indication.

Protective features

The pump incorporates a range of protective features such as dry run protection, thermal overload protection, and cycling alarm to protect the pump and ensure a long life.

Easy installation

The booster unit is a compact solution, which makes it suitable for most installations. Simply connect the inlet and outlet and you have a fully operational booster unit.

Integrated non-return valve

Non-return valve for backflow prevention.

APPLICATIONS

- Household water supply
- Boosting from above ground water tanks
- Light industrial use



PERFORMANCE

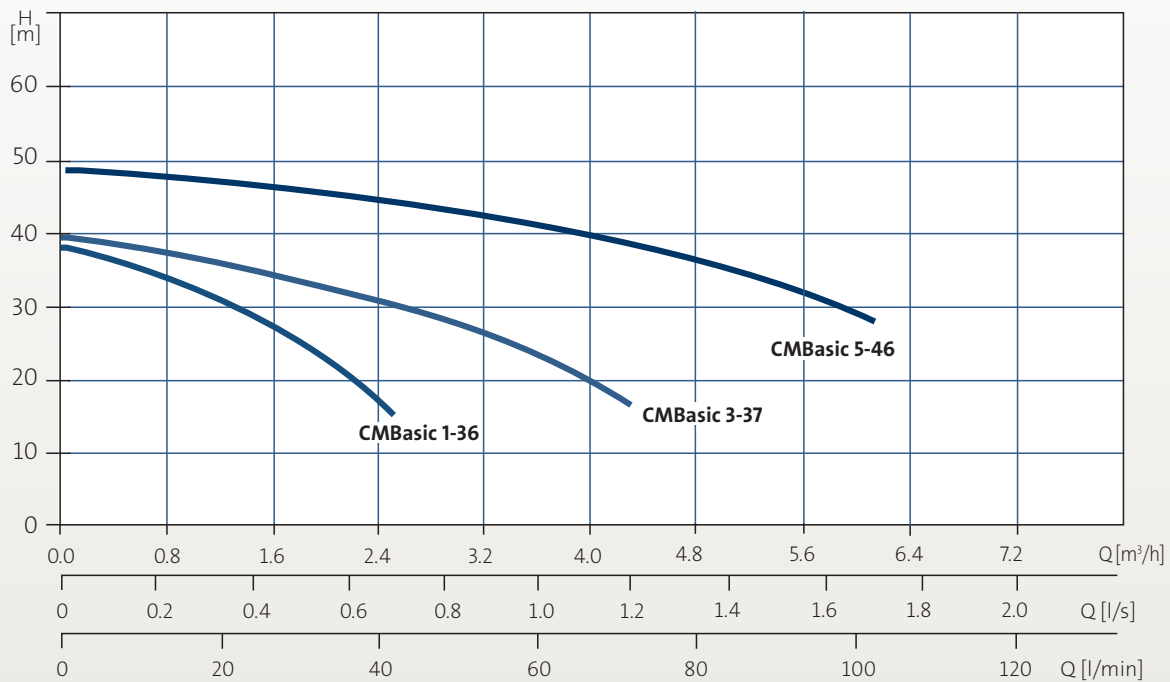

OPERATING CONDITIONS

System pressure

Max. 10 bar

Liquid temperature

0 °C to 60 °C

Ambient temperature

Max. 55 °C

Relative air humidity

Max. 95 %

TECHNICAL DATA

Mains voltage

1 x 240 V, 50 Hz

Enclosure class

IP55

Insulation class

F

Sound pressure level

50-60 dB

Start/stop frequency

Max. 100 per hour

Approvals and markings

CE

DIMENSIONS

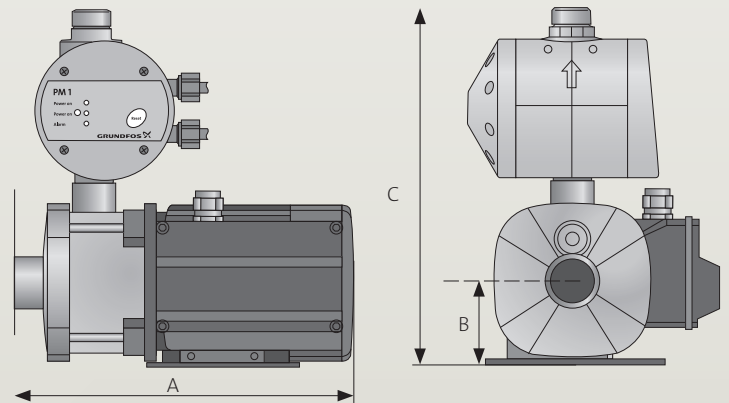

Model	Power (kW)	Connections		Dimensions (mm)			Weight (kg)
		Outlet	Inlet	A	B	C	
CMBasic 1-36	0.5	1" M	1" F	323	75	317	13.3
CMBasic 3-37	0.5	1" M	1" F	323	75	317	13.3
CMBasic 5-46	0.9	1" M	1¼" F	381	75	317	16.0