



The Big Boy

Flamethrower

User Manual

V 2022.10.1



CONTENTS

SPECIFICATIONS.....	2
DISCLAIMER.....	2
GENERAL SAFETY WARNINGS.....	3
PRODUCT DESCRIPTION.....	6
OPERATING INSTRUCTIONS.....	7
CHARGING THE BATTERIES.....	9
STORAGE.....	11
LIMITED LIFETIME WARRANTY.....	11
FCC COMPLIANCE.....	12

The Big Boy Flamethrower

User Manual

Specifications:

Model: The Big Boy
Rated Voltage: 18-24V DC
Rated Current: 50A
Throw Distance: 45-50 Feet
Battery Life: 10 Minutes Continuous Fire
Dimensions: 40" x 12" x 16"

Includes: (1) Prometheus Industries Carry Case, (1) Big Boy Flamethrower, (1) battery charger, (1) battery cell balancing cable, (1) battery charging cable.



WARNING: To reduce the risk of injury, all users must read and understand this operator's manual before operating this device. Save this Manual for future reference.

DANGER FIRE FUMES OZONE PLASMA

READ ALL WARNINGS AND INSTRUCTIONS BEFORE USING YOUR PRODUCT. DO NOT DISCARD THESE WARNINGS AND INSTRUCTIONS

DISCLAIMER:

Prometheus Industries will not be responsible or liable for any damages you or any third party may suffer as a result of use or misuse of this product.

General Safety Warnings

This flamethrower uses gasoline, which is a flammable product. Failure to comply with these warnings and instructions may result in an explosion or fire that may cause property damage, personal injury, or death.

Read the instructions and warnings in this manual and familiarize yourself with the flamethrower before using. Review instructions and warnings periodically to maintain awareness. Do not try to operate the flamethrower before reading instructions.

- Keep the flamethrower out of reach of children and anyone who has not read instructions. Do not point the flamethrower towards self, other persons, animals, or objects. Never attempt to use the flamethrower as a cigarette lighter..
- Never attempt to modify the flamethrower construction, and never use unapproved accessories or fuels.
- Treat the flamethrower as you would any fine tool or instrument. Do not drop, throw, or otherwise abuse.
- Do not use a leaking, damaged, or malfunctioning flamethrower.
- Wear safety glasses and protective gear when using the flamethrower.
- Radiant energy can harm your eyes. Wear glasses with an appropriate lens shade number.
(see OSHA Standard contained in 29 CFR 1926.102)
- Only use the flamethrower in well-ventilated areas.

General Safety Warnings

- Never use the flamethrower near combustibles. Be careful around motor vehicles or any gasoline-fired products and beware of hidden fuel lines and tanks. Do not attempt to ignite combustibles using plasma.
- Be careful when using the flamethrower on windy days. Wind may carry the flamethrower's heat back toward you or other areas not intended to be heated. Windy conditions may also cause sparks to be blown into other areas with combustible materials.
- Heating an object may cause heat to be conducted to adjacent objects that may be combustible or become pressurized when heated. Always check to make sure no unintended objects are being heated.
- Do not touch the tip of the flamethrower. It can get extremely hot during use. Take precautions to protect yourself and others from accidental burns. Do not touch plasma.
- Never leave the flamethrower unattended when turned on.
- Always have a fire extinguisher and a bucket of water nearby when you use the plasma thrower.
- This plasma thrower consumes oxygen and must only be used in well ventilated areas. Do not use it in a confined place.
- Do not use if you have a pacemaker. The electrical arc produces significant radio noise, and any impact it could have on life-support devices has not been thoroughly tested.

General Safety Warnings

- Only charge batteries with the accompanying battery charger.
- Do not use in the rain or when relative humidity exceeds 75%
- Do not place the device on the ground while attempting to start the ignition process.
- Do not put face or hands near the plasma.
- Do not stare at plasma.
- Only use fuels approved by Prometheus Industries. The optimal fuel that we have found is diesel fuel.

Product Description

- (1) Plasma Vortex
- (2) Brass Cathode
- (3) Protective Shroud
- (4) Plasma Button
- (5) Fuel Pump
- (6) Power Settings
- (7) Gas Button
- (8) Battery
- (9) Fuel Tank Entry
- (10) Kill Switch

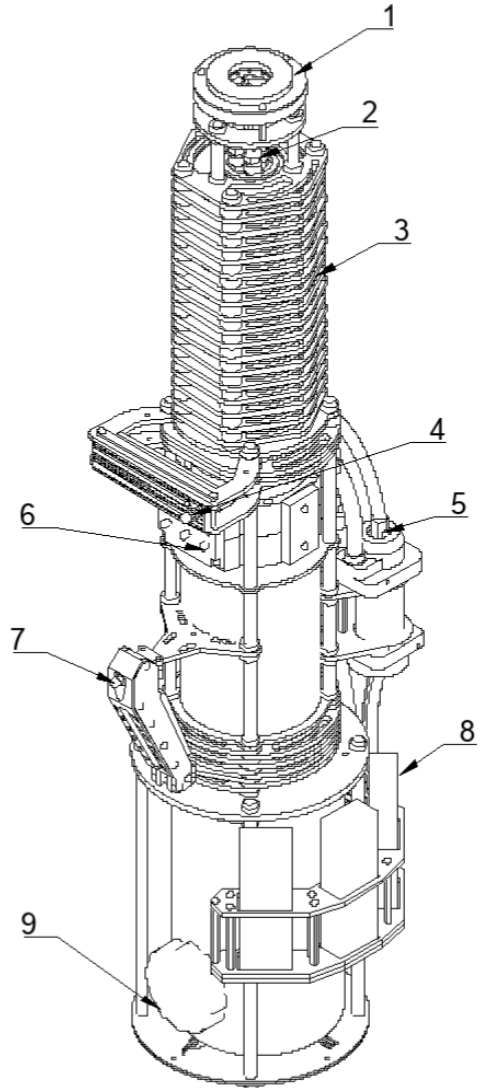

(Fig. 1)

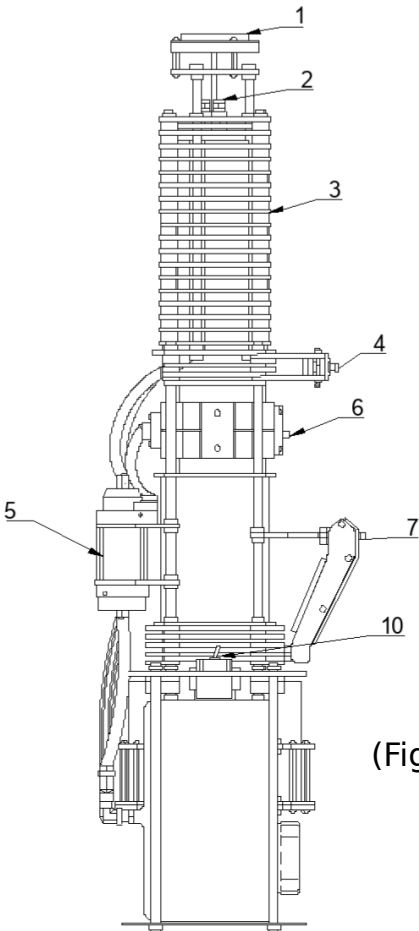

(Fig. 2)

Product Description

Plasma Vortex - This is where the fuel gets ignited. Careful, the voltage is about 30,000V!

Brass Cathode - Carries the charge to the gap

Protective Shroud - Prevents a user from touching any of the high voltage components

Plasma Button - A basic on/off switch that controls whether the plasma is running.

Fuel Pump - Pumps the fuel through the hoses

Power Settings - The 3 buttons are used to set the power level: low, med, and high. The LEDs indicate the current power level.

Gas button - A basic on/off switch that controls whether fuel is being discharged or not.

Battery - Powers the system

Fuel Tank Entry - This is where you pour in fuel

Power Switch - Activates or Deactivates the Flamethrower. Nothing will happen if this switch is set to "OFF"

Operating Instructions



(Scan To See A Video)

1. Inspect the ignition assembly and verify that no wires are damaged or out of place.

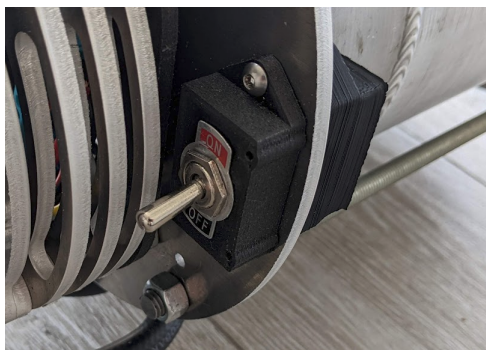

2. Power on the system by flipping the kill switch (10) to “ON”. The color of the LEDs corresponds to the amount of battery life remaining.

RED: 0 - 30%

YELLOW: 30 - 69%

GREEN: 70 - 100%

3. Pour the fuel into the gas tank. For best results, use diesel fuel. Diesel/Gas mixtures may cause a small flame at the ignition area



Operating Instructions

4. Grab the plasma handle with your left hand, and the gas handle with your right hand.

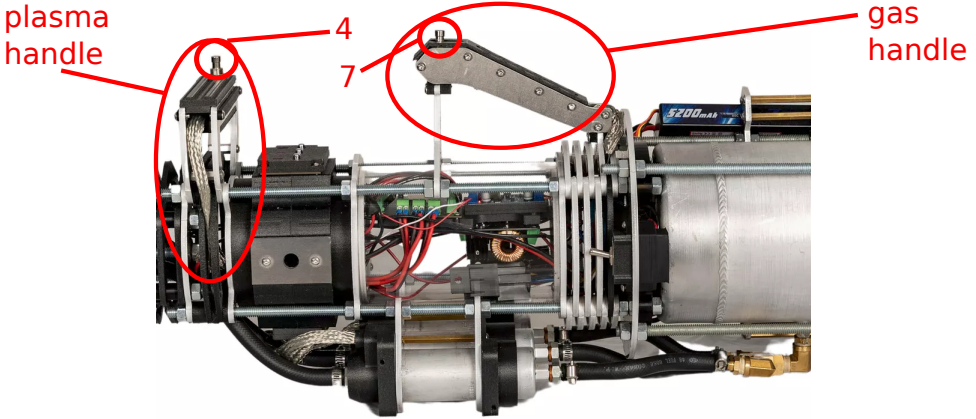

5. Point the flamethrower in a safe direction and press the plasma switch (4) to create the high voltage plasma.

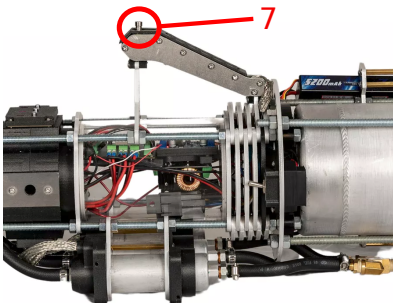
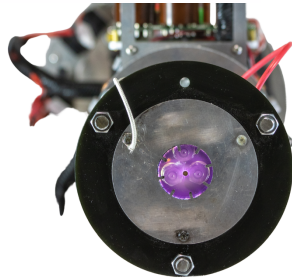

6. Press the gas trigger (7).
Be ready for fire!

7. Release the gas trigger (7) to stop shooting gas, then release the plasma switch (4) to stop creating plasma.

8. Power off the system by setting the power switch (10) to the "OFF" position.

Charging the Batteries

1. Make sure that flamethrower is off by setting the power switch (10) to the “OFF” position.

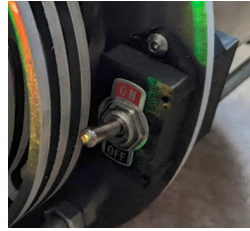

2. Plug the red T-Connector from the batteries into the battery charger charging port. Plug the white JST-XH connector into the battery charger cell balancing port.

3. Select Lithium BATT and press ENTER.



4. Select LiPo Balance CHG AUTO and 6.0A.

Charging the Batteries

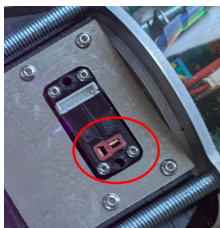

5. Plug the charging cable into the power panel



6. balancing cable into the power panel.



7. Hold ENTER for 2 seconds.



8. Press ENTER again



9. You may need to wait 30 minutes or more for the battery to fully charge. The battery charger will make a high pitched sound, to indicate a full charge. When the battery is fully charged press the "Stop" button.

Product Storage and Maintenance

- Wipe down the tip of the flamethrower with a paper towel to remove carbon buildup.
- Only store the flamethrower when it is cooled to room temperature
- Ensure all gasoline has been removed from the system before storing
- Place the flamethrower in the storage case that was shipped with your order
- Store in a well-ventilated area

Limited Lifetime Warranty

Prometheus Industries warrants to the original purchaser that The Big Boy Flamehrower is free from defects in material and workmanship when the product is initially purchased. This warranty is valid for all purchases of the Big Boy on or after April 2, 2022. This warranty does not apply to a product that has been damaged as a result of improper use. This warranty is void if the product is repaired or modified in any way by anyone other than Prometheus Industries, or by an approved 3rd party. Prometheus Industries will repair the product if it proves to be defective in materials or workmanship. At the choice of Prometheus Industries, a replacement product may be provided instead of repairing a defective product. The sole obligation of Prometheus Industries and your exclusive warranty are limited to such repair or replacement.

To make a claim under the Limited Lifetime Warranty, contact us on our website www.prometheusindustries.co
Please provide proof of date of purchase when making a claim.

Prometheus Industries makes no other warranties concerning the product. In no event shall Prometheus Industries be liable for incidental or consequential damages. Some states do not allow the exclusion or limitation of incidental or consequential damages, so the above limitation or exclusion may not apply.

This warranty gives you specific legal rights, and you may also have other rights which vary from state to state.

FCC COMPLIANCE:

This device complies with part 18 of the FCC Rules. Operation is subject To the following two conditions:
(1) This device may not cause harmful interference, and
(2) this device must accept any interference received, including interference that may cause undesired operation. Changes or modifications not explicitly approved by Prometheus Industries could void the user's authority to operate this equipment.

Note: This equipment has been tested and found to comply with the limits for a Class A miscellaneous device, pursuant to part 18 of the FCC Rules. These limits are designed to provide reasonable protection against harmful interference in an industrial installation. This equipment generates, uses, and can radiate radio frequency energy and, if not used in accordance with the instructions, may cause harmful interference to radio communications. However, there is no guarantee that interference will not occur in a particular system. If this equipment does cause harmful interference to radio or television reception, which can be determined by turning the equipment off and on, the user is encouraged to try to correct the interference by increasing the distance between the equipment and receiver.



www.prometheusindustries.co