

Compressed Air Sprayer

last updated 08/2021

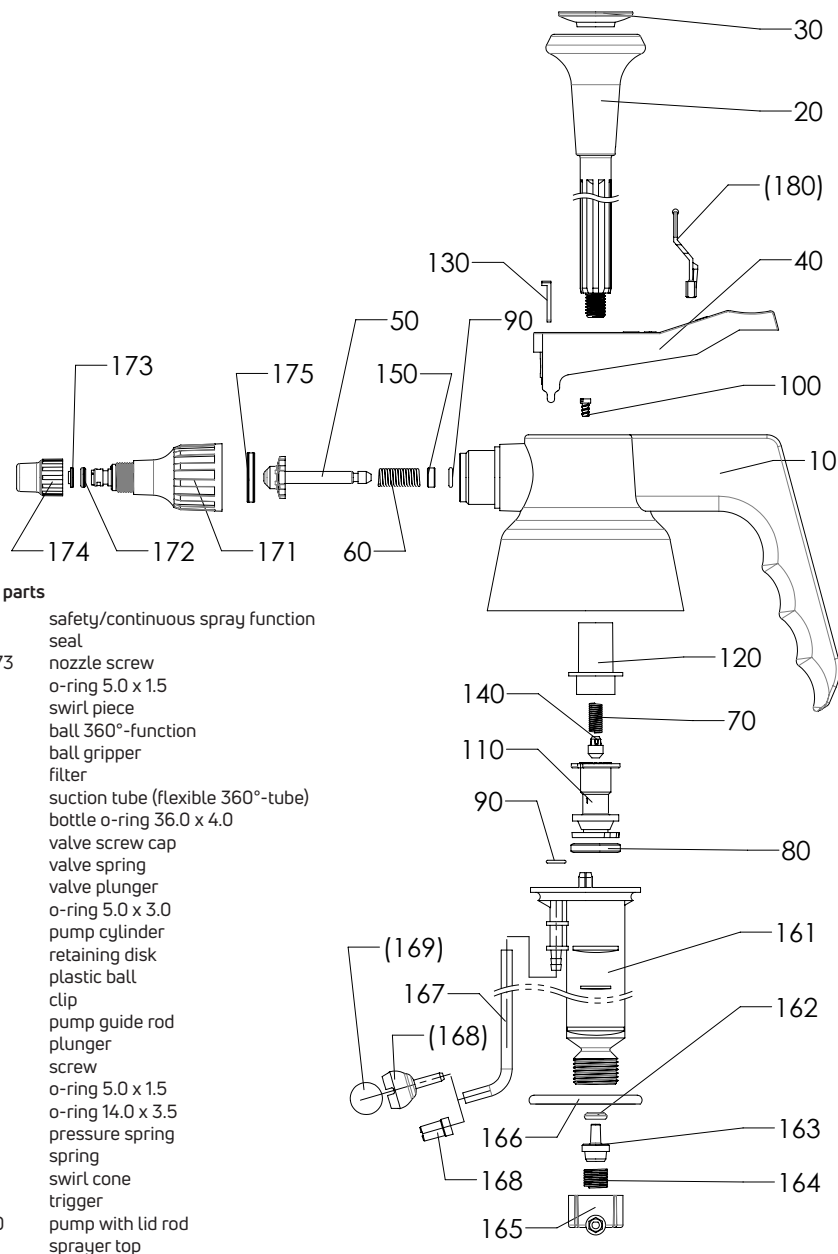

spare parts

(180)	safety/continuous spray function
175	seal
174/173	nozzle screw
172	o-ring 5.0 x 1.5
171	swirl piece
(169)	ball 360°-function
(168)	ball gripper
168	filter
167	suction tube (flexible 360°-tube)
166	bottle o-ring 36.0 x 4.0
165	valve screw cap
164	valve spring
163	valve plunger
162	o-ring 5.0 x 3.0
161	pump cylinder
150	retaining disk
140	plastic ball
130	clip
120	pump guide rod
110	plunger
100	screw
90	o-ring 5.0 x 1.5
80	o-ring 14.0 x 3.5
70	pressure spring
60	spring
50	swirl cone
40	trigger
30/20	pump with lid rod
10	sprayer top

Operating instructions for Compressed Air Sprayers

Congratulations on the acquisition of your new Compressed Air Sprayer. We thank you for your trust in our products. Please read the operating instructions carefully before using the device, and keep them in a safe place. If the device is passed on to a third party, it is imperative that these instructions also be passed on with it.

Preparation

- Check before use that all parts are undamaged and working correctly.
- Unscrew the pump from the tank.
- Fill the canister with liquid up to the "max" level.
- Screw the pump head on and tighten it so that the canister is sealed and airtight (if it is not, it will be impossible for pressure to build up).

Usage

- Pump air into the tank using the piston (around 20 to 30 pump movements).
Important: It is not possible to generate more pressure in the tank than specified. The sprayers are fitted with an **automatic relief valve**.
- Press the spray button to spray. By turning the spray nut, you can set the desired spray pattern (mist ↔ jet).
 - On models with a **safety function**, the safety button must be pulled back before the spray button can be pressed.
 - In the case of models with a **continuous spray function**, the spray lever will lock into place once pressed. Pushing back the lock button will cause the spray lever to jump back to the original position.
- If liquid continues to drip out of the nozzle when releasing the spray button, there is still air in the sprayer. Spray upwards at an incline for around two to three seconds to enable the air to escape. The ability to spray evenly and without any problems is dependent on the use of a clean spray agent. Mix chemicals and water thoroughly prior to filling. Please note the usage instructions of the chemical manufacturer.

After usage

- Once you have finished spraying, unscrew the spray head slowly to allow the pressure to escape.
- Do not pour residues into drains; instead, dispose of them in accordance with the instructions of the manufacturer of the liquid. Then clean the pump by using it to spray clean water or a suitable cleaning agent.

Safety

- Never leave the tank in a pressurised state for long periods of time.
- Do not expose the Compressed Air Sprayer to direct sunlight.
- Do not fill any hot liquids exceeding 30° Celsius.
- Note the safety data sheet of the liquid's manufacturer.
- Never aim the sprayer at people or animals.
- The manufacturer is not liable for damage caused by incorrect usage or unauthorised modifications of the device.

Maintenance and care

- Oil the pump piston from time to time (see symbol on the spray button).
In the case of sprayers with EPDM seals, please only use silicone oil/greases for lubrication.
- Check that the nozzle and sieve at the end of the hose is free of deposits.
Use compressed air to clean the nozzle or sieve if it is blocked.
- If a part is visibly damaged or worn, replace it. Only use original parts.
- Spare parts and sets of seals can be obtained from your supplier or dealer.