

morphyrichards

Hand blender HBCS

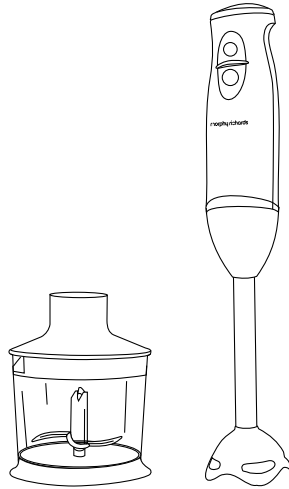

Please read and keep these instructions



getting the best from
your new hand blender...

The hand blender is designed for intermittent use. Do not use non stop for more than 1 minute at a time. Allow to cool down.

Caution: Never use your hand blender in a bowl or saucepan whilst it is cooking.



www.morphyrichards.co.uk
www.morphyrichardsindia.com

Important Safety Instructions

The use of any electrical appliance requires the following of basic common sense safety rules.

Primarily there is danger of injury or death and secondly the danger of damage to the appliance. These are indicated in the text by the following two conventions:

WARNING: Danger to the person!

IMPORTANT: Damage to the appliance!

In addition we offer the following essential safety advice.

Location

- Do not use outdoors.

Mains Lead

- The mains lead should reach without straining the connections.
- Do not let the mains lead hang over the edge of a worktop where a child could reach it.
- Do not let the lead run across an open space e.g. between a low socket and table.
- Do not let the lead run across a cooker or toaster or other hot area which might damage the cable.

Your Safety

- Unplug from outlet before cleaning or removing parts.
- Do not touch moving parts. Keep hands, hair, clothing as well as utensils away from the hand blender blades.
- Don't let rotating blades touch the mains cable.
- **TAKE CARE WHEN HANDLING METAL BLADES AS THEY ARE VERY SHARP.**
- Don't clean the blades under running water while they are in position.
- Make sure the blender is switched off before connecting to or disconnecting from the mains supply.
- Do not use during cooking processes or with boiling liquids

Children

- Do not allow children to use this blender. Children are vulnerable in the kitchen particularly when unsupervised and if appliances are being used or cooking is being carried out.
- Teach children to be aware of danger in the kitchen, warn them of the dangers of reaching up to areas where they cannot see properly or should not be reaching.

Other Safety Considerations

- To protect against fire, electric shock and personal injury do not immerse cord, plug or blender in water or other liquid.
- Do not operate any appliance with a damaged cord or plug or after the appliance malfunctions or has been damaged in any manner.
- Do not use accessories not recommended by the manufacturer as there is the danger of fire, electric shock or personal injury.
- Do not place on or near a hot gas or electric burner or in a heated oven.
- Unplug from outlet when not in use.

Electrical Requirements

- Check that the voltage on the rating plate of your appliance corresponds with your house electricity supply which must be A.C. (Alternating Current).
- If the socket outlets in your home are not suitable for the plug supplied with this appliance, the plug should be removed and the appropriate one fitted.

WARNING: The plug removed from the mains lead, if severed, must be destroyed as a plug with bared flexible cord is hazardous if engaged into a live socket outlet.

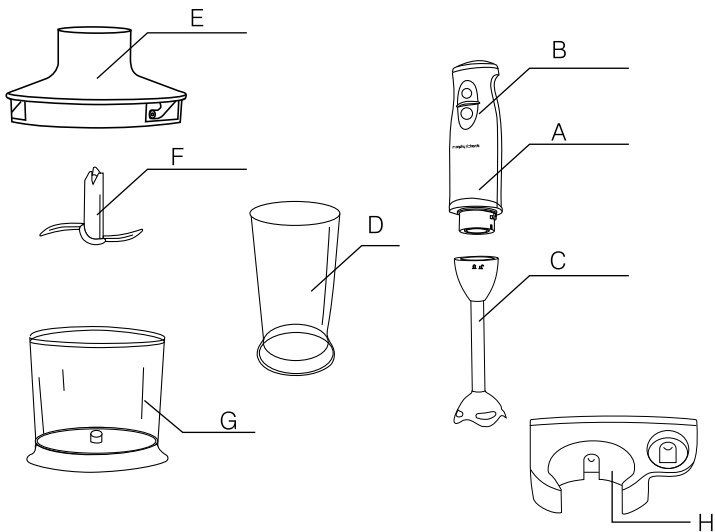

Features

- (A) Main housing
- (B) On/Off switch
- (C) Removable blending attachment
- (D) Measuring beaker
- (E) Chopper gear box
- (F) Chopper blade
- (G) Chopper bowl
- (H) Anti-slip base

Your hand blender is designed to help you prepare everything from soups to chocolate mousse quickly and with minimal effort.

Unpacking Your Hand Blender

Carefully unpack your hand blender, as blades are very sharp.

Assembly

WARNING: Make sure that the hand blender is switched off and unplugged.

1. Clean the blending attachment before using it for the first time with damp cloth.
2. Insert the blending attachment into the main housing with sides aligned and press upwards till you hear a click.
3. The hand blender can now be plugged in and is now ready to use.
4. Place the blending attachment into the food to be blended and press the On/Off switch (B).

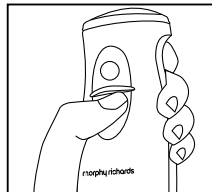
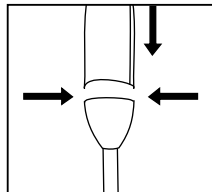

- After use, unplug the blender by pressing the side buttons and pulling the blending attachment down.

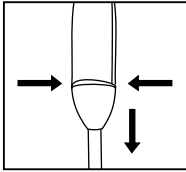

The hand blender can be used with a beaker or saucepan.

Your hand blender is designed for intermittent use. Do not use non-stop for more than 1 minute. Allow to cool down for approximately 1 minute before further use.

Mini chopper

The mini chopper can be used for meat, hard cheese, nuts, herbs, boiled eggs, dry bread etc.

- Clean the mini chopper before using for the first time **CAUTION : THE BLADES ARE EXTREMELY SHARP.**
- Fit the blade into the chopper bowl.

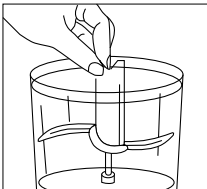

- Add food and fit the lid onto the mini chopper.

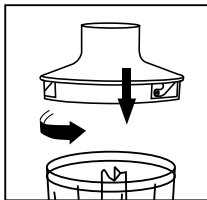

- Place the main housing onto the top of the lid of the chopper with sides aligned, press it down till you hear a click, the main housing is now locked with chopper and is ready to use.

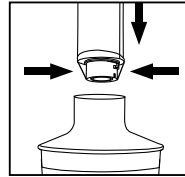

Plug in the blender and press the on/off switch. Keeping the blender firmly on the work surface.

Note your hand blender is not suitable for grinding coffee beans.

Below, there are a few guidelines, these may vary according to the quantity and the consistency of the food.

Food	Capacity	Preparation	Approx. Time
Veal	200gm	Dice approx 2 cm	20-30 secs.
Pork	200gm	Dice approx 2 cm	20-30 secs.
Hard cheese	100gm	Dice approx 1 cm	30-40 secs.
Almonds	150gm	None	10-20 secs.
Hard boiled eggs	2 eggs	Cut into halves	3-5 secs.
Onion	100gm	Cut into quarters	3-6 secs.
Parsley	bunch	Remove stalks	3-5 secs.
Carrots	150 gm	Slice	5-10 secs.
Dry bread	1 slice	Cut into quarters	10-20 secs.

Using the hand blender

Using the hand blender for the first time

WARNING: THE BLADE IS VERY SHARP. TAKE GREAT CARE WHEN HANDLING THIS HAND BLENDER AND ALWAYS UNPLUG FROM THE MAINS SUPPLY BEFORE CLEANING.

- Fill a jug with warm, soapy water then immerse the blade. Plug into a mains wall socket and switch on.
- Operate the hand blender for a few seconds by pressing the **Low speed button**.
- Remove the plug from the mains socket and dry the hand blender thoroughly.

Using the hand blender for dry ingredients

- Place the ingredients (such as breadcrumbs, nuts, mushrooms etc.) into the measuring breaker (or a similar container tall, narrow containers achieve the best results).
- Plug into a mains wall socket and switch on.
- Hold the blender blade above the ingredients, press either the Low speed or High speed button and push the blade into the ingredients until desired consistency is achieved.
- Remove the plug from the mains socket.

Using the hand blender for liquids

- Using a suitable jug or bowl, immerse the blade into the liquid.
- Plug into a mains wall socket and switch on.
- Press either the **Low speed or High speed button as required (always start and stop the blender while the blades are below the surface of the liquid to prevent splashing)**.
Remove the plug from the mains socket.

Cleaning

Before cleaning and maintenance, switch the appliance off and unplug it.

1. Remove the blending attachment.

2. Clean the blending attachment and measuring beaker in warm soapy water and dry thoroughly.
3. Clean the main housing with a damp cloth and dry thoroughly.

Hints for Blending

When processing food with strong color (e.g. carrots) the plastic parts of the appliance may become discolored. Use cooking oil to clean any discolored parts.

Trouble Shooting

Check the plug is in its socket and the switch is in the 'on' position?

Is the plug itself or the socket faulty - check this by plugging in another appliance?

Check the following for a possible cause.

- **Appliance gets very hot.**

Blender has been used for too long continuously.
Leave the appliance to cool.

- **Appliance not working.**

The removable blender attachment has not been fitted correctly.

Unscrew the attachment and replace as described in 'assembly'.

Technical Data

- Power Supply : AC 230V~50Hz
- Wattage : 300W

Morphy Richards products are intended for household use only

Morphy Richards has a policy of continuous improvement in product quality and design. The Company, therefore, reserves the right to change the specification of its models at any time.

morphy richards

Morphy Richards Ltd, Mexborough,
South Yorkshire, England, S64 8AJ