

IGUANA

PRICING MENU

- Overall chassis length = 367mm (405mm with bumpers)
- Skid eye-eye Mounting Distance = 38mm (Axial / Element standard)
- Frame Rail Width (Inside) = 67mm
- **ABDOMEN** skid is completely smooth on the underbelly and incorporates a newly-designed transfer case with 30% OD
- Incorporates a rear carrier bearing to keep your driveshaft out of the rocks
- 10° Angled skid, excellent breakover angle, un-matched rear link/ driveshaft clearance
- Brand new one piece stainless steel and aluminum links available
- F10-specific, one-piece, high-clearance tierod allows for a smooth 60°+ steering angle
- Designed with SORRCA requirements in mind

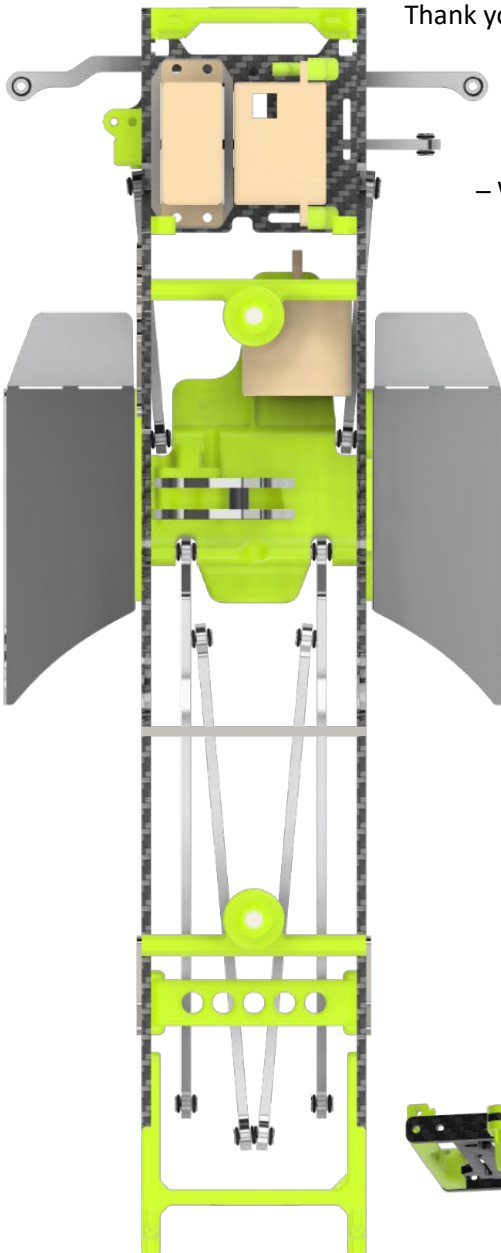

Thank you for your interest in the new **IGUANA LCG Chassis System**. I have no doubt that this animal will continue to impress each trip out to the rocks or trail. The following is a direct result of over two years of chassis-specific development. Enjoy!

– Will Akers, Designer & Owner

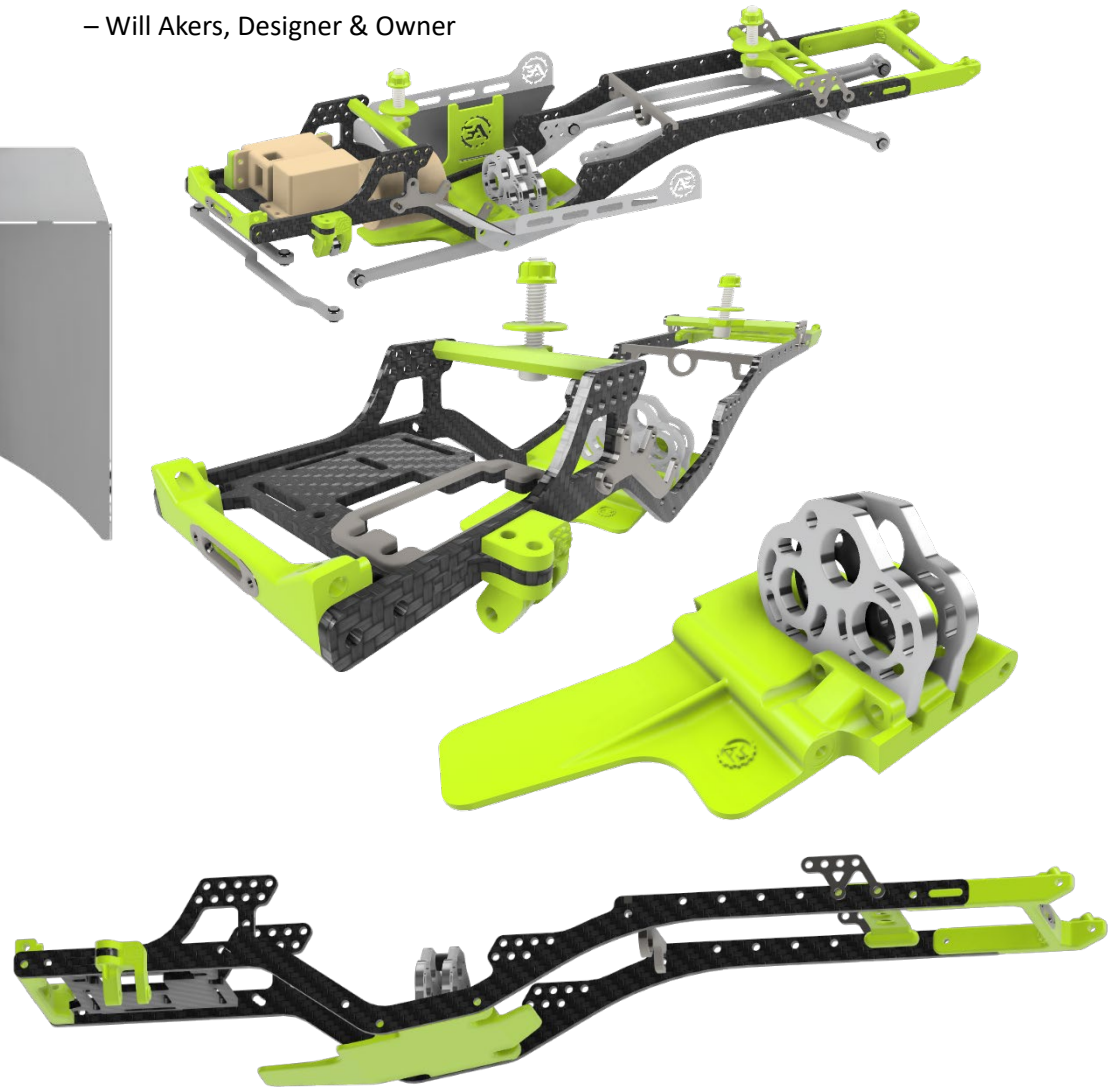

LEVEL 1 - *ECO IGUANA*

B.Y.O. SKID & DRIVETRAIN

Component Description	Material	QTY.	Option Retail
IGUANA Frame Rails	3mm 2x2 Twill Weave Carbon Fiber	2	
Side Holster Micro Winch Mount	1.6mm Gr5 Titanium	1	
Carrier Bearing Support Bracket	3.2mm Gr5 Titanium	1	
Rear Shock Mounts	1.6mm Gr5 Titanium	2	
Rear Support Crossmember	AE 3D Printed PETG	1	
67mm Unicorn Strut	AE 3D Printed PETG	1	
73mm Unicorn Strut	AE 3D Printed PETG	1	\$149.99
20mm Unicorn Body Washer	AE 3D Printed PETG	2	
M6 x 35mm Nylon Bolts, Nuts, Washers	Black Nylon	2	
M3 x 8mm Screws	316 SS	6	
M3 x 10mm Screws	316 SS	4	
M3 Nylon-locking Nuts	316 SS	2	
		25	

RUNNING TOTAL = \$149.99



LEVEL 2 - *ATTACK IGUANA*

ENABLES CMS & SERVO WINCH OPTIONS

Component Description	Material	QTY.	Option Retail
CMS Plate	3mm 2x2 Twill Weave Carbon Fiber	1	\$49.99
Servo Brace	1.6mm Gr5 Titanium	1	
Panhard Bracket	AE 3D Printed PETG	1	
Full-Size Servo Winch Tabs	AE 3D Printed PETG	2	
Micro Servo Winch Tabs	AE 3D Printed PETG	2	
M2 x 4mm Screws	316 SS	2	
M3 x 6mm Screws	316 SS	6	
M3 x 8mm Screws	316 SS	2	
M3 x 10mm Screws	316 SS	8	
M3 x 16mm Screw	316 SS	1	
M3 Nylon-locking Nuts	316 SS	6	
		32	

RUNNING TOTAL = \$199.98



LEVEL 3 - *ARMORED IGUANA*

"BLANK SLATE" SKID, BUMPERS & COMP SLIDERS

Component Description	Material	QTY.	Option Retail
AE Blank Slate Skid	AE 3D Printed PETG	1	\$79.99
Front Bumper	AE 3D Printed PETG	1	
Rear Bumper	AE 3D Printed PETG	1	
Winch Fairleads	1.6mm Gr5 Titanium	2	
AE Boatside Rock Sliders	0.6mm T3 Aluminum	2	
2mm Slider Spacers	AE 3D Printed PETG	2	
2mm Slider Spacers with Battery Strap Mount	AE 3D Printed PETG	2	
M1.4 x 5mm Screws	Black Oxide	4	
M2 x 4mm Screws	316 SS	4	
M3 x 6mm Screws	316 SS	2	
M3 x 10mm Screws	316 SS	2	
M3 x 20mm Screws	316 SS	2	
M3 x 25mm Screws	316 SS	2	
		27	

RUNNING TOTAL = \$279.97

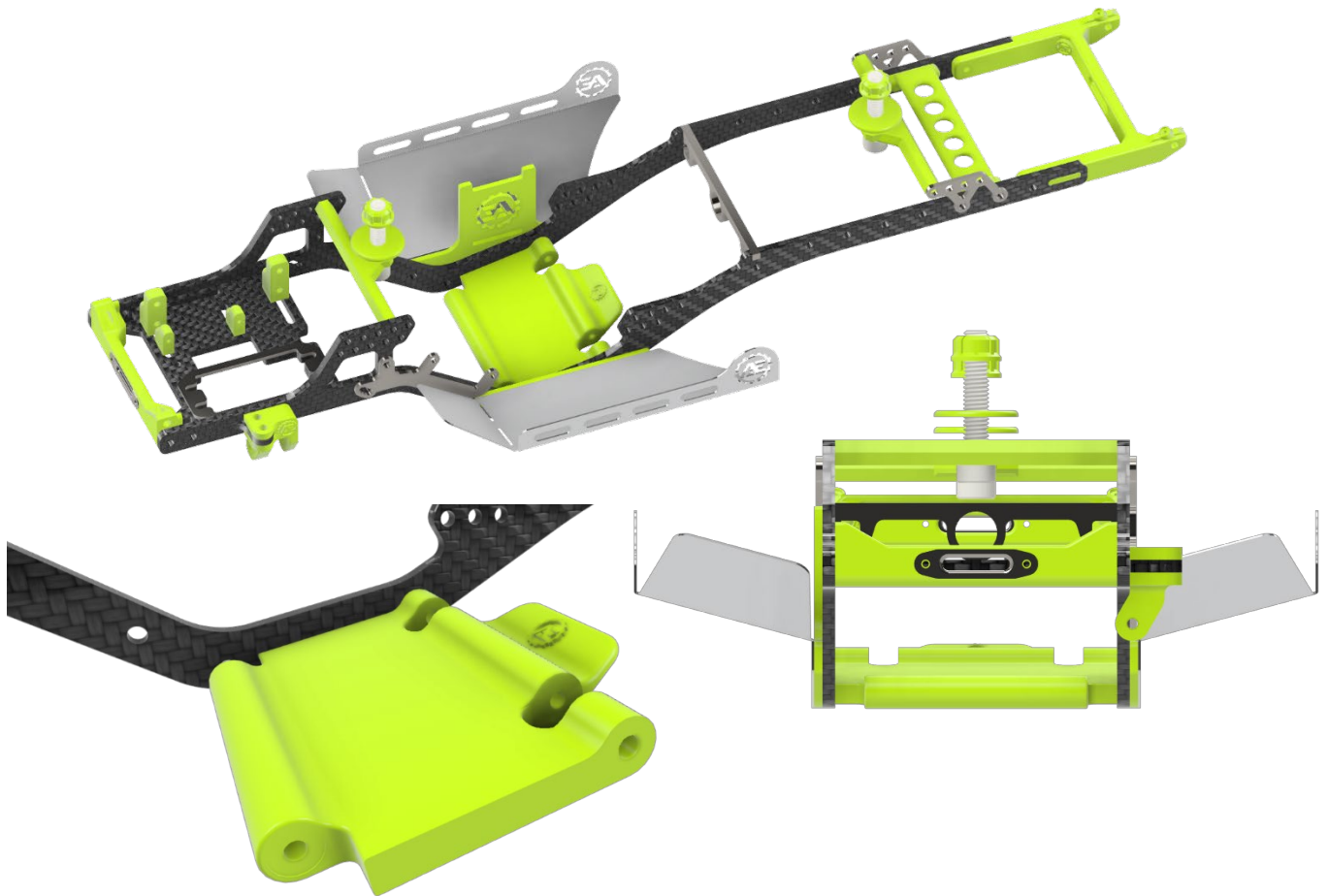

LEVEL 4 - *INDOMINUS IGUANA*

F10 LINK SET & "ABDOMEN" UPGRADE

Component Description	Material	QTY.	Option Retail
F10 Panhard (99mm)	.125" 316 SS	1	
F10 Draglink (93mm)	.125" 316 SS	1	
F10 Tierod (147mm)	.125" 316 SS	1	
F10 Front/Lower Radius Arm (83mm)	.125" 316 SS	1	
F10 Front/Lower Control Arm (83mm)	.125" 316 SS	1	
F10 Rear/Upper Links (163mm)	.125" 7075 Aluminum	2	
F10 Rear/Lower Links (180mm)	.125" 7075 Aluminum	2	
Incision SS Rod End Balls	316 SS	20	
1.5mm x 3.5mm ID Buna-N O-Rings	Nitrile	40	
ABDOMEN Skid	AE 3D Printed PETG	1	
ABDOMEN Transfer Case Front Plate	.125" 7075 Aluminum	1	
ABDOMEN Transfer Case Rear Plate	.125" 7075 Aluminum	1	
ABDOMEN Transfer Case 3mm x 6.5mm x 7mm Spacer	AE 3D Printed PETG	1	
5mmx10mmx4mm Flanged Bearings	Fast Eddy Sealed Bearing	6	
ABDOMEN Transfercase Gear Set (30% OD)	Case-Hardened Steel	1	
TGH Forward Motor Mount (FMM) E.B.R. Edition	Aluminum, Black	1	
Spur Gear Slipper Eliminator Front	1.0mm Gr5 Titanium	1	
Spur Gear Slipper Eliminator Back	1.6mm Gr5 Titanium	1	
Incision 56T Spur Gear (P/N: INCIRC00402)	Plastic	1	
3/4" Rubber Bands	Rubber	4	
M3 x 12mm Screws	316 SS	2	
M3 x 14mm Screws	316 SS	1	
M3 x 20mm Screws	316 SS	2	
M3 Nylon-locking Nuts	316 SS	2	
		95	\$289.99

RUNNING TOTAL = \$569.96

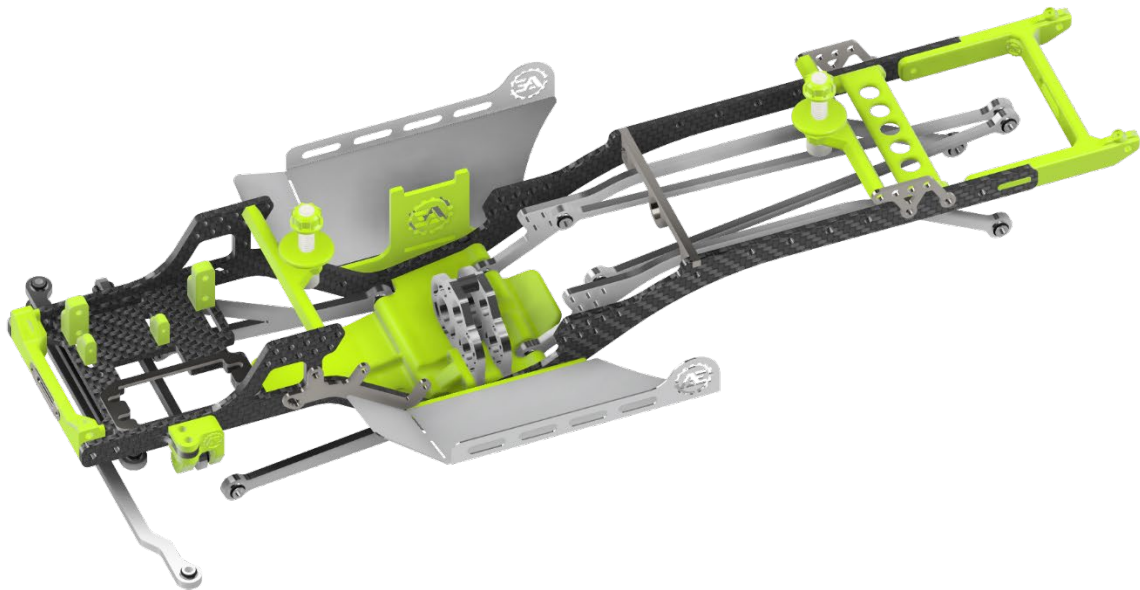

F10 PACKAGE

Component Description	Material	QTY.	Option Retail
VP F10 Nylon Portal Axle, Front	Plastic, Black	1	\$424.96
VP F10 Nylon Portal Axle, Rear	Plastic, Black	1	
VP F10 Brass Portal Knuckle Weights, Front (Pair)	Brass	1	
VP F10 Brass Portal Knuckle Weights, Rear (Pair)	Brass	1	
		4	

RUNNING TOTAL = \$994.92

DLUX FAB PARTS PACKAGE

Component Description	Material	QTY.	Option Retail
Dlux Fab Cut-to-Length Driveshaft	Hardened Steel	2	\$236.00
Dlux Fab 5mm U-Joints	Hardened Steel	4	
Dlux Fab 112mm "Long" Shocks (Pair)	Aluminum	1	
Dlux Fab 80mm "Ultra Short" Shocks (Pair)	Aluminum	1	
Dlux Fab Offset Shock Caps + Short Rod Ends (Pair)	Aluminum	2	
Dlux Fab Wraith/Universal Sway Bar	Carbon Fiber	1	
DLUX Fab parts are discounted 10% when bundled together! (Nearly \$30 savings)		11	

RUNNING TOTAL = \$1,230.92

MAKE IT "TURN KEY"

FULLY ASSEMBLED BY AKERS ENGINEERING

Component Description	Material	QTY.	Option Retail
Assemble Chassis and Components	(Assemble Chassis)	1	\$100.00
Bend Aluminum Sliders as Designed			
Bend Aluminum Bucket Seats as Designed (If Applicable)			
Assemble Links	(Assemble Axles)	1	\$50.00
Assemble ABDOMEN Package (FMM & T-Case)			
Assemble Front F10 Axle	(Assemble Dlux Driveshafts, Shocks, Swaybar)	1	\$100.00
Assemble Rear F10 Axle			
Cut Driveshafts and Intermediate Shafts to Length			
Assemble Shocks (Per Erik Dye's 2019 Method)			
Use Blue Loctite Strategically			
Cut Swaybar to Length and Install		3	
*Lead times will vary based on schedule			

RUNNING TOTAL = \$1,480.92

