

PUNTELLI TELESCOPICI

ADJUSTABLE PROPS FOR FLOOR

Puntelli Telescopici

Le Officine Villalta offrono diverse versioni di puntelli, in modo da risolvere qualsiasi esigenza di portata si presenti, fino a mt. 5,50 di altezza. Quindi, data l'importanza che questo articolo ricopre nel settore dell'edilizia, le Officine Villalta hanno sviluppato 5 classi di puntelli regolabili in base alla normativa europea, che permettono di armare le gettate di solette e soffitti qualunque sia il sistema usato (travi rompitratta, legname, casseforme, ecc...) offrendo millimetriche possibilità di regolazione tra le posizioni chiuse e completamente aperte e diversi carichi di utilizzo.

Adjustable props for floor

Officine Villalta fabricates different types of props to solve every requirement of loading capacity up to 5,50 mt height. Considering the importance of this product in the building industry Officine Villalta developed 5 classes of adjustable props according to the European Norm that permit to reinforce the concrete layer of slabs and ceilings whichever will be the adopted system (inter-tie girder, timber, formworks, etc...), offering millimetric possibilities of adjustment between closed and fully open positions and different using loads.

Officine Villalta
Ponteggi Fav3 | Puntelli | Tubo & Giunto



Puntelli italiani

Italian props

Tutti i puntelli prodotti dalle Officine Villalta presentano fondamentali caratteristiche tecniche, quali:

- maschio filettato saldato sul tubo esterno realizzato con processo di rullatura che conferisce massima precisione geometrica del pezzo e assoluta stabilità unitamente ad una migliore finitura senza estrarre il materiale;
- tubo interno forato ogni 100 mm per la regolazione in altezza;
- sistema di regolazione millimetrica a manicotto e ghiera in ghisa sferoidale;
- gancio di sicurezza in acciaio ad alta resistenza per il collegamento tra tubo interno ed esterno;
- rondella di scorrimento e protezione nella versione manicotto;
- basetta inferiore per la miglior ripartizione del carico a terra e con diversa versione dell'appoggio superiore (basetta, croce, forca) per le diverse necessità;
- sganciatore per permettere l'abbassamento rapido del puntello dalla posizione di lavoro di 5 mm senza danneggiarlo.

Props are fabricated by Officine Villalta according to the basic technical specifications, as:

- threaded screw tap welded on the external tube realized by a rolling process to grant the highest geometric precision of the piece and absolute stability with a better finishing without extracting the material;
- internal pipe perforated each 100 mm for height adjustment;
- millimetric adjustment by cover thread ductile cast iron collar nut;
- steel safety pin high resistant to join the external and internal tube;
- sliding and protecting washer for cover thread version;
- base plate for the best distribution of the load on earth and with a different upper support system base plate, cross-head, fork-head) according to the necessity;
- quick release device with single hammer blow for the automatic lowering of props by 5 mm without damaging the collar nut.

mod.	50/100	70/120	100/170	160/290	180/320	200/360	220/400	250/440	260/480	320/500
cm	KG	KG	KG	KG	KG	KG	KG	KG	KG	KG
500										400
480									520	520
440								700	690	750
420								810	820	980
400							758	900	900	1100
380							890	950	1050	1250
360						801	980	1010	1200	1480
340						1091	1150	1190	1320	1600
320					870	1215	1230	1300	1400	
300					1071	1280	1300	1420	1480	
290				1010	1190	1385	1450	1500	1600	
270				1080	1346	1509	1630	1580	1700	
250				1190	1540	1640	1700	1700		
230				1350	1660	1750	1750			
220				1430	1740	1764	1800			
200				1620	1785	1800				
180				1765	1800					
170			1500	1800						
160			1570	1800						
140			1650							
120		1480	1800							
100	1400	1600	1800							
90	1620	1800								
70	1700	1800								
60	1800									
50	1800									

Tubo interno
Inner pipe

ø 48,3
ø 48,3

Tubo esterno
Outer pipe

ø 56
ø 56

Gancio
Pin

ø 14
ø 14



I valori di carico ammessi per la sicurezza nel lavoro, riferiti ai puntelli standard, sono calcolati secondo un coefficiente di sicurezza e si ottengono con un perfetto carico assiale. Il fabbricante declina ogni responsabilità per qualsiasi danno occorso dovuto ad un carico sbagliato, al non rispetto delle condizioni di verticalità e assialità del carico o ad un uso improprio del puntello.

The allowable loads of standard props, for safety working, are calculated with the safety factor, and obtained with a perfect axial load. The producer declines all responsibilities for any damage occurred for misloading improper use of the props.

T.P. (Tira & Spingi) Push-Pull Props

I puntelli T.P. trovano un ottimo utilizzo nella prefabbricazione, infatti garantisce la stabilità delle pareti prefabbricate, permettendo così all'operatore di svolgere tutte le operazioni necessarie al loro definitivo bloccaggio, il tutto con la massima sicurezza.

Push/pull props find a very rational utilization in the field of the pre-fabrication, as they enable perfect steadiness of the pre-casted walls allowing thus the safe and economical assembling and locking operations.

Estensione (cm) Extension (cm)	T.P. 180/320			T.P. 200/360			T.P. 220/400			T.P. 250/400		
	Forza di compressione Compression force Ph (KG)	Forza di trazione Traction force Pa (KG)	Pz (KG)	Forza di compressione Compression force Ph (KG)	Forza di trazione Traction force Pa (KG)	Pz (KG)	Forza di compressione Compression force Ph (KG)	Forza di trazione Traction force Pa (KG)	Pz (KG)	Forza di compressione Compression force Ph (KG)	Forza di trazione Traction force Pa (KG)	Pz (KG)
440										540	765	1785
430										587	831	1785
420										617	872	1785
410										671	948	1785
400							601	851	1785	681	963	1785
390							627	887	1785	721	1020	1785
380							660	933	1785	803	1137	1785
370				563	796	1785	721	1020	1785	861	1218	1785
360				671	949	1785	796	1127	1785	883	1249	1785
350				765	1081	1785	822	1162	1785	915	1295	1785
340				812	1148	1785	869	1229	1785	944	1336	1785
330				858	1214	1785	930	1315	1785	981	1387	1785
320				880	1244	1785	967	1366	1785	1012	1433	1785
310				905	1280	1785	1002	1417	1785	1059	1499	1785
300	981	1387	1785	714	1010	1785	1071	1514	1785	1092	1545	1785
290	1017	1438	1785	740	1046	1785	1110	1570	1785	1150	1626	1785
280	1068	1510	1785	761	1076	1785	1150	1626	1785	1254	1774	1785
270	1118	1581	1785	789	1117	1785	1195	1691	1785	1261	1785	1785
260	1158	1637	1785	840	1188	1785	1254	1774	1785	1261	1785	1785
250	1219	1724	1785	920	1301	1785	1261	1785	1785			
240	1237	1749	1785	952	1346	1785	1261	1785	1785			
230	1247	1765	1785	1006	1423	1785						
220	1262	1785	1785	1066	1508	1785						
210	1262	1785	1785	1139	1612	1785						
200	1267	1785	1785	1226	1734	1785						
190	1267	1785	1785									

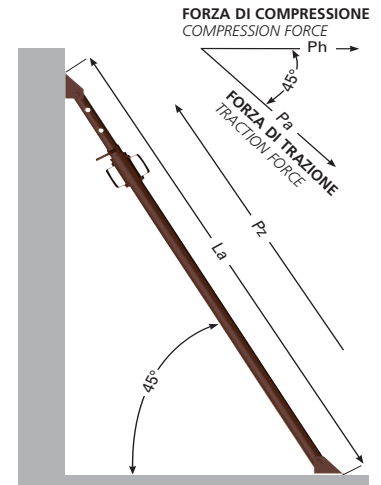

Puntelli omologati DIN EN 1065 Classe A Props homologated according to DIN EN 1065 Class A

mod. (cm)	A25 KN	A30 KN	A35 KN	A40 KN
400				7,50
390				7,89
380				8,31
370				8,77
360				9,26
350			8,57	9,80
340			9,08	10,38
330			9,64	11,02
320			10,25	11,72
310			10,93	12,49
300		10,00	11,67	13,33
290		10,70	12,49	14,27
280		11,48	13,39	15,31
270		12,35	14,40	16,46
260		13,31	15,53	17,75
250	12,00	14,40	16,80	19,20
240	13,02	15,63	18,23	20,83
230	14,18	17,01	19,85	22,68
220	15,50	18,60	21,69	
210	17,01	20,41	23,81	
200	18,75	22,50	25,88	
190	20,78	24,93		
180	23,15	25,88		
170	25,88			
160	25,88			
150	25,88			

CLASSE A HPE ghiera esterna o manicotto

Calcolati secondo la classe, l'altezza e la massima estensione in base alla seguente equazione:

$$\text{Carico ammissibile} = 30 \frac{\max I}{P} \text{ in kN fino a } 25,9 \text{ kN}$$

CLASS A HPE open thread or sleeve cover thread
Calculated according to the class and length at the maximum extension in accordance with the following equation:

$$\text{Allowable load} = 30 \frac{\max I}{P} \text{ kN to } 25,9 \text{ kN}$$

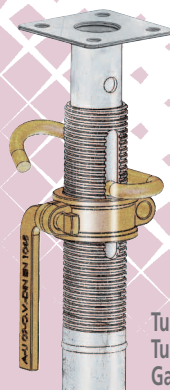
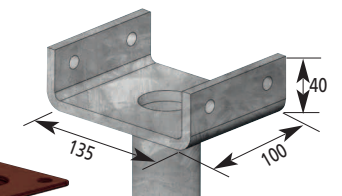
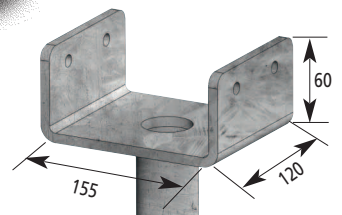

Tubo interno $\varnothing 48,3$ Inner pipe $\varnothing 48,3$
Tubo esterno $\varnothing 57$ Outer pipe $\varnothing 57$
Gancio $\varnothing 14$ Pin $\varnothing 14$

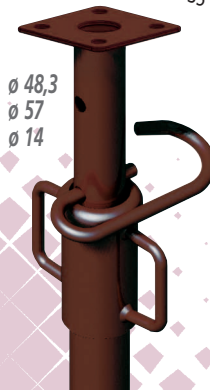

Tubo interno $\varnothing 48,3$ Inner pipe $\varnothing 48,3$
Tubo esterno $\varnothing 60$ Outer pipe $\varnothing 60$
Gancio $\varnothing 14$ Pin $\varnothing 14$

1 kN=102 Kg

Puntelli omologati DIN EN 1065 Classe B

Props homologated according to DIN EN 1065 Class B

mod. (cm)	B30 KN	B35 KN	B40 KN	B45 KN
450				8,89
440				9,30
430				9,73
420				10,20
410				10,71
400			10,00	11,25
390			10,52	11,83
380			11,08	12,47
370			11,69	13,15
360			12,35	13,89
350		11,43	13,06	14,69
340		12,11	13,84	15,57
330		12,86	14,69	16,53
320		13,67	15,63	17,58
310		14,57	16,65	18,73
300	13,33	15,56	17,78	20,00
290	14,27	16,65	19,02	21,40
280	15,31	17,86	20,41	22,96
270	16,46	19,20	21,95	24,69
260	17,75	20,71	23,67	26,63
250	19,20	22,40	25,60	28,80
240	20,83	24,31	27,78	30,00
230	22,68	26,47	30,00	
220	24,79	28,93		
210	27,21	30,00		
200	30,00	30,00		
190	30,00			
180	30,00			

1 kN=102 Kg

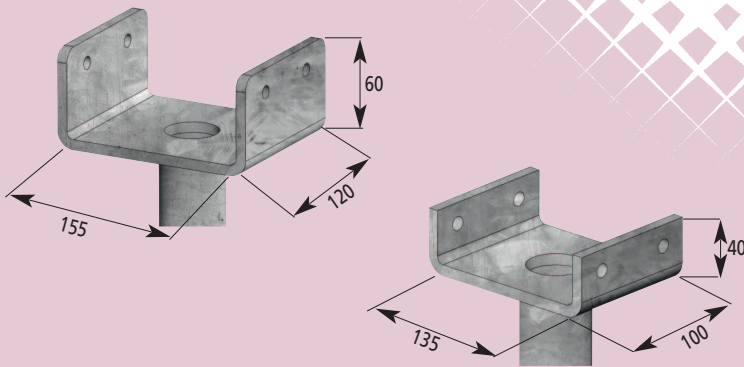

CLASSE B HPE ghiera esterna o manicotto

Calcolati secondo la classe, l'altezza e la massima estensione in base alla seguente equazione:

$$\text{Carico ammissibile} = 40 \frac{\text{max } l}{l^2} \text{ in kN fino a 30 kN}$$

CLASS B HPE open thread or sleeve cover thread

Calculated according to the class and length at the maximum extension in accordance with the following equation:

$$\text{Allowable load} = 40 \frac{\text{max } l}{l^2} \text{ kN to 30 kN}$$

Tubo interno ø 48,3 Inner pipe ø 48,3
 Tubo esterno ø 57 Outer pipe ø 57
 Gancio ø 14 Pin ø 14

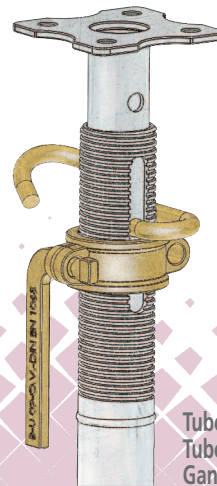
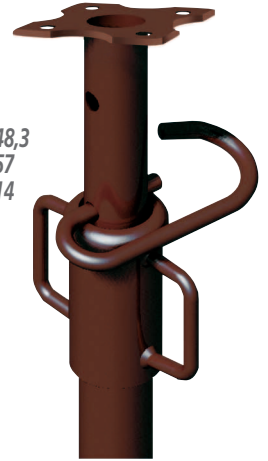

Tubo interno ø 48,3 Inner pipe ø 48,3
 Tubo esterno ø 60 Outer pipe ø 60
 Gancio ø 14 Pin ø 14

Puntelli versione T.P. Tipo B

Push / Pull prop Class B

	Apertura min	Opening max
T.P.178/300	178	300
T.P. 203/350	203	350
T.P.235/400	235	400
T.P.260/450	260	450

Tubo interno ø 48,3 Inner pipe ø 48,3
 Tubo esterno ø 57 / ø 60 Over pipe ø 57 / ø 60
 Gancio ø 14 Pin ø 14



Puntelli omologati DIN EN 1065 Classe C

Props homologated according to DIN EN 1065 Class C

CLASSE C HPE ghiera esterna

Calcolati secondo la classe, l'altezza e una qualsiasi estensione in base alla seguente equazione:

$$\text{Carico ammissibile} = \frac{60 \max I}{l^2} \text{ in kN fino a } 35 \text{ kN}$$

CLASS C HPE open thread

Calculated according to the class and length at any extension in accordance with the following equation:

$$\text{Allowable load} = \frac{60 \max I}{l^2} \text{ kN to } 35 \text{ kN}$$

mod. (cm)	C/E30 KN	C/D35 KN	C40 KN	C45 KN	C55 KN
550					10,91
540					11,32
530					11,75
520					12,20
510					12,69
500					13,20
490					13,74
480					14,32
470					14,94
460					15,60
450				13,33	16,30
440				13,95	17,05
430				14,60	17,85
420				15,31	18,71
410				16,06	19,63
400			15,00	16,87	20,62
390			15,78	17,75	21,70
380			16,62	18,70	22,85
370			17,53	19,72	24,11
360			18,52	20,83	25,46
350		20,00	19,59	22,04	26,94
340		20,00	20,76	23,36	28,55
330		20,00	22,04	24,79	30,30
320		20,51	23,44	26,37	32,23
310		21,85	24,97	28,10	34,34
300	30,00	23,33	26,67	30,00	35,00
290	30,00	24,97	28,54	32,10	
280	30,00	26,79	30,61	34,44	
270	30,00	28,81	32,92	35,00	
260	30,00	31,07	35,00	35,00	
250	30,00	33,60	35,00	35,00	
240	31,25	35,00	35,00		
230	34,03	35,00	35,00		
220	35,00	35,00			
210	35,00	35,00			
200	35,00	35,00			
190	35,00				
180	35,00				

Tubo interno ø 63,5 Inner pipe ø 63,5
 Tubo esterno ø 76 Outer pipe ø 76
 Gancio ø 16 Pin ø 16

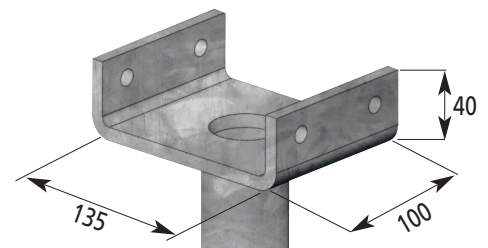
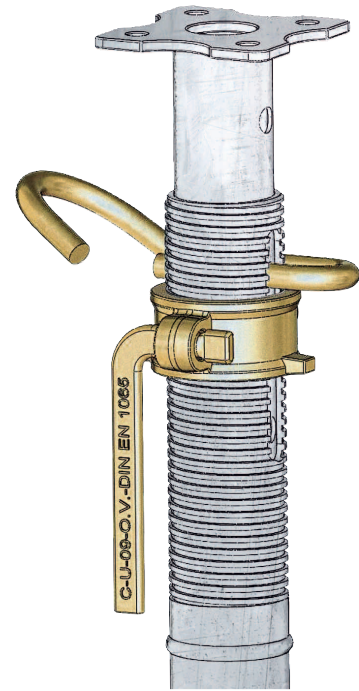

1 kN=102 Kg

Sganciatore optional per tutti i puntelli ø 48-60-76

Quick release ø 48-60-76 optional for all props

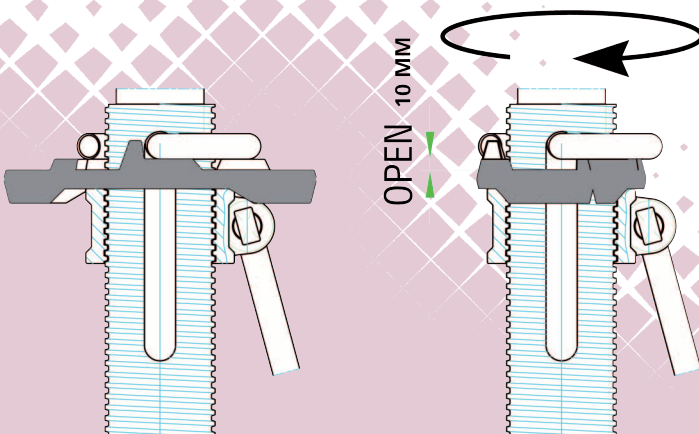

Puntelli omologati DIN EN 1065 Classe D

Props homologated according to DIN EN 1065 Class D

mod. cm	B/D30 KN	C/D35 KN	D40 KN	D45 KN	D50 KN
500					20,00
450				20,00	20,00
400			20,00	20,00	20,00
350		20,00	20,00	20,00	20,00
340		20,00	20,00	20,00	20,00
330		20,00	20,00	20,00	20,00
320		20,51	20,00	20,00	20,00
310		21,85	20,00	20,00	20,00
300	20,00	23,33	20,00	20,00	20,00
290	20,00	24,97	20,00	20,00	20,00
280	20,00	26,79	20,00	20,00	20,00
270	20,00	28,81	20,00	20,00	
260	20,00	31,07	20,00	20,00	
250	20,00	33,60	20,00		
240	20,83	35,00	20,00		
230	22,68	35,00	20,00		
220	24,79	35,00			
210	27,21	35,00			
200	30,00	35,00			
190	30,00				
180	30,00				

1 kN=102 Kg

CLASSE D HPE ghiera esterna

I puntelli Classe D con ghiera esterna HPE hanno sempre la stessa portata - esattamente uguale a prescindere dall'altezza di estrazione:

carico ammissibile: 20 KN come previsto dalla normativa europea EN 1065 Classe D.

$ZulF_D = 20 \text{ kN}$

CLASS D HPE open thread

Props Class D with open thread HPE have the same load at each extension height:

Allowable load:
20 KN according to the EURO NORM EN 1065 Class D.

$ZulF_D = 20 \text{ kN}$

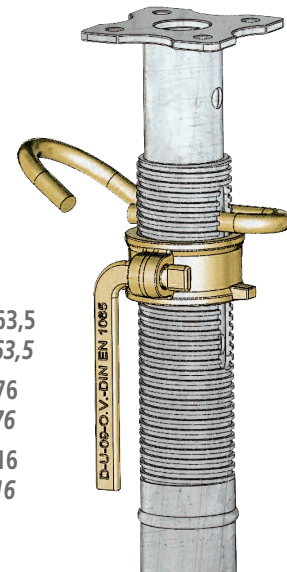

Tubo interno $\varnothing 48/63,5$
Inner pipe $\varnothing 48/63,5$
Tubo esterno $\varnothing 60/76$
Outer pipe $\varnothing 60/76$
Gancio $\varnothing 14/16$
Pin $\varnothing 14/16$

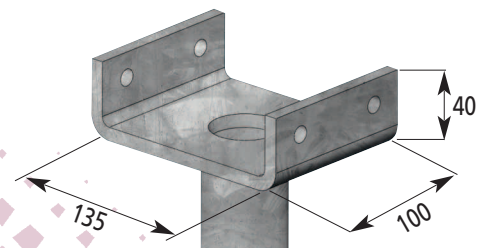

Puntello T.P. doppio braccio

Push / Pull prop double arm

Puntello doppio braccio con manicotto

G400 180/320 • 80/110

Prop double-arm sleeve cover thread

G400 180/320 • 80/110

Tubo interno $\varnothing 48,3$ Tubo esterno $\varnothing 57$ Gancio $\varnothing 14$
Inner pipe $\varnothing 48,3$ Outer pipe $\varnothing 57$ Pin $\varnothing 14$

	Apertura min	Opening max
Braccio inferiore Lower arm	80	110
Braccio superiore Upper arm	180	320

Puntello doppio braccio HTP ghiera esterna

G600 317/570 • 170/300

Prop double-arm HTP open thread

G600 317/570 • 170/300

Tubo interno inferiore $\varnothing 48,3$ Tubo esterno inferiore $\varnothing 60$ Gancio $\varnothing 14$
Lower inner pipe $\varnothing 48,3$ Lower outer pipe $\varnothing 60$ Pin $\varnothing 14$
Tubo interno superiore $\varnothing 63,5$ Tubo esterno superiore $\varnothing 76$ Gancio $\varnothing 16$
Upper inner pipe $\varnothing 63,5$ Upper outer pipe $\varnothing 76$ Pin $\varnothing 16$

	Apertura min	Opening max
Braccio inferiore Lower arm	170	300
Braccio superiore Upper arm	317	570



Puntelli omologati DIN EN 1065 Classe E

Props homologated according to DIN EN 1065 Class E

DIN EN 1065 Classe E

Puntelli telescopici classe E con ghiera esterna HPE.
Avente portata calcolata secondo equazione indicata
dalla normativa

$$\text{Zul } F_c = 60 \times \frac{\text{max } l}{l^2} \quad \text{in kN, fino 35 kN}$$

$$\text{Zul } F_e = 30 \text{ kN}$$

DIN EN 1065 Class E

Adjustable telescopic steel props for the class E bzw. E
with exposed thread.
Calculated according to the class and the length at the
maximum extension in accordance with the following
equation.

$$\text{Zul } F_c = 60 \times \frac{\text{max } l}{l^2} \quad \text{in kN, to 35 kN}$$

$$\text{Zul } F_e = 30 \text{ kN}$$

mod. (cm)	E 25 KN	C/E 30 KN	E 35 KN	E 40 KN	E 45 KN
450					30,00
440					30,00
430					30,00
420					30,00
410					30,00
400				30,00	30,00
390				30,00	30,00
380				30,00	30,00
370				30,00	30,00
360				30,00	30,00
350			30,00	30,00	30,00
340			30,00	30,00	30,00
330			30,00	30,00	30,00
320			30,00	30,00	30,00
310			30,00	30,00	30,00
300		30,00	30,00	30,00	30,00
290		30,00	30,00	30,00	30,00
280		30,00	30,00	30,00	30,00
270		30,00	30,00	30,00	30,00
260		30,00	30,00	30,00	30,00
250	30,00	30,00	30,00	30,00	
240	30,00	31,25	30,00	30,00	
230	30,00	34,03	30,00	30,00	
220	30,00	35,00	30,00		
210	30,00	35,00	30,00		
200	30,00	35,00	30,00		
190	30,00	35,00			
180	30,00	35,00			
170	30,00				
160	30,00				
150	30,00				

Tubo interno ø 63,5 / 76 Inner pipe ø 63,5 / 76
Tubo esterno ø 76 / 88,9 Outer pipe ø 76 / 88,9
Gancio ø 16 Pin ø 16



1 kN=102 Kg

High-quality optional nut

The shape of the lowering nut shows the direction for lowering when under load.

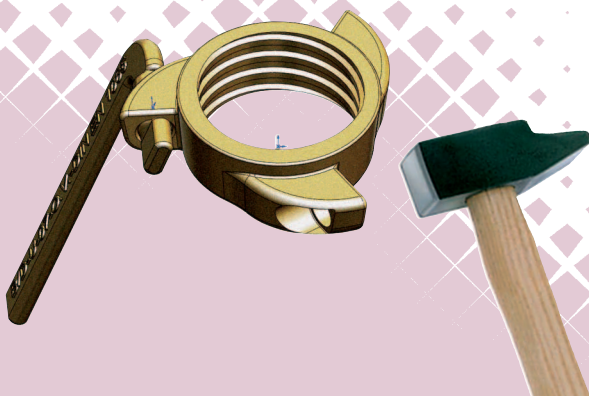



Officine Villalta
Ponteggi Fav3 | Puntelli | Tubo & Giunto

Stabilimenti e Uffici: 35010 GAZZO (PD) Italia - Via Vittorio Alfieri, 43 - Tel. +39 049 9425577 r.a. - Telefax +39 049 9425707
e-mail: amadio@officinevillalta.it - http://www.officinevillalta.it

OFFICINE VILLALTA SpA si riserva il diritto di modificare le caratteristiche tecniche, estetiche degli articoli in questo catalogo anche senza preavviso. È vietata la riproduzione anche parziale del presente catalogo senza l'autorizzazione scritta della scrivente società.
OFFICINE VILLALTA SpA has the right to modify the technical features, and the appearance of all the goods in this catalogue even without previous notice. Is forbidden the reproduction, even partial, without written authorization from the Officine Villalta SpA company (all rights reserved).