

⚠ WARNINGS AND CAUTIONS

Read through the User Manual prior to the first use of the cleaner and keep the User Manual for future reference.

Warnings

- Use the original charging adaptor only. Do not use an extension cable in any case. Keep a safe distance from combustibles when charging.
- Do not charge or use the cleaner when any anomaly is noticed. Please contact customer support.
- Do not operate the cleaner when people or animals are in the pool.
- This cleaner is not intended for use by persons (including children) with reduced physical, sensory or mental capabilities, or lack of experience and knowledge, unless they have been given supervision or instruction concerning use of the cleaner by a person responsible for their safety.
- Children should be supervised to ensure that they do not play with the cleaner.
- If the supply cord is damaged, it must be replaced by the manufacturer, its service agent or similarly qualified persons in order to avoid a hazard.
- Dispose of all packaging materials properly. Keep away from children and pets.
- This cleaner contains batteries that are non-replaceable. When the battery life ends, the cleaner shall be properly disposed of.
- The battery must be removed from the cleaner before recycling or disposal. The cleaner must be disconnected from the supply mains when removing the battery.
- Please dispose or recycle used batteries according to local administrative regulations. Consult a professional recycling agency when necessary.



Cautions

Use the cleaner in the following water conditions only:

- Chlorine: Max 4 ppm
- PH: 7.0 - 8.8
- NaCl: Max 5000 ppm
- Temperature: 6 - 35°C (43 - 95°F)
- Minimum depth: 0.5m/1.64ft. Maximum depth: 3m/9.84ft

- Do not operate the cleaner while the pool filter is running.
- Sunshelves or steps less than 50cm below water surface may cause the cleaner to get stuck.
- Climbs slopes < 25°. If there is a steep slope of more than 25 degrees from the deep end of the pool to the shallow end, the cleaner may not be able to leave the deep end.

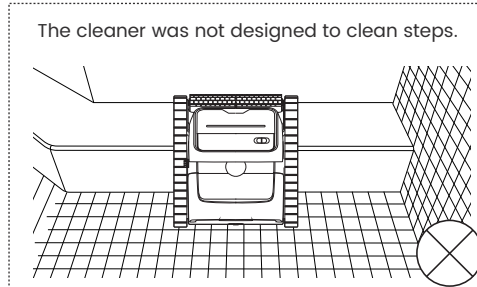

📦 PACKING LIST

| | | |
|---|---|--|
| <p>Cleaning Robot x 1</p> <p>With standard filter basket installed</p> | <p>Charging Adaptor x 1</p> <p>Plug type varies by country</p> | <p>Hook x 1</p> <p>User Manual x 1</p> |
|---|---|--|

📄 PRODUCT OVERVIEW

🎯 USING THE CLEANER

Charge your cleaner

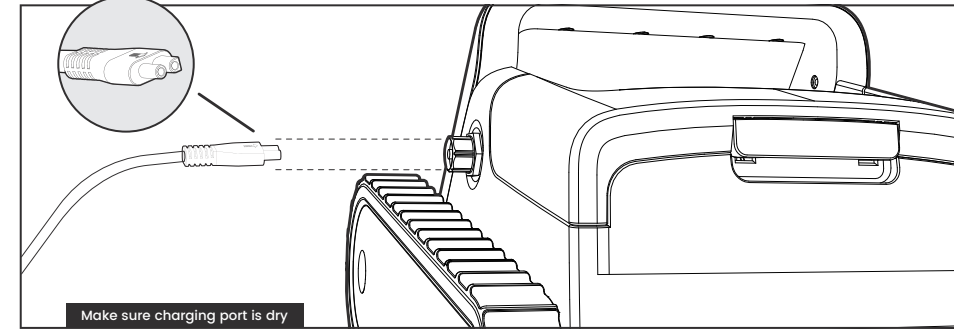

Turn on

| | |
|---|--------------------------------------|
| <p>1 Keep it still on level ground</p> | <p>2 Select cleaning mode</p> |
|---|--------------------------------------|

Don't move the cleaner before the indicator flashes yellow.

3

- ⏻ - Off/on
- Ⓢ - Standard Cleaning Mode: If you haven't cleaned your pool for a long time, or your pool is very dirty and you want to clean all pool surfaces, feel free to use Standard Cleaning Mode.
- Ⓡ - Floor Only Mode: If you clean your pool on a regular basis and only want to clean floor, feel free to use Floor Only Mode for daily cleaning.

Into the pool

Submerge the cleaner in the pool as soon as the indicator starts flashing yellow.

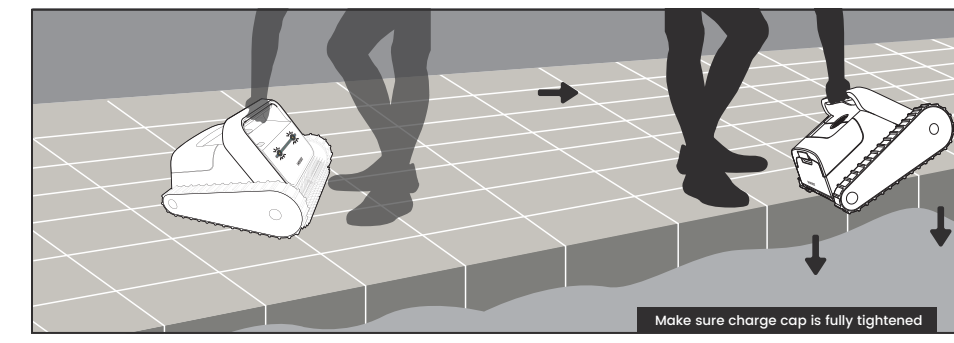

Hold it in water for a few seconds as it releases air trapped in it. Keep it steady and do not tilt.

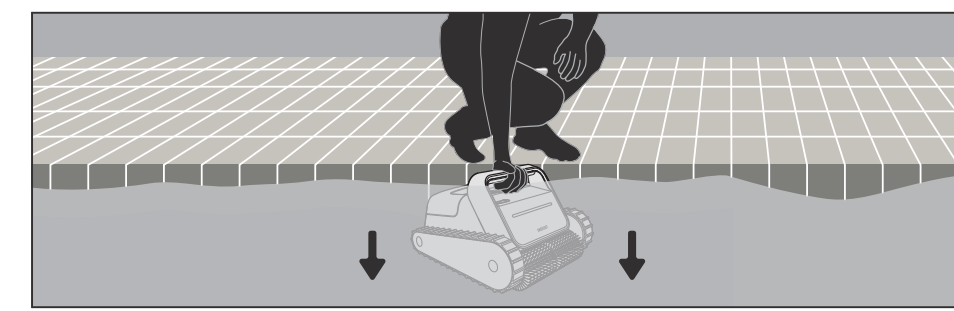

Release. It takes about 1-2 minutes to complete the self-test and start the cycle.

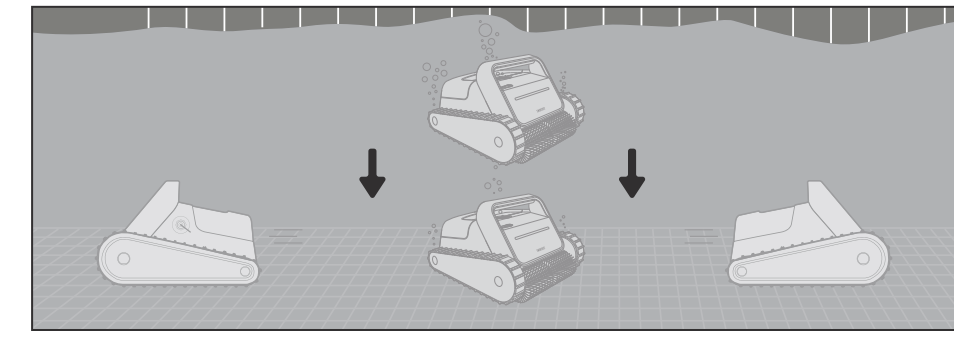

Out of pool

Automatically stop at the edge

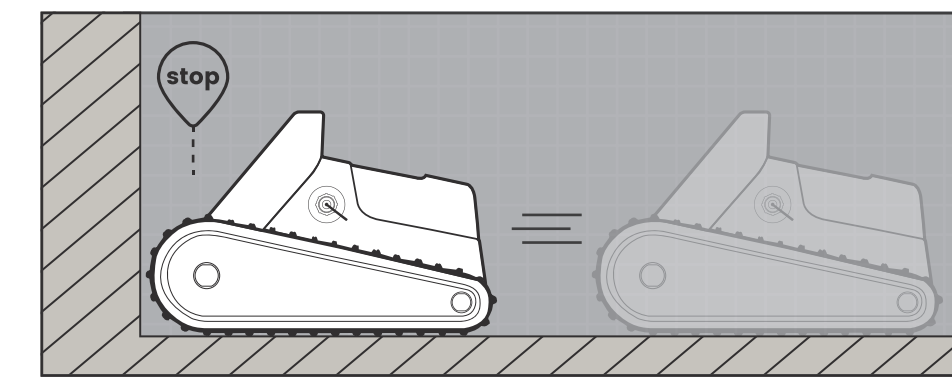

Pick it up with the hook

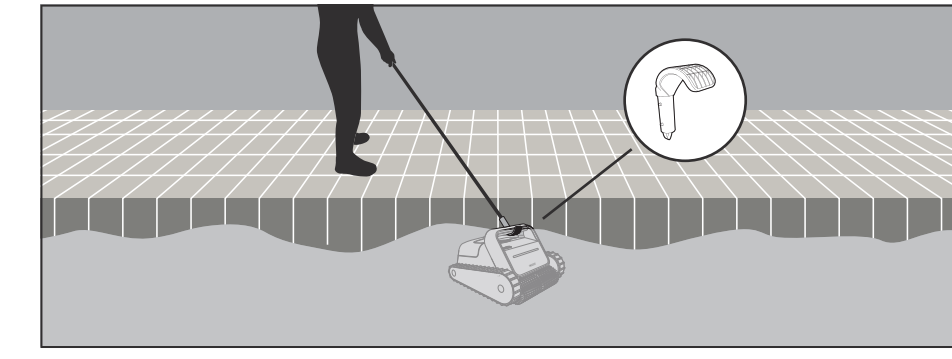

Turn it off

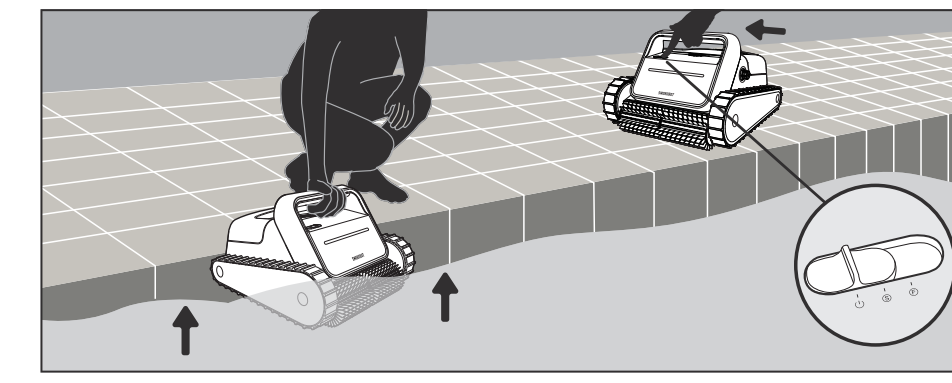

Clean the filter

| | |
|------------------------------|---|
| <p>1</p> <p>press</p> | <p>2</p> <p>pull</p> <p>take out</p> |
|------------------------------|---|

3

open latch

It is highly recommended to clean the filter basket after each cleaning cycle.

Note: Do not let the filter basket dry out before cleaning. Clogged filters will affect the overall cleaning performance of your cleaner by making it difficult to create suction or keep dirt and debris in the filter basket. Replace the filter basket when the cleaning results are not satisfying and cleaning the filter does not make a difference.

4

INDICATOR LIGHTS

1. Schematic diagram of the indicator lights.

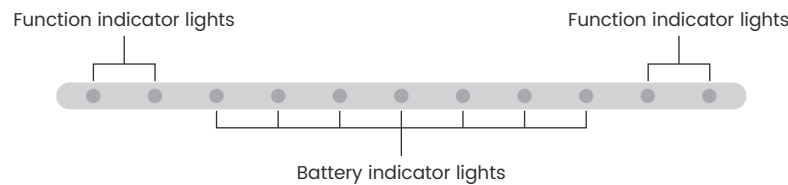

2. What is the meaning of the battery indicator lights in a cleaning cycle?

During the working process, the number of green lights gradually decreases. When there is only one red light left, it is in low power mode. The cleaner needs charging.

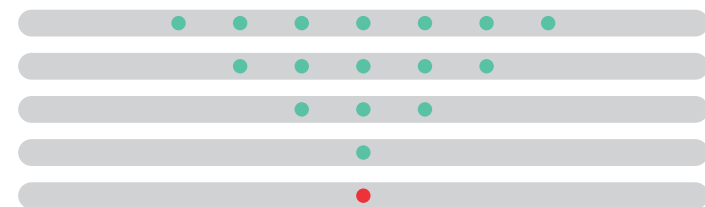

3. What do the battery indicator lights mean when charging?

When charging, the number of green lights will increase from 1 to 11, and the outermost two lights will flash until fully charged. When all 11 lights turn green, charging is complete. All lights will turn off after 10 mins.

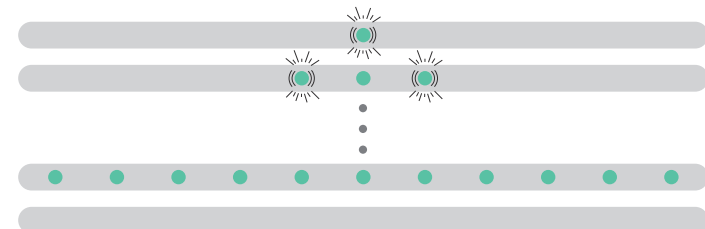

4. When should the cleaner be submerged in the pool?

When the two outer function indicator lights are blue, and the two inner ones are flashing yellow, the cleaner must be submerged in the pool as soon as possible.



5. What's the meaning of the white function indicator lights in a cleaning cycle?

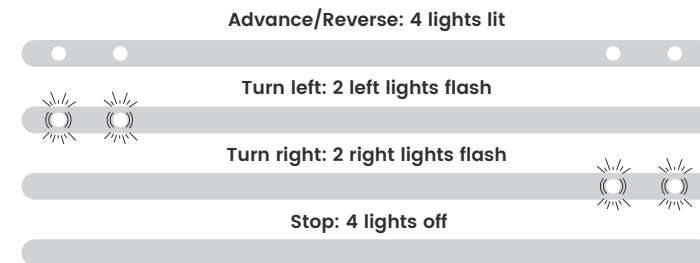

6. Cleaner fails to initialize.

When the two inner function indicator lights turn red, you need to turn off the cleaner, place it on a level ground and then restart it.



7. Motor is stuck when cleaner is working underwater.

- Left motor is stuck: Cleaner stops and left function lights flash red.



- Right motor is stuck: Cleaner stops and right function lights flash red.



- Both left and right motors are stuck: Cleaner stops and all function lights flash red at the same time.



- Pump motor is stuck: Cleaner stops and function lights flash red in turn.

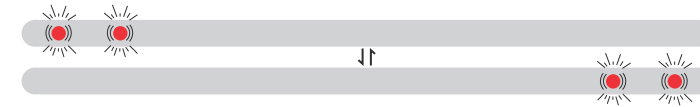

Note: It is normal to have water condensation behind the LED cover.

SPECIFICATIONS

Motor IP rating: IP 68
Minimum depth: 0.5m/1.64ft
Maximum depth: 3m/9.84ft

Charging Adapter
Input: 100-240VAC 50/60Hz 2.0A MAX
Output: 25.2V \pm 3.0A 75.6W

TROUBLESHOOTING

If the suggested solutions do not solve the problem, please contact your purchase channel.

| ISSUE | POSSIBLE CAUSE | SUGGESTED SOLUTION |
|--|--|---|
| Cleaner does not charge. | <ul style="list-style-type: none"> • No voltage in the power socket. • The power cable is not well connected into the power supply inlet. • Loose connection between charging adapter and cleaner. • Issue with the charging adapter. • Water got into charging port. | <ul style="list-style-type: none"> • Check there is voltage in the power socket in the wall. • Check the power cable is securely connected all the way into the power supply. • Check cable connection on both cleaner end and adapter end. • Check if the charging adapter shows green LED when disconnected from cleaner. If not, the charger needs to be replaced. • Dry the charging port and retry. |
| Cleaner does not turn on or indicator does not light up. | <ul style="list-style-type: none"> • Battery has run out. • Switch failure. | <ul style="list-style-type: none"> • Recharge the cleaner. • Try rebooting the cleaner. |
| Yellow light does not appear. | <ul style="list-style-type: none"> • Started on uneven ground. • Moved the cleaner during startup. | <ul style="list-style-type: none"> • Restart the cleaner on even ground. • Restart the cleaner and do not move it until flashing yellow light appears. |
| Cleaner moves but does not clean the pool. | <ul style="list-style-type: none"> • Filter basket full or clogged. • Debris stuck in the impeller. | <ul style="list-style-type: none"> • Clean/Replace the filter basket. • Remove debris stuck in the impeller. |

| ISSUE | POSSIBLE CAUSE | SUGGESTED SOLUTION |
|---|---|---|
| Cleaner does not climb the wall. | <ul style="list-style-type: none"> • Battery low. • Check if in F mode which means Floor Only. • Clogged filter basket. • Algae on walls, unsuitable pH level. • Worn tracks and/or brush rollers. | <ul style="list-style-type: none"> • Charge the cleaner. • Switch to S mode. • Clean/Replace the filter basket. • Check the level of the chemicals of the water. Improper levels may allow the growth of algae making the walls slippery. If so, adjust the levels and scrub the walls. • Replace tracks and/or brush rollers. |
| Cleaner is moving in circles. | <ul style="list-style-type: none"> • Clogged filter basket. • Debris stuck in track or roller. | <ul style="list-style-type: none"> • Clean/Replace the filter basket. • Remove debris from track or roller. • Check the cleaner according to CARE INSTRUCTIONS on page 11. |
| Cleaner stops underwater and function indicator lights flash red. | <p>Motor is stuck. Follow the instructions in "7. Motor is stuck when cleaner is working underwater" in section INDICATOR LIGHTS to identify which motor is stuck.</p> | <ul style="list-style-type: none"> • If left/right motor is stuck, turn the left/right track manually to see if it moves. If not, check obstacle in the track. • If pump motor is stuck, check obstacle in the impeller. • Check the cleaner according to CARE INSTRUCTIONS on page 11. |

OFF-SEASON STORAGE

If the cleaner will not be in use for an extended period of time, perform the following storage steps:

- Thoroughly clean and dry the filter basket, brush rollers, track treads and cogs.
- Make sure that no water is left in the cleaner.
- The cleaner must be fully charged before storing. It should be placed in a well ventilated and shaded location, at a temperature between 5°-45°C/41°-113°F, and humidity lower than 80%RH.
- Charge the battery at least once every 3 months to protect it from over discharging.
- Keep the cleaner out of the reach of children or persons with reduced physical, sensory, or mental capabilities, or lack of experience and knowledge, unless they have been given supervision or instruction.

CARE INSTRUCTIONS

For the best product performance, please clean and maintain your cleaner according to the following instructions.

1. After daily use

- Clean the product and the filter basket after each cleaning cycle.
- Keep it away from strong and direct sunlight.
- Make sure to dry up the charging port before charging.

2. Every 3-4 months or after a deep cleaning cycle when the pool is considered dirty.

- Check and make sure no debris is stuck in the impeller, track treads and cogs.
- CLEAN according to the instructions below. [0 0]

3. Every 12 months or before off-season storage

- Check track treads and brush rollers for wear.
- CLEAN according to the instructions below. [0 0]

1 Take off the side panel:

- Remove the two screw covers. Using a Phillips-head screwdriver, remove the two screws that hold the side panel and track tread in place. Take off the side panel and the track tread and place them to the side.

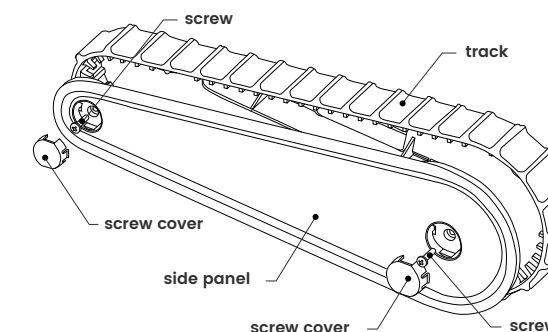

2 CLEAN:

- Clean the surfaces of the side panel. Take off the front wheel, the rear wheel and the transfer gear. Clean the parts with water or cloth and dry them.

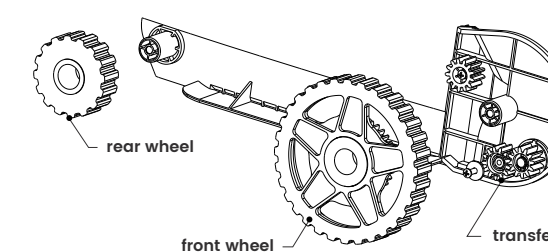

Contact support@smorobot.com for more information about care instructions.

SMOROBOT

USER MANUAL

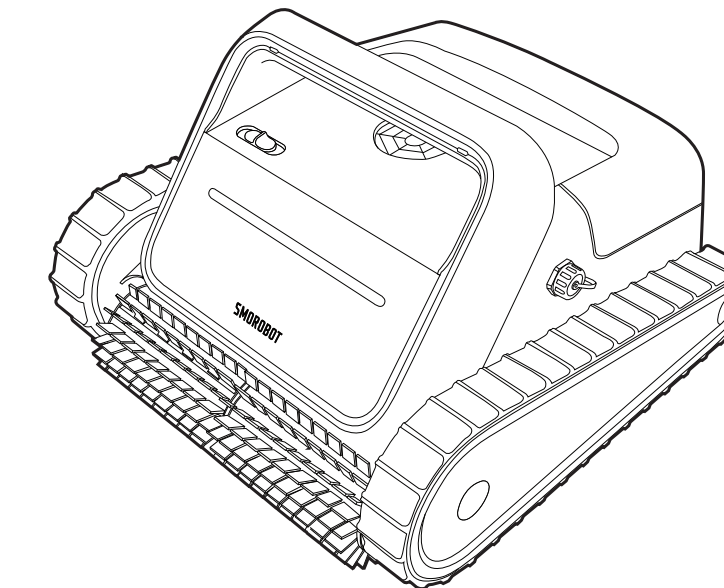

TANK X1C

INTELLIGENT ROBOTIC POOL CLEANER

Toll Free: +1 888-482-4564 (US)
E-mail: support@smorobot.com