

P.ONE

—
Automatic
throughfeed
moulder with
4 and 5 spindles



FUTURA 

**A winning
team
+ the talent
of a universal
champion**

FUTURA
Machines & Control
for Woodworking

FUTURA machines are the result of years of experience and research that have allowed the creation of tools optimized for each process, with great reliability and construction quality at minimum operating costs.

**High quality planing and moulding
at a reduced budget**

The FUTURA P.ONE series in particular allows high quality standards in planing and moulding with simple and reliable machines from the basic model.

With a choice of 4 standard spindles or 4+1 in the version with universal spindle, the P.ONE line is extremely versatile and enables all types of profiling operations to be carried out in full compliance with EC safety requirements.

Metalstar2000

P.ONE

Designed for excellent wood planing and moulding performance

Essential elements are the quality guaranteed by components 100% Made in Italy and its sturdiness. Available in 2 different versions with 4 spindles or complete with universal spindle to meet various moulding needs.

P.ONE 4

4 head planer/moulder



Considerable opportunities for use, both as four sided planer and as a moulder, to be able to bore and machine on 3 sides of the wood.

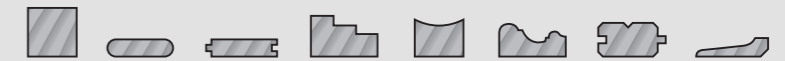

P.ONE 4+1

5 head planer/moulder



The model P.ONE 4+1 is equipped with a universal spindle that, as such, allows the wood to be processed on one of the 4 sides depending on the final product that the operator wants to obtain, thus making the machine extremely versatile in carrying out a wide range of processes.

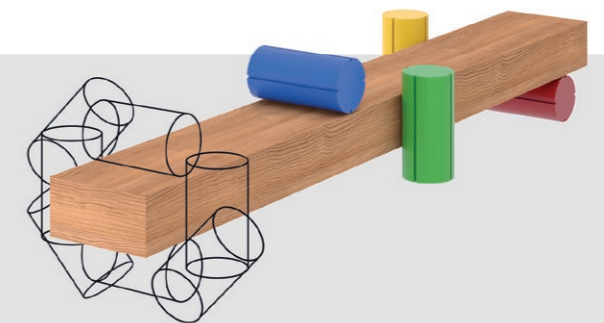

P.ONE

General Characteristics



- 1 Idle roller
- 2 Cardan joints
- 3 Universal spindle
- 4 Pass limiter
- 5 Powered rise and fall

Machine with 5 spindles

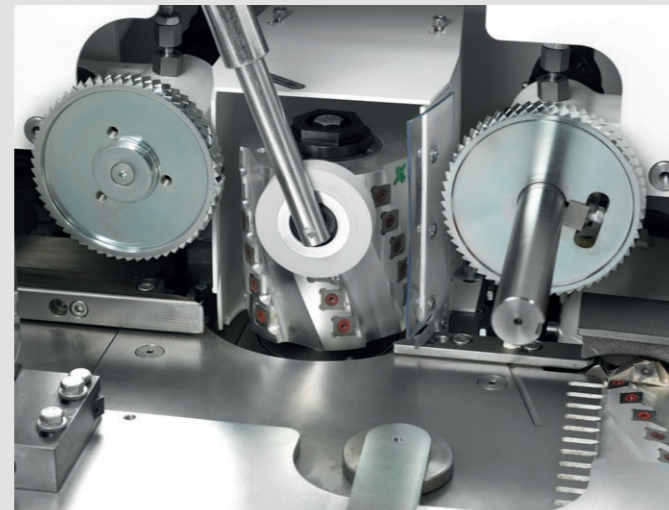
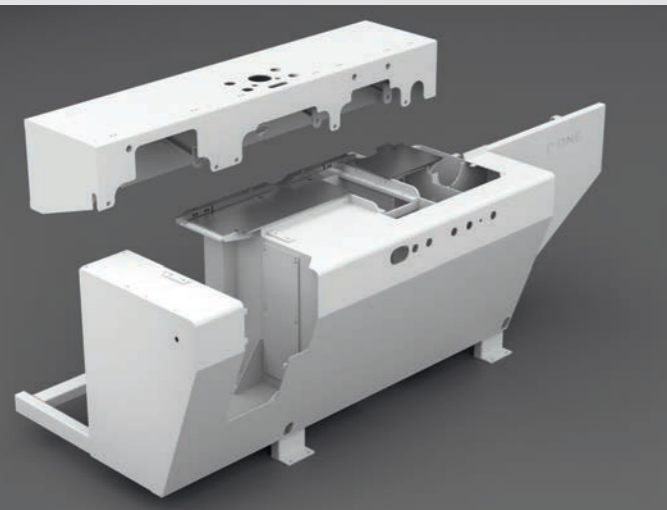
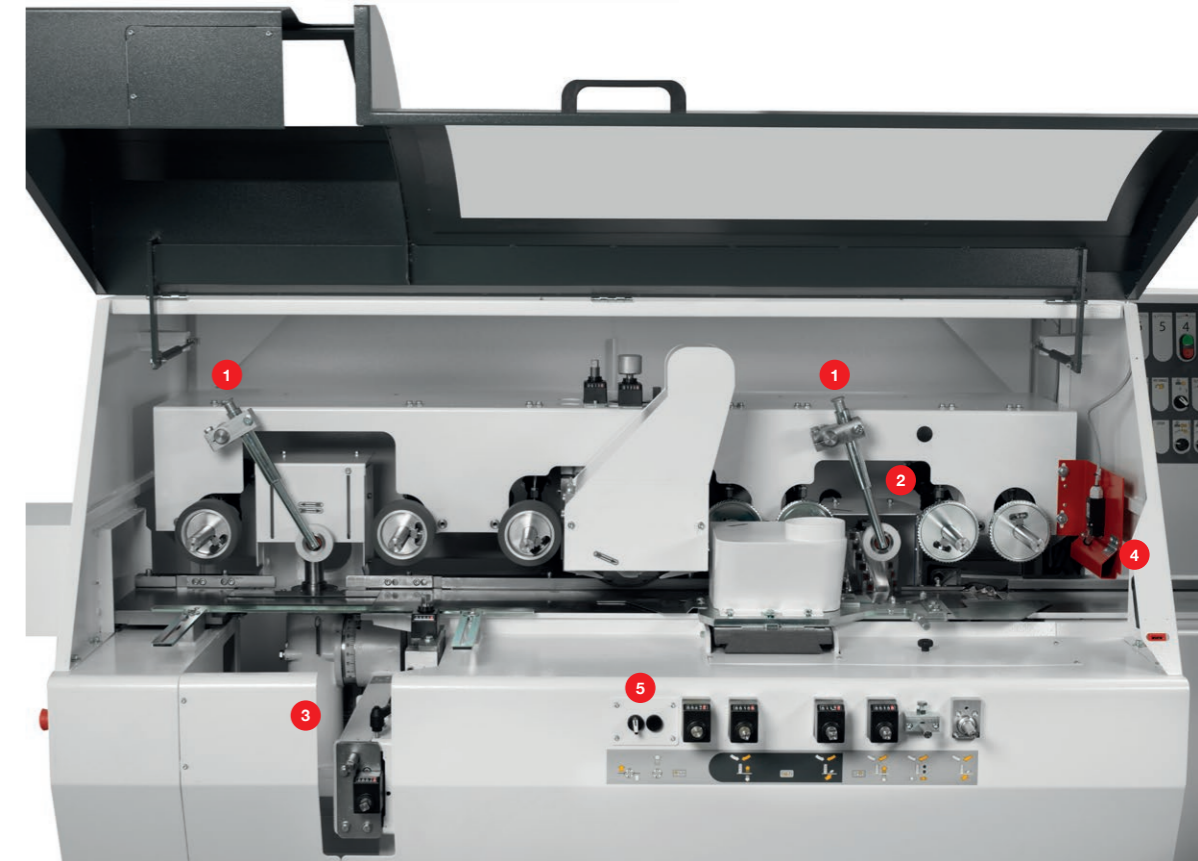

▲ MONOBLOC MACHINE BED

Machine bed and top beam designed to ensure high rigidity and stability of the machinery. Both are built with a monobloc iron structure, stabilized, sandblasted and painted with epoxy-polyester powder resistant to impact, light reflections and weather for durability.

▲ AIR BLOWERS AND ATOMISATION OF THE WORK TABLE

Even for the more problematic categories of wood pieces correct handling will be ensured. The system can be integrated with oil-air mixed atomisation to further improve wood pieces conveying.

▶ COMPACT DRIVE SYSTEM

Thanks to the reduced thickness, these belts are very flexible and can be suitable even for heavy-duty performances. Our pulleys are designed and manufactured with the utmost precision for a perfect fit with the belt grooves. An optimal & highly silent synergy that does not transmit vibrations.

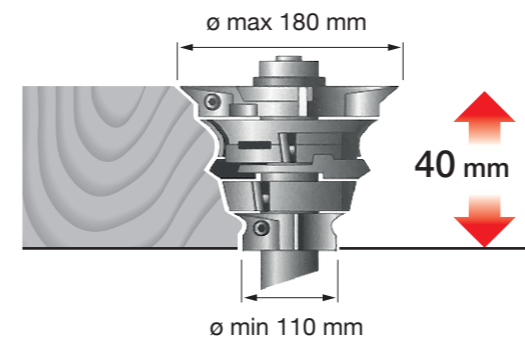
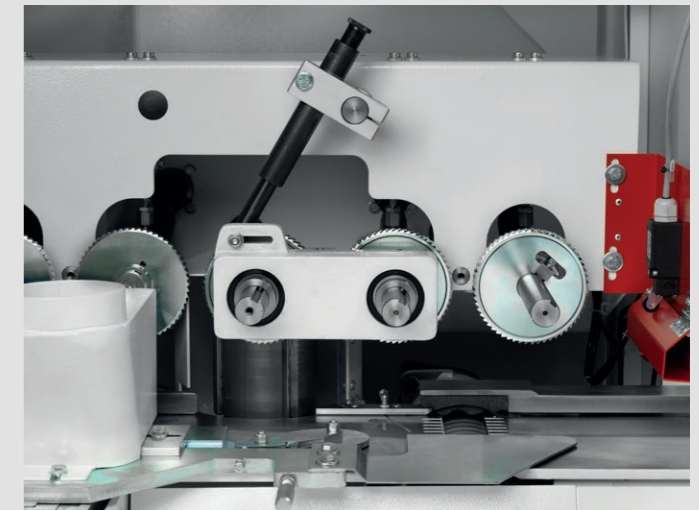

◀ PERFORMANCE

Tool diameter from 110mm minimum to 180mm maximum. Axial stroke of 40mm on vertical spindles for the management of multiple profiles.

▲ TANDEM

Located in front of the right spindle including toothed rollers to reduce the distance between the standard wheels. In this way, the machine can also draw and process short workpieces.

P.ONE

General Characteristics



100% Quality at 0 Km

The machines are entirely produced and assembled in Italy, every single piece is assembled in our headquarters in Rimini. Our company has laser cutting, welding and NC machining departments for a 0 km product. All the machines are scrupulously tested before shipment, on request tests are carried out with the customer's cutter blocks for a machine already ready to use.

2-AXIS PLC

Touchscreen PLC to store recipes. Icons for saving, opening and deleting recipes are easy and intuitive, very similar to that of PCs. Automatic axis positioning and start of spindle motors at the touch of a button.



UNIVERSAL HEAD

It can be used on all sides and offers the possibility of having an additional shaft on each side. Suitable for inclined milling. 360° flexibility.

Low power-consumption Solutions

The drive is made up of a motor-gearbox to make the most of the motor's kW. A power transmission that is synonymous with innovative, power-saving solutions.

3rd SPINDLE MOTORISATION AND ELECTRONIC DISPLAYS FOR WIDTH AND HEIGHT

As an alternative to the PLC we propose an economical system to speed up the machine setting by means of 2 buttons, 1 for rapid movement of the spindle, the other for positioning to the nearest tenth of a millimetre.



P.ONE

Technical Features



P.ONE 4

Increasingly high performance machinery due to the wide range of accessories available as standard, including: pneumatic pressure, pneumatic pre-planing roller, manual lubrication and air blowers on the work table, feeding by means of cardan joints and independent motor unit to each spindle.

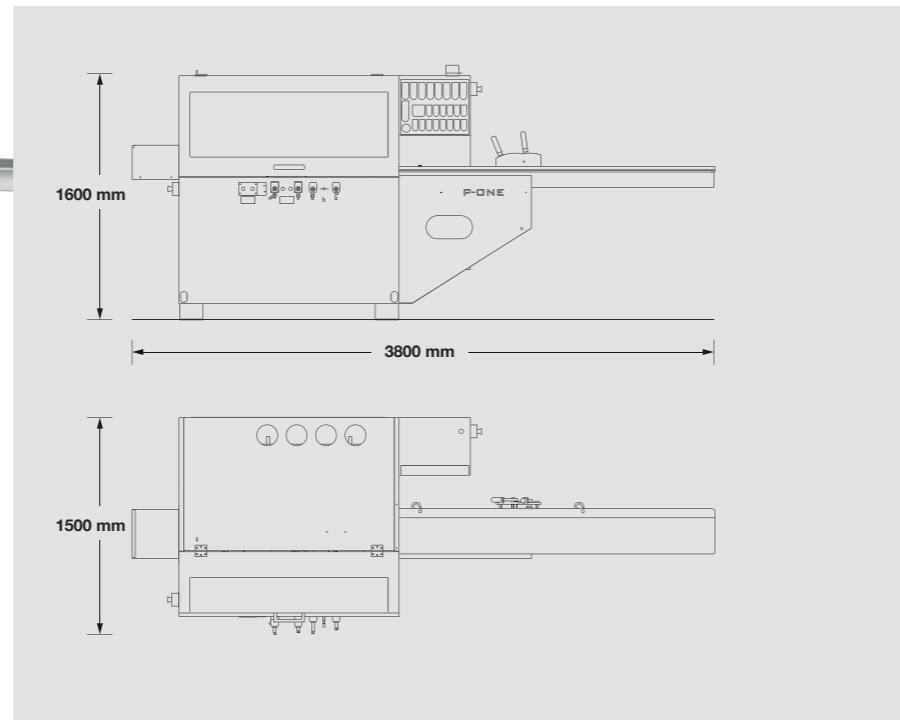

P.ONE 4+1

Machinery that embodies all the characteristics of its smallest sister with greater flexibility in processing thanks to the presence of the universal head movable at 360°. Complex profiles and excavations in the lower part of the wood can be made in a single step.

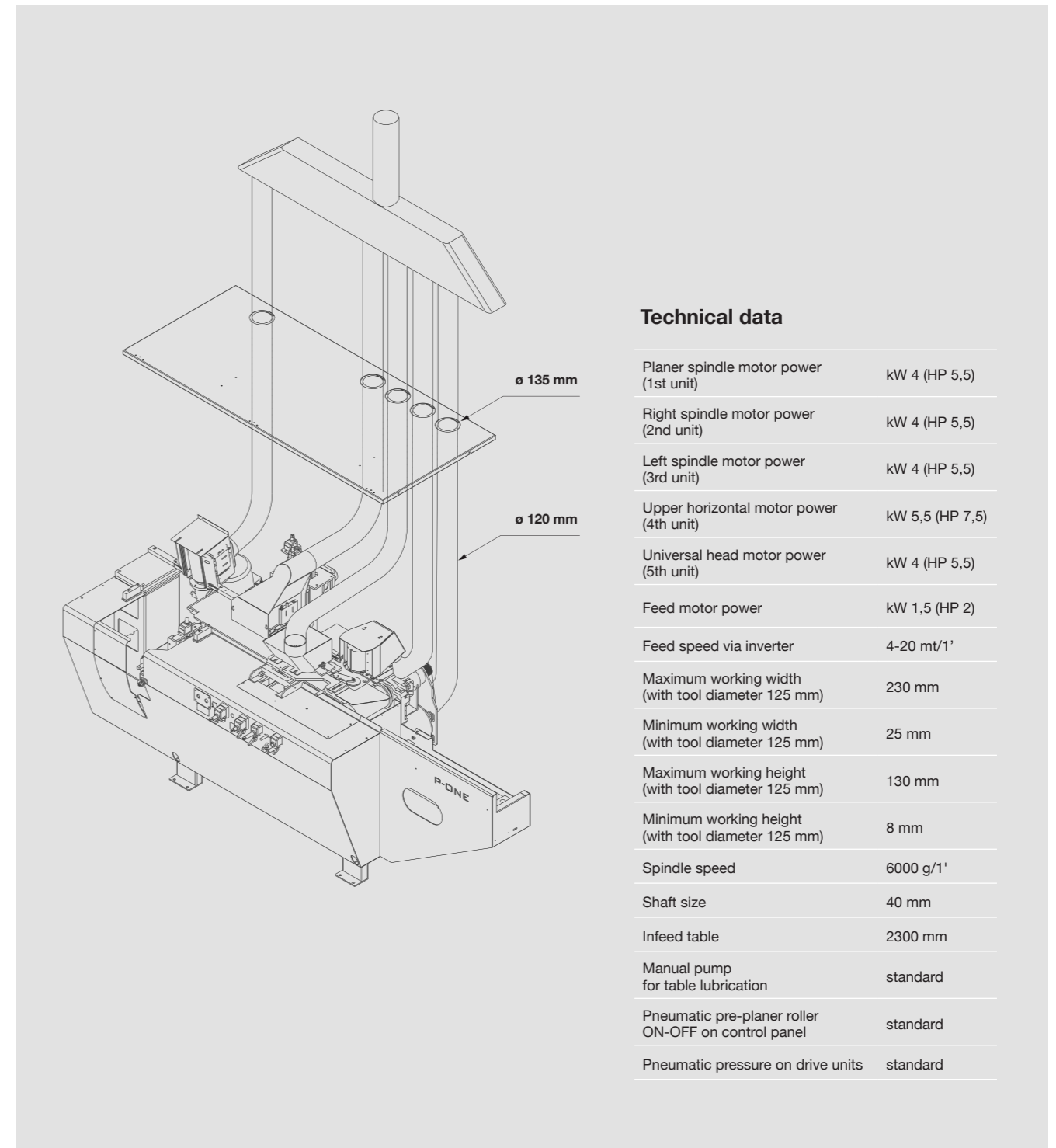
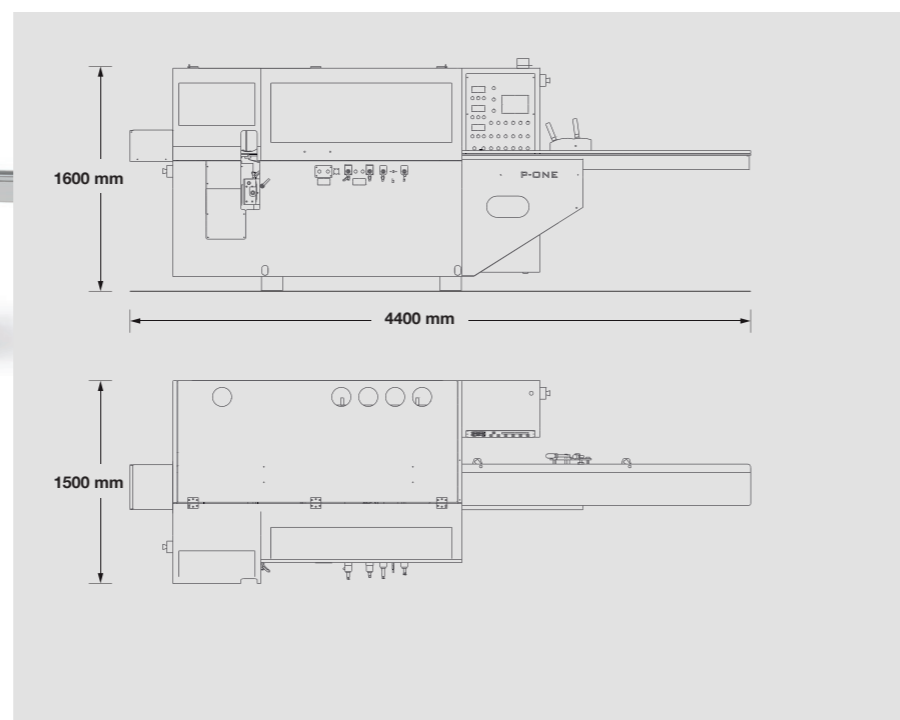

Technical data

Planer spindle motor power (1st unit)	kW 4 (HP 5,5)
Right spindle motor power (2nd unit)	kW 4 (HP 5,5)
Left spindle motor power (3rd unit)	kW 4 (HP 5,5)
Upper horizontal motor power (4th unit)	kW 5,5 (HP 7,5)
Universal head motor power (5th unit)	kW 4 (HP 5,5)
Feed motor power	kW 1,5 (HP 2)
Feed speed via inverter	4-20 mt/1'
Maximum working width (with tool diameter 125 mm)	230 mm
Minimum working width (with tool diameter 125 mm)	25 mm
Maximum working height (with tool diameter 125 mm)	130 mm
Minimum working height (with tool diameter 125 mm)	8 mm
Spindle speed	6000 g/1'
Shaft size	40 mm
Infeed table	2300 mm
Manual pump for table lubrication	standard
Pneumatic pre-planer roller ON-OFF on control panel	standard
Pneumatic pressure on drive units	standard

Metalstar2000



Metalstar 2000 S.r.l.

Via San Salvatore, 21
47924 Rimini (RN) - Italy
Tel. +39 0541 633022 - Fax +39 0541 731202
E-mail: commerciale@futura-woodmac.com
www.futura-woodmac.com

For demonstration purposes, some photos illustrate machines complete with accessories.
Metalstar 2000 reserves the right to change any specifications without giving prior notice.