

E-Brake 35-130T

Press brakes with an E for electronic



35-130T



The E-volution in sheet metal working

The E-evolution in sheet metal working increases your competitive strength as a manufacturer

The E-evolution in sheet-metal working

SafanDarley is the new global brand of sheet metal working machines, created by the merger of Safan and Darley. SafanDarley represents a unique combination of expertise and innovative power.

E-Brake

35-130T



SafanDarley offers innovative solutions for all types of sheet-metal working, applying revolutionary electronic or hydraulic technology. These innovations are the continuation of our previous milestones, such as the first CNCK servo-hydraulic brake press in 1980, the first servo-electronic brake press SMK in 1995, the first hybrid guillotine shearing machine in 1999 and the first fully-fledged electronic brake press, the original E-Brake, in 2004. This revolutionary machine concept started a global 'E-evolution in sheet-metal working'.

SafanDarley now offers a unique programme of electronic brake presses, from the E-Brake 20T Ergonomic to the E-Brake 300T Dual Drive. In the heavier segment too SafanDarley is the leader in innovation, as evidenced by the new generation SafanDarley H-Brake with its unique durable hydraulics.

All SafanDarley machines are operated by means of SafanDarley e-Control or TS Touch Screen control, the most user-friendly Man/Machine interface available. The combined expertise of SafanDarley is particularly strong in the field of

automated bending cells and client-specific production solutions, with custom-made machines if so desired.

SafanDarley continues to work on new, more efficient solutions under the motto of 'the E-evolution in sheet-metal working'. Electronics play an increasingly larger role in that respect. Among other things, this has resulted in the second generation E-Brake with pressure forces ranging between 35 and 130 tons.



SafanDarley E-Brake: The new generation



E-Brake 130T-4100



The E-standard
for Efficiency

The E-standard
for Ergonomics

The E-standard
for Economy

The E-standard
for Ecology

The second generation of SafanDarley E-Brake adds important new advantages to an already proven worldwide E-Brake technology. The machines in the 35T to 130T range are built according to a modular concept, ensuring an advance in the efficiency of machine technology. The new design is in line with the design of the heavier E-Brakes. Important features are the new backgauge and the larger stroke. There are a variety of other improved features and specification options available. In short, the new SafanDarley E-Brake means an important step forward in the E-evolution of sheet-metal working.



The E-evolution in sheet metal working

Servo-electronic bending with an E for even bending

Without crowning you obtain the most accurate and constant bending angle along the full working length of the machine. The unique, patented roller drive system in the upper beam ensures a uniform and even distribution of forces. A balanced combination of powerful electro-motors, fixed and movable rollers and specially developed belts facilitate capacities of up to 300T.

E-Brake
35-130T

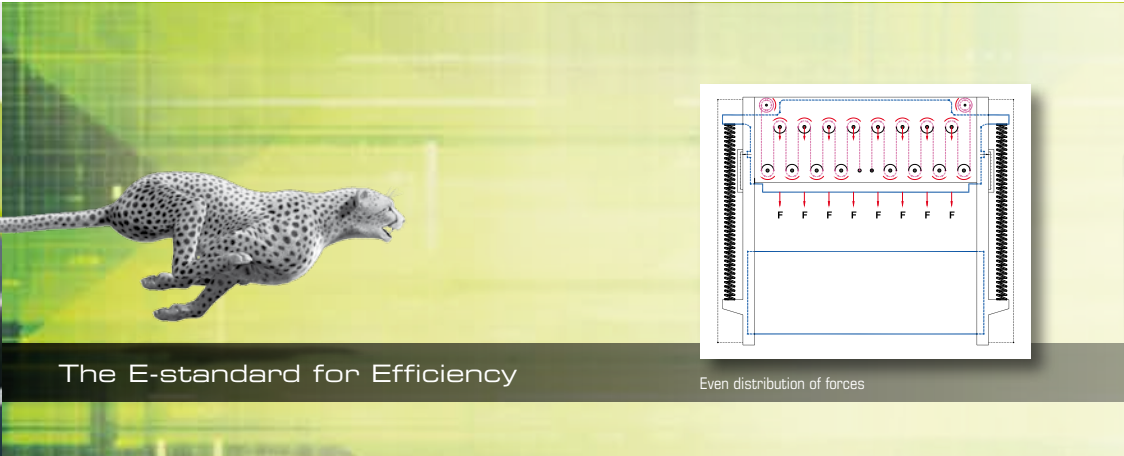

The E-standard for Efficiency

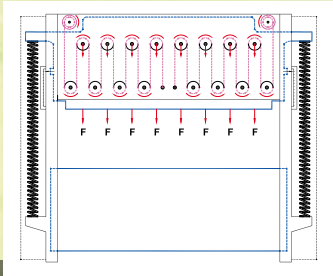

Even distribution of forces

Roller drive with 2 servomotors

The flexible belts, which are only 3 mm thick and 50 mm wide, are reinforced with steel wires and coated with hard polyurethane. This advanced technology has been extensively tested in the demanding elevator industry. So reliable is the technology that SafanDarley are able to offer a 5 year warranty on the mechanical drive system, when combined with an annual service contract. The special construction of the SafanDarley E-Brake also contributes to the even absorption of large forces. The O-frame acts as a single unit and deformation is kept to an absolute minimum. It is more stable, stronger and produces less deformation than a conventional C-frame.

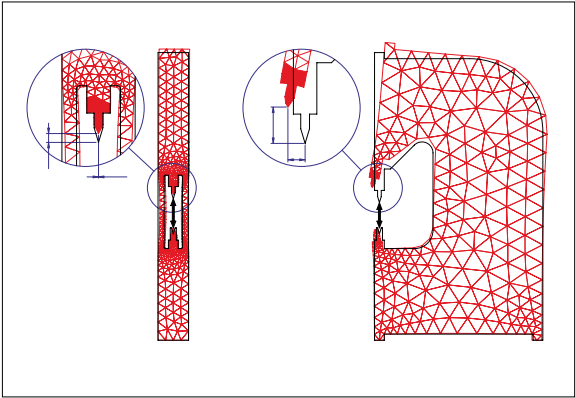

E-Brake

Conventional



The unique pulley drive of SafanDarley has proven itself around the world

Up to 30% shorter cycle times

The new SafanDarley E-Brake is further optimised to take maximum advantage of the high acceleration and other favourable servo-motor characteristics. For this reason, our E-Brake is not only very fast in the rapid approach stage, but also throughout the entire cycle.



E-Brake 130T-3100

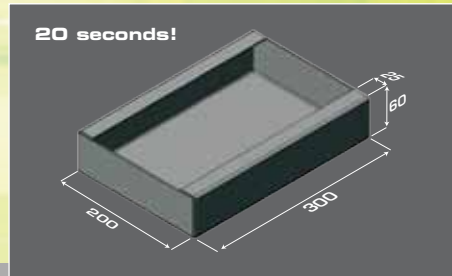

Test product: 20 sec. cycle with SafanDarley E-Brake!



Bending test product

SafanDarley's self-developed controls make use of a new generation of electronics and software. This results in incredibly short reaction and stop times, through which bending speeds of up to 20 mm/sec can be achieved. Cycle times are also far shorter than with conventional press brakes, partly through the fast backgauge. In comparison tests, the SafanDarley E-Brake is shown to be up to 30% faster than a conventional press brake. Cycle times for this product (see image below):

Up to 50% energy saving

The SafanDarley E-Brake only uses energy when the top beam is actually moving. This can deliver an energy saving of up to 50% compared with conventional hydraulic press brakes.

SafanDarley E-Brake 50T 2050	Cycle time 20 sec.
Conventional hydraulic press brake	Cycle time 35 sec.

Innovation with an E for efficiency

Following the success of the first generation of E-Brake and the breakthrough to the heavier 300T segment, SafanDarley has continued to optimise the machine concept. What could be improved even more in the construction, how could working with machines be made more efficient? The answer was found in a modular construction of the E-Brake, a new backgauge and a larger stroke.

E-Brake

35-130T



The E-standard for Economy



Backgauge with X-, R- and Z1+Z2-axes



Backgauge with X-, R-, Z1+Z2- and Delta X-axes

Modular machine concept

The greatest innovation of the SafanDarley E-Brake is the way in which the machines are built. Thanks to the new modular concept, every machine in the range can be produced more efficiently and delivered faster, from the 35T - 1250 to the 130T - 3100. The standard daylight opening (Q-dimension) is 590 mm, and you also have the option of choosing 650 mm or 690 mm.

Incredibly stable backgauge with CNC-driven X and R axes

Newly developed construction means that the innovative backgauge system of the SafanDarley E-Brake is extremely stable. The system is unique, as the backgauge is used across the entire length of the machine. Moreover, it is very precise through the electronic control system (0.02 mm). The backgauge has a

positioning speed of 350 mm/sec. CNC-controlled X- and R-axes come as standard, as well as hinging backgauge pins and a reach of 1000 mm.

Options

The backgauge system can be optionally complemented with CNC-controlled Z-axes and a Δ X-axis.

Tool clamping system

The E-Brake comes with the New Standard Premium MC mechanical tool clamping system. The New Standard Premium MC hydraulic tool clamping system is an option. European Style clamping is also an option (only in combination with a Q-size of 650 mm).



Moveable and adjustable support arms

SafanDarley has developed a range of support arms of modular construction for both light and heavy-duty sheet-metal work. This makes it possible to rapidly set up the correct solution for each application. An optimum combination of ergonomics and efficiency.

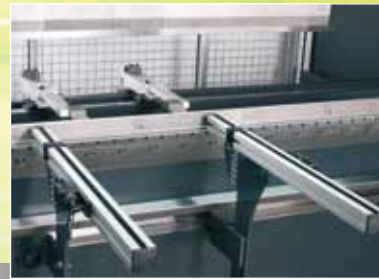

Movable support arms



Movable support arms adjustable in height

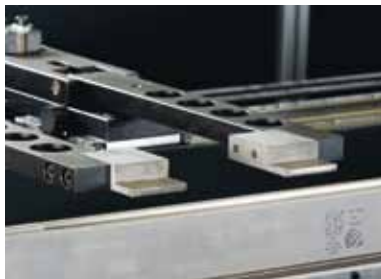

Standard backgauge stops

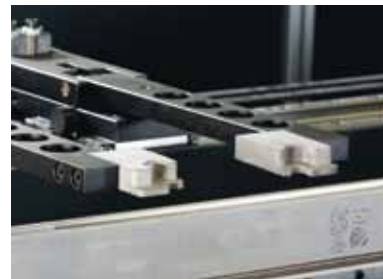

3D backgauge stops

All support arms can be used in combination with the light guard. The support arms are as standard equipped with brushes. You can choose from the following possibilities:

- Support arms fixed to the machine
- Support arms movable across the front side of the machine
- Support arms movable across the front side of the machine and height adjustable with a handwheel

- Support arms movable across the front side of the machine and pneumatically adjustable in height (programmable on the control)

Optionally all support arms can be equipped with adjustable front stops

SafanDarley E-Control, the new E-standard in ergonomics

Since the introduction in 1995, the SafanDarley TS-controls have been the international standard for ease of operation. The Safan touch screen concept is therefore the most functional and intuitive Man-Machine interface in the sheet-metal working industry. Safan have once again shifted the standards with the SafanDarley E-Control as the latest generation touch screen controls.

E-Brake

35-130T

The E-standard for Ergonomics

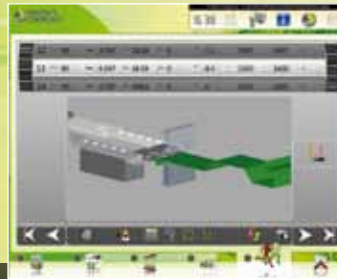

SafanDarley EC20 control



SafanDarley EC30 control

Complete Touch Screen convenience

The SafanDarley E-Control is fully touch screen, whereby the only buttons visible on the 17" screen are those that are needed during operation. The controls simply run on a PC under Microsoft Windows®, the software was developed based on Microsoft.net Framework. The unit is fitted with a 100 MB Ethernet UTP network connection as standard. The instructions are transmitted to a central processor from the SafanDarley E-Control controls, which in turn regulates the various axis via a so-called CAN-BUS (Control Area Network). The system

can be programmed quickly and accurately thanks to a 'self-teaching' database with data on materials, tools and previous, already corrected bending. The SafanDarley E-Control can be coupled to the majority of off-line programming systems. The standard E-Control 20 facilitates both numeric and 2D graphical programming. It is possible to draw a complete product by means of touch screen and to then automatically generate a bending program. The developed length is also calculated. The optional E-Control 30 can be used to generate 3D drawings.

Web-based communication and support

The controls are set-up for web-based communication such as online diagnoses and loading software updates via the web. Machines can also be coupled to each other in a group and tooling databases can be shared. By monitoring and analysing your operating data online, Safan will be in a position to optimise your production process from a distance in the near future.



SafanDarley TS control with keyboard

Summary of SafanDarley press brake controls EC20 - EC30



SafanDarley Easy EC20

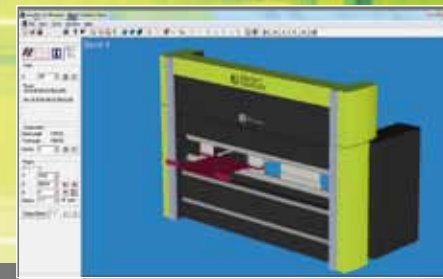

Off-line programming with AutoPOL for Windows



Control type	Possibilities	Off-line connections to
EC20	Numerical product data entry by means of touch screen - extensive tools library - numeric entry of bending parameters - usage of the actual database - 2D programming of products automatic bending sequence calculation with EC Profiler - 2D and 3D graphic display of products programmed offline for Autopol and Radan	- SafanDarley EC software - Delem Profile on Windows - Delem V-Bend - Autopol - Radan
EC30	As EC20, but with graphical 2D and 3D programming and representation of the bending sequence	- SafanDarley EC software - Delem Profile on Windows - Delem V-Bend - Autopol - Radan

Bending with an E for efficient options

Fast, simple and reliable angle measurement can be essential for your bending process. SafanDarley has made E-volution advancements in this area too. Two SafanDarley E-Bend systems, electronically linked to the SafanDarley Touch Screen controls, increase your efficiency through exact sheet thickness or angle measurement.

E Brake

35-130T

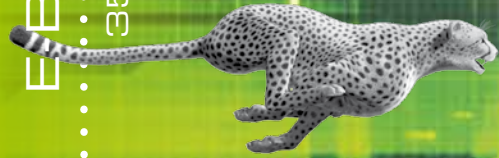

The E-standard for Efficiency



SafanDarley E-Bend S



SafanDarley E-Bend S

The SafanDarley E-Bend S sheet thickness measurement system is mounted next to the backgauge finger. The system measures the sheet thickness to an accuracy of ± 0.01 mm. It can be precisely programmed when measurement should take place. Measurement takes just tenths of a second and the data in the control system is immediately adjusted. The control system database maintains all records of measurement and is set out graphically.

SafanDarley E-Bend M

This system consists of two pneumatic sensors on a rail, which can be programmed at every desirable position. Both sensors are in contact with the sheet during the bending cycle. Before the definitive angle is bent, the spring-back of the sheet is measured. Based on this, a correction is entered after which the definitive angle is bent. The values measured can be used for other bends in which angle measurement is not possible due to the product's geometry.



SafanDarley E-Bend M

SafanDarley E-Mate bending aids

With the electrically-driven E-Mate bending aids from SafanDarley, you prevent angle deviation when bending thin sheets with large dimensions. The bending aid provides the operator with a simple and ergonomic means to remain within set angle tolerances.



SafanDarley E-Mate



SafanDarley E-Mate Plus



It is often not easy for an operator to position large sheets. Certainly during the return movement of the top beam, it is difficult work to keep everything in hand. Instead of having a second operator provide assistance, it is frequently more efficient to install a SafanDarley bending aid. In most cases, it can be used by a single man to position larger products. In brief, along with accuracy, productivity is increased by the SafanDarley E-Mate, the best partner for your operator.

In order to relieve the operator in the case of long, routine, heavy duty work, SafanDarley has developed an extremely powerful and highly accurate bending aid. The bending aid supports and follows the sheet with great accuracy throughout the entire bending process.

Machine type	Max. sheet weight
• E-Mate	30 kg.
• E-Mate plus	150 kg.



Electronic evolution with an E for ecological and economical

E-Brake

35-130T



The E-standard for Ecology

Side view

The SafanDarley E-Brake contributes perfectly to your sustainable business, while at the same time making your business operations much more economic. The absence of hydraulics means that the problems associated with environmentally harmful and risky oil are a thing of the past.

There is no need to adjust the settings of pressure relief valves – with the risk of mistakes and drift – and there are no filters to be checked and replaced. The servo-electronic system is therefore far more reliable than the hydraulic one, because of the lack of oil, tanks, pumps, seals, valves and filters. And you will never have trouble with a cold start up.

Integrated safety

Work fast without risk: SafanDarley makes that a reality with the safety system integrated within the controls. It works with a safety light screen that is automatically directed from the SafanDarley TS controls. In addition, the SafanDarley E-Brake has an additional in-built safety provision. The application of a spring return means that the top beam will always move upwards in the event of a failure.



Integrated safety light guard

Turn-key delivery of automated bending solutions

In 1988, SafanDarley had already installed the first robotic press brake in Europe. SafanDarley is now an experienced specialist in the field of automated bending cells including the standard SafanDarley R-Brake. The SafanDarley integral solutions for your production process go much further than stand-alone solutions.



The integral automation is not restricted to the bending cell alone, this also applies to other parts of the process such as punching and spot-welding, and the entire routing of sheet material around the bending cell.

Flexible solutions and off-line software

You retain your flexibility with SafanDarley in terms of new products or changes in your production process. You are also flexible in relation to coupling with external systems and choosing your robot. The SafanDarley

E-Brake is perfectly suited to operate as a mid-point for every automated bending cell. The SafanDarley controls run under the Windows® platform, adding a whole range of options for links, networks, software packages and resolving downtime of the unmanned production process over the Internet. SafanDarley can supply complete, fully tested programs for both new and existing robotic cells. You have a choice between off-line or parametric programming. Naturally, you can contract out all programming to SafanDarley.

The SafanDarley Robowave off-line programming is a guarantee for maximum efficiency of your bending cell. All movements can be programmed and simulated in advance.

From advice & consultancy to manufacturing

SafanDarley makes automation of sheet-metal working easier than you think. This starts with the convenience of a single contact person for the entire project. Our consultants clearly present you with the entire range of options, enabling you to make the best possible choice for your production

process. SafanDarley develops and realises turnkey solutions for bending and cutting systems with guaranteed cycle times. This fixes the costs per product. The return time of your investment can be properly determined based on those set costs. With the help of a simulation model, you will get a reliable indication beforehand of your expected Return On Investment.

SafanDarley E-Brake energy consumption

On the SafanDarley E-Brake, the main drive motor is used only when the E-Brake has to actually perform a movement. With a conventional hydraulic press brake, the hydraulic pump motor is running all the time.

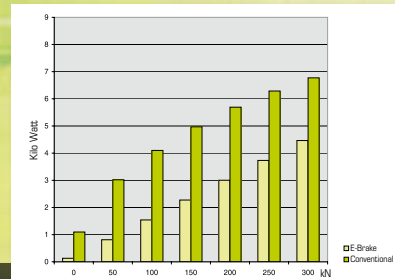

SafanDarley E-Brake energy consumption

The graph above only covers the time while the press brake is actually in operation. During the standby time - which can be as much as 90% on account of sheet handling, machine set up and intervals - this will mean a further saving with the E-Brake up to 3000 kWh a year.

Standard features

- SafanDarley EC20 Touch Screen CNC press brake control
- CNC-controlled R- axis
- CNC-controlled Y1-Y2 axis (top beam adjustable inclined +/- 2.5 mm)
- CNC-controlled back gauge (X-axis) with a wide range
- Manual variable adjustment of back gauge fingers width across a linear guide
- NSCL II MC Premium top tool mechanical clamping system and OB/S-3 lower tool mechanical clamping system
- Daylight of 590 mm (Q-dimension)
- 2 support arms (300 mm in length)*
- 1 Hold to Run operating console
- Programmable and integrated safety light guard*
- Safety in conformance with CE*

*Standard only for CE countries

Tool adapters SafanDarley E-Brake

The diagrams show various tool adapters with their dimensions and clamping methods:

- NSCL II MC Premium:** Dimensions 80.0, 84.
- NSCL II HC Premium:** Dimensions 80.0, 80.
- ASCL I MC Pro:** Dimensions 80.0, 59.
- ASCL I HC Pro:** Dimensions 80.0, 80.
- EURO STYLE MC:** Dimensions 80.0, 100.0, 290.
- EURO STYLE Pneumatic clamping:** Dimensions 80.0, 100.0.

Three main configurations are shown with their Q-dimensions and strokes:

- STANDARD:** Q = 590mm, Stroke = 300mm
- 3.0.8130:** Q = 650mm, Stroke = 300mm
- 3.0.8140:** Q = 690mm, Stroke = 300mm

Operator side views show additional dimensions for different models:

- OB/S-3:** Dimensions 80, 95.0.
- OB/S-3 European style:** Dimensions 80, 95.0.
- OB/S-3/C MC/HC:** Dimensions 90, 95.0.
- OB II MC Premium:** Dimensions 72, 30, 110.
- OB II HC Premium:** Dimensions 87, 42, 110.0.
- DD005 MC/HC + OB/S-3/C MC:** Dimensions 70, 17, 115.0, 95.0, 15 mm.

Technical specifications

SafanDarley E-Brake 35 - 130T

E-Brake 35-130T	Pressure force in kN	Maximum stroke in mm	Q size in mm	Closing speed in mm/sec	Bending speed max.* in mm/sec	Return speed in mm/sec	Motor Power in kW	Weight in kg	A in mm	B in mm	C in mm	D in mm
35-1250	350	300	590	180	10	180	11	3250	2230	1250	2510	3120
40-1600	400	300	590	180	10	180	11	3950	2580	1600	2510	3120
50-2050	500	300	590	160	10	160	11	4750	3030	2050	2510	3120
65-2550	650	300	590	140	10	140	11	5500	3530	2550	2510	3120
80-2550	800	300	590	90	10	90	11	5500	3530	2550	2510	3120
100-3100	1000	300	590	75	10	75	11	6350	4080	3100	2510	3120
130-4100	1300	300	590	110	10	110	15	9450	5080	4100	2710	3150

* Optional max. bending speed 20 mm/sec.

(Subject to modifications)

Accessories (optional)

- CNC-controlled Z1-Z2 axis (horizontal repositioning back gauge fingers)
- CNC-controlled Delta X-axis (horizontal repositioning of one back gauge finger)
- Built-in size increase up to 650 mm or 690 mm (Q-size)
- Various upper and lower tool adaptors
- Various bending aids
- SafanDarley E-Bend S sheet thickness measurement system
- SafanDarley E-Bend M angle measurement system
- Various support arms, fixed, moveable and adjustable in height where required
- Extra Hold To Run operating console (compulsory with 2 machine operators)
- Integrated tool cabinet
- Machine lighting
- SafanDarley E-Control press brake control:
 - EC30 control, complete 2D and 3D graphic programming

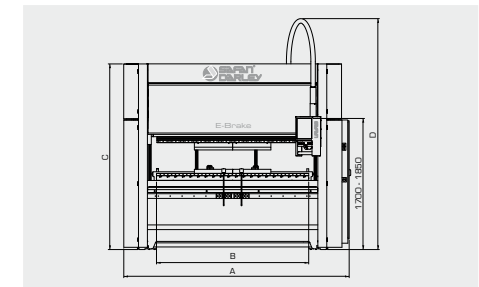
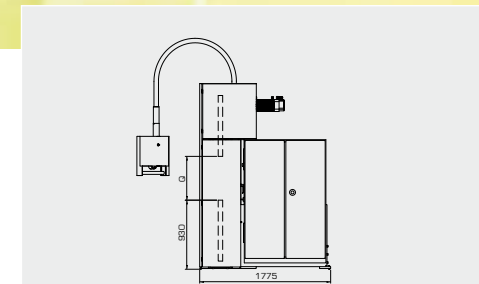
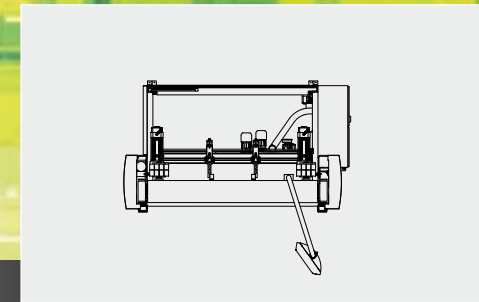



E-Brake Ergonomic

E-Brake 35 - 200T
E-Brake B 20 - 100T

E-Brake 300T Dual Drive

H-Brake

R-Brake

B-Shear & M-Shear

GS-Shear

Custom made solutions



Watch our corporate movie here:



SafanDarley B.V., Kwinkweerd 11, NL-7241 CW Lochem
P.O. Box 96, NL-7240 AB Lochem, The Netherlands
Tel.: +31 (0)573 222 222, Fax: +31 (0)573 252 057

E-mail: info@safandarley.com, Website: www.safandarley.com