

# AXEL 4

CNC Machining centre with 4 axes



CE

The AXEL 4 machining centre with 4 axes has been designed to carry out drilling and milling operations on aluminium or steel profiles. Because of the solutions used in its construction, AXEL4 is suitable to machine large section profiles. The 24,000 rpm, 22 kW electrospindle allows removal of a significant amount of chips and high machining speeds.

## Overall dimensions and weight

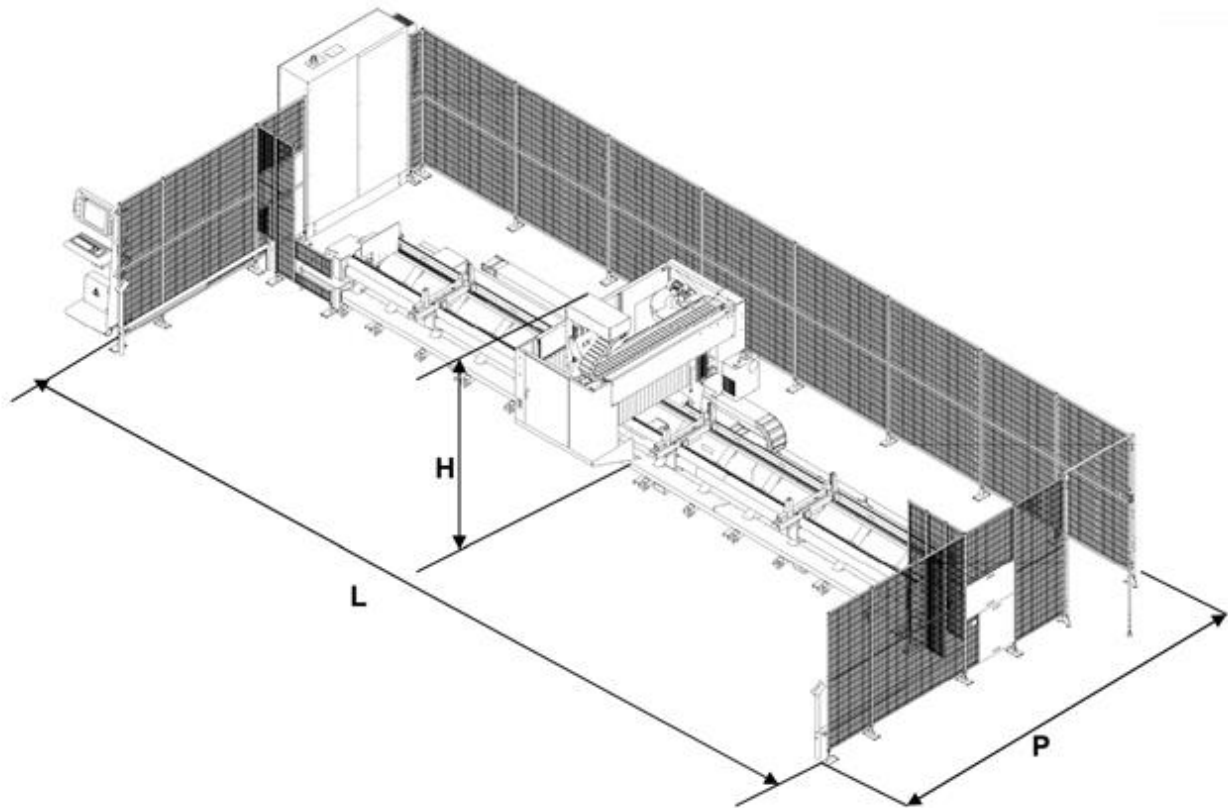

Version	L (mm)	P (mm)	H (mm)	Kg
AXEL 4 - 075	11920	5000	3020	4300
AXEL 4 - 100	14020	5000	3020	5600

- Weight of cabinet: 410 Kg
- Weight of single supplementary pneumatic vice: 75 Kg
- The weight of the fences and photocells is not included in the above stated values

Power supply	Total power installed	Air consumption for work cycle	Working pressure
3F - 380÷415 V - 50 Hz	26,5 kW	188 NL/min	7 bar



## Technical specifications:

### Structure

It consists of a machine bed and an electro welded and normalised steel upright sized to guarantee great stability and precision during machining operations. The conformation of the machine bed facilitates loading and unloading operations and minimises the build-up of waste. On request a motorized chip conveyor with ramp can be installed in the machine bed.

### Axes movement

The independent axis are controlled by brushless servomotors by means of:

- Pinion, rack and mechanical system for backlash recovery for X axis (longitudinal)
- High precision ground recirculating ball screw and preloaded lead for Y (transversal) and Z (vertical) axis. The Z axis drive is equipped with an electro-magnetic brake which is enabled if mains power is cut-off.
- Kinematic chain with ground gears for axis A and hydraulic locking system.

The servomotors used associate high speeds in rapid mode with short positioning and adjustment times. The position of the axes is detected by an encoder.

### Centralised automatic lubrication system

A system automatically sends lubricant to the sliding and movement elements at preset intervals without stopping the machine. The parts lubricated in particular are:

X axis: 4 slides of the linear guides and rack.

Y axis: 4 slides of the linear guides and recirculating ball screw nut

Z axis: 4 slides of the linear guides recirculating ball screw nut

A message displayed on the monitor informs the operator when the minimum level of lubricant has been reached in the tank.

A device is also supplied as standard to carry out manual greasing when necessary.

## Machining head

This allows machining on 4 sides of the profile and on the 2 ends with the aid of milling disks and blades.

## Electrospindle

The liquid cooled 22 kW and 24,000 rpm electrospindle provides power and reliability in every working condition. Supplied with SW module to carry out tapping

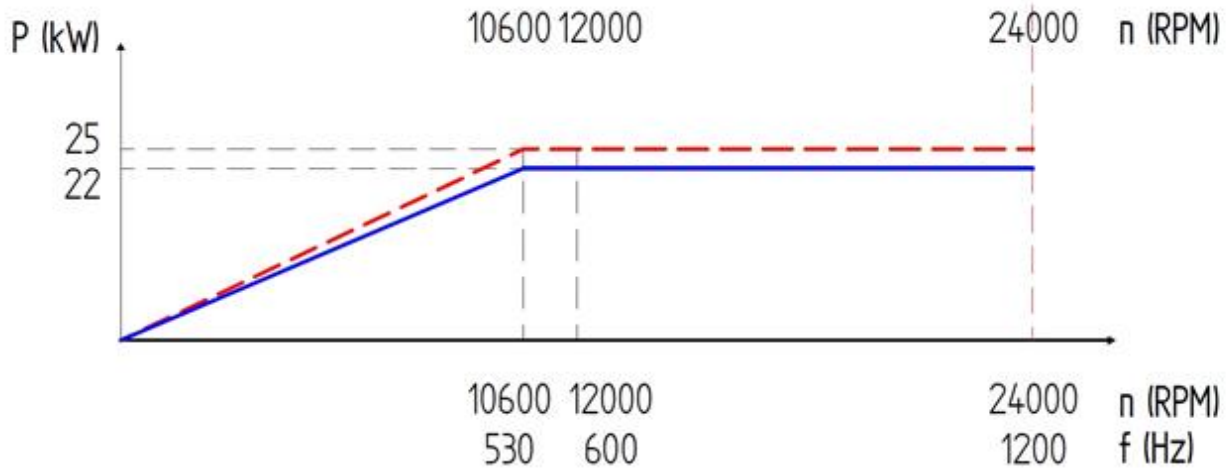

Three-phase Synchronous Motor 6 poles / Motore Sincrono trifase 6 poli  
Choke / Induttanza = 0.4 mH

## Technical specifications:

Tool-holder type	HSK E63
Weight	31 Kg
Direction of rotation	← →
Working position	↓ ↔
Bearings lubrication	Grease
Motor coolant	Fluid
Motor classification	Three-phase synchronous
Rated power	22 kW
Rated torque	20 Nm
Rated speed	10600 RPM
Max speed	24000 RPM
Insulation class	F
Index protection	54

Material	M max
Aluminium	M18* thickness 15 mm
Steel	M16* thickness 10 mm

\*with thread tap

## Tools lubrication

Minimum lubrication required. The lubricant used is pure oil or, additionally on request, a supplementary lubri-coolant system with liquid recovery tank.

## Tool magazine

It has 15 HSK E63 tool holders, is located on the carriage and turns in both directions to minimise the tool change time.

It may contain angular head units equipped with:

- a mill for machining operations on the lower surface or on the ends
- blade for cutting operations

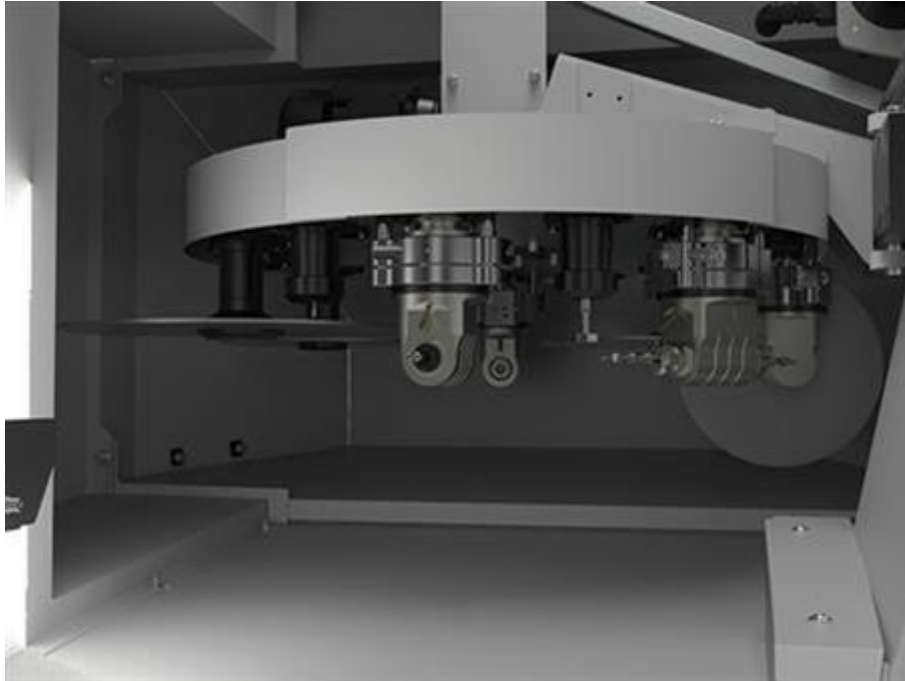

## Work area organisation

### Vices

They slide along the X axis on straight guides. Their small size reduces the need for repositioning and ensures firm locking very close to the machining point. Each vice has a centre roller to facilitate movement of the profiles during the loading phase, prevent chip deposit and therefore preserve the surface. The vice pressure can be set using a regulator with integrated pressure gauge (one regulation per working area). Automatic positioning is supplied as standard. Independent positioning by means of an additional axis can be supplied on request. The position of the jaw and the vice pad can be adjusted quickly without the use of tools. The jaw is adjustable to set positions, while the vice pad is adjustable to any position, to ensure ideal clamping in every working condition. On request, it is possible to increase the number of vices: numerous vice/stop configurations are available.

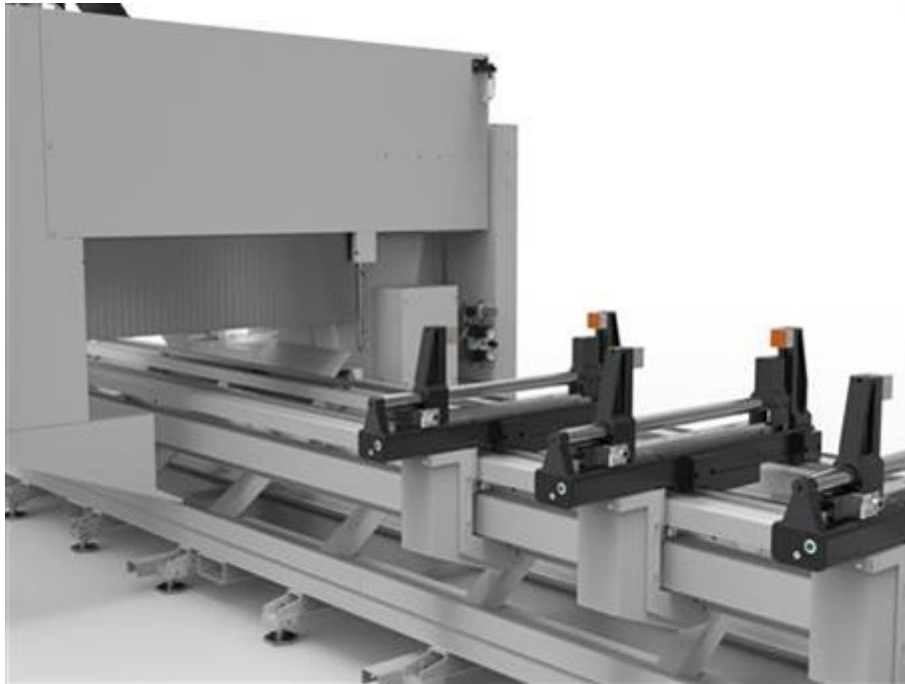

## Stops

A fixed position, pneumatically tilting stop is provided on the left hand side. On request a second fixed position, tilting stop is available on the right hand side for two phase machining of profiles with a length greater than the longitudinal stroke of the CNC or to carry out “pendular” machining or allow the operator to load/unload profiles in masked time. A central stop with controlled movement is available for pendular and multi piece machining operations, to optimise the dimensions of the two working areas.

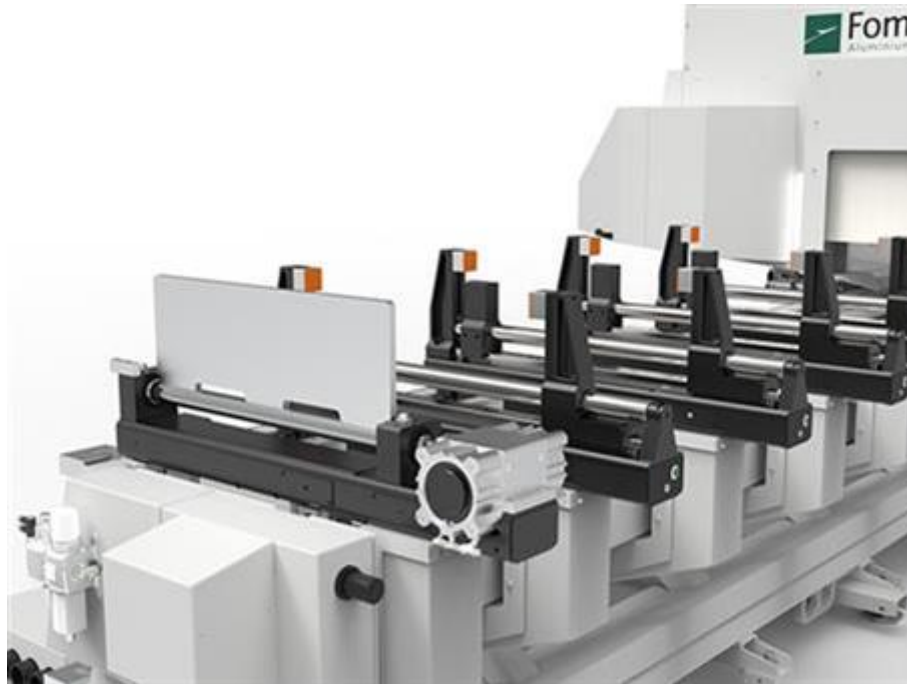

## Electric cabinet

Equipped with filters for protection against emission and reception disturbances (EMO); it is separate from the command console and contains the machine drives, the static frequency changer (inverter), the Power M numeric control complete with the machine control devices, the cooling system; it also has an IP 55 protection grade against dust and liquids.

## Protection and safety devices

The CNC machining centre bears the CE symbol in compliance with the content of Directive 2006/42/CE (Machine Directive). The design and construction of the machining centre complies with the safety regulations in force in the European Union and in the main industrialised countries (USA, Canada, etc). In particular, for the European Union market the following legal provisions are complied with: Directive 2006/42/CE (Machine Directive), Directive 2006/95/CE (LVD) and Directive 2004/108/CE (EMC). The machining centre is also equipped with special safety devices designed to comply with the relevant product standards and the regulations on health and safety in the workplace:

Head guard system on which the electrospindle is installed with an interlocked front guard door.  
Mechanical cams and safety micro switches for operator protection during pendular machining phases.  
Photoelectric cell barrier  
Rear and lateral fences and swinging gate



The electrical system has been engineered in compliance with the provisions contained in European Union directives 2006/95/CE (LVD), 2004/108/CE (EMC) and conforming to the applicable standards governing the safety of electrical systems (EN 60204-1, EN 61000-6-2 and EN 61000-6-4). Special care has been given to the provision of emergency cables and to the system for activating and resetting them. If any faults occur, the operator is alerted by light signals and messages on the monitor. In the event of faults or breakdown, the protection devices inside the panel are designed to prevent injury to persons and/or damage to the machining centre itself.

If for any reason the interaction between the CNC machining centre and the environment in which it is installed contravenes any of the above mentioned conditions, it will be essential to agree with the purchaser a comprehensive solution for achieving the necessary safety conditions so that the purchaser can make the area designated for installing the machining centre suitable and safe.



## CONTROL CONSOLE

Compact control console mounted on wheels for executing programs.



### Technical specifications:

Mobile control console  
24" Display  
Touch screen monitor  
Standard mouse and keyboard  
CN box Power-Family

### PC comprising of:

Solid state hard disk  
2 Net interfaces  
USB ports  
3-year international "on site" warranty for commercial PC

Software installed:

Windows 10 operative system

FST CAM 4

FST MI for managing the working lists and blocks of manual control and service on line – assistance.

Some of the main functions of the software:

Parametric programming

Machining optimizations

Dynamic display of the machining operations

Graphic display of the working area

## FST CAM 4 graphic interface

Graphic interface based on the Windows operating system for planning the machining operations and the pieces which automatically generates the CNC program that can be executed by the machining centre.



Program features:

Display of the workpiece and machining operations in a CAD 3D environment

Profile cross-section display in DXF format

3D display of tool archive

Machining optimizations

Dynamic display of the machining operations

Graphic display of the working area

Simplified management of machining process sequence

Display of technical features of pieces and tools

Graphic user interface

Parametric machining management

Creation of repeated machining operations

Automatic calculation of optimal vice positioning

Machining lists management

Graphic interface for numeric control management

Module for rigid tapping and chase tapping

FSTCAM4 module to design and manage special clamping operations (on request, PIC. 3)

Flow drilling management (on request)

Module for insertion of "user defined" geometries by importing the shape of the machining operation from DXF format files, for FST CAM 4 (on request)

Wireless bar-code reader + data import software in accordance to FOM protocol (on request)

## Remote Assistance

Used to check the machine data, the user programmes, the input/output signals and system variables in real time, providing a rapid solution to problems and a drastic reduction in machine stoppage. Thanks to remote assistance it is also possible to install updated software versions. The machining centre is enabled for this type of service. The duration of the service is limited to the machining centre warranty period.

## Maintenance equipment

The following are supplied with the machining centre:

Tool holder locking device for insertion/removal of tools

Set of wrenches

## Turnkey System

FOM INDUSTRIE not only offers its Clients a machine tool, but also a "turnkey" productive system to solve all of the problems involved in production. The company's experience is at the client's disposition to optimise the relationship between machining centre performance and the technological machining requirements, the service relies on:

A CAD-CAM system for creating a project which provides for piece design, automatic creation of the program and simulation of the machining operations

A vast archive of projects created for companies operating in important industrial sectors (automotive, railways, naval, furniture, transport, aeronautic, textile)

Facilitated contacts with the most important and qualified suppliers of tools and equipment

## Standard configuration:

- Electrospindle 22 kW (S1) 24.000 rpm (HSK E63) with liquid cooling system
- 15 – position tool magazine; suitable for  $\varnothing$  400 mm. blade (HSK 63) and angular system
- Pneumatic vices with NC independent positioning:
  - AXEL 4 - 075: No. 4 vices
  - AXEL 4 - 100: No. 6 vices
  - AXEL 4 - 150: No. 8 vices
- Left sliding pneumatic stop
- Head guard protecting the working area.
- Minimum quantity lubrication (MQL) with pure oil
- Automatic lubrication for all in motion parts
- Central automatic greasing system and device for manual greasing
- Photoelectric cell barrier.
- Rear and side fences and swinging gate
- Machine handling kit
- Control equipment: POWER-M
- Mobile control console with PC, 24" touch screen monitor, mouse and keyboard
- Software licence for tapping cycle
- FSTCAM4 software 3/4 axes version
- FST CAM 4 training course (FOM premises)

## Technical specifications:

Working area with direct tool L=140 spindle end and with tools L=30 on 2-output angular unit		
Axis X (AXEL 4 075)	top face only	mm 7675
Axis X (AXEL 4 075)	top face + ends	mm 7535
Axis X (AXEL 4 100)	top face only	mm 9835
Axis X (AXEL 4 100)	top face + ends	mm 9695
Axes Y and Z	for machining on 2 faces of profile	mm 580 x 360
Axes Y and Z	for machining on 3 faces of profile	mm 520 x 360
Axis A		-15° ÷ +195°
Dynamic performance		
Axis X	Speed	m/min 90
Axis Y	Speed	m/min 75
Axis Z	Speed	m/min 60
Axis A	Speed	°/min 12,000
Profile positioning and locking		
Vices with automatic positioning along the X-axis (longitudinal) (AXEL 4 075)		n. 4 as standard
Vices with automatic positioning along the X-axis (longitudinal) (AXEL 4 100)		n. 6 as standard
Max number of vices (AXEL 4 075)		8
Max number of vices (AXEL 4 100)		10
Transformation of standard vices to vices with independent positioning		standard
Pair of vices with independent positioning		optional
Automatically reclining fixed stop		n. 1 standard + 1 optional
Central mobile stop for pendular multi piece machining operation		optional
SW adjustment of the vice pressure		standard
Electrospindle		
Tool coupling		HSK E63
SW Module for rigid tapping		standard
Cooling		Liquid
22 kW (S1) 24.000 rpm electrospindle		standard
Lubrication of mechanical components		
Automatic lubrication of straight guide blocks and recirculating ball screw lead screws		standard

### Tool magazine

15-Position tool magazine mounted on the head		standard
Tool replacement time		s 6
Maximum tool weight		Kg. 6
Maximum blade diameter in the magazine (head mounted)		mm 260
Maximum blade diameter in the magazine (horizontal)		mm 400
Maximum tool length in the magazine		mm 195 (Ø 80)
Device to measure tool length		optional

### Tool lubrication

Minimum quantity lubrication		standard
Lubrocooling with minimum use of water-oil		optional
4 nozzles integrated into the head		standard

### Chips, waste and fumes removal

Chip and waste collection in base		standard
Hinged belt conveyor with ramp		optional

### Control and software

Control pushbutton panel		standard
Wireless remote-control push-button panel		optional
Carriage-mounted control console		standard
23 screen		standard
USB ports		1 console + 3 in the PC
SSD		256 GB
Memory		8 GB
Wireless bar-code reader		optional
Software		Windows 10 - FST CAM 4
Numerical control type		POWER M

## Possible work area configurations (on request):

PENDULAR MACHINING (2 working areas, 2 pieces) for AXEL 4 075 and 100

- Pair of additional pneumatic vices with independent positioning
- Right pneumatic fixed stop
- Software to manage pendular machining
- Safety devices for pendular machining

PENDULAR MACHINING (2 working areas, 2 pieces) for AXEL 4 075 and 100

- 2 pairs of additional vices
- Right pneumatic fixed stop
- Software to manage pendular machining
- Safety devices for pendular machining

PENDULAR MULTI PIECE MACHINING for AXEL4 075 (2 working areas, 4 pieces):

- 2 pairs of additional pneumatic vices with independent positioning
- Right pneumatic fixed stop
- Central pneumatic fixed stop
- Software to manage pendular machining
- Safety devices for pendular machining

PENDULAR MULTI PIECE MACHINING for AXEL4 100 (2 working areas, 4 pieces):

- 1 pair of additional pneumatic vices with independent positioning
- Right pneumatic fixed stop
- Central pneumatic fixed stop
- Software to manage pendular machining
- Safety devices for pendular machining

CUT AND SEPARATE for AXEL 4 075

- Cut and separate module
- Angular unit with blade  $\varnothing$  260

CUT AND SEPARATE for AXEL 4 100

- Cut and separate module
- Angular unit with blade  $\varnothing$  260

CUT AND SEPARATE for AXEL 4 075

- Cut and separate module
- 1 pair of additional vices
- Angular unit with blade  $\varnothing$  260

CUT AND SEPARATE for AXEL 4 100

- Cut and separate module
- 1 pair of additional vices
- Angular unit with blade  $\varnothing$  260

CUT AND SEPARATE for AXEL 4 075

- Cut and separate module
- 2 pairs of additional vices
- Angular unit with blade  $\varnothing$  260

CUT AND SEPARATE for AXEL 4 100

- Cut and separate module
- 2 pairs of additional vices
- Angular unit with blade  $\varnothing$  260

PENDULAR MACHINING + CUT AND SEPARATE for AXEL 4 075

- Cut and separate module
- 1 pair of additional vices
- Angular unit with blade  $\varnothing$  260
- Right pneumatic fixed stop
- Software to manage pendular machining
- Safety devices for pendular machining

PENDULAR MACHINING + CUT AND SEPARATE for AXEL 4 100

- Cut and separate module
- 1 pair of additional vices
- Angular unit with blade  $\varnothing$  260
- Right pneumatic fixed stop
- Software to manage pendular machining
- Safety devices for pendular machining

PENDULAR MACHINING + CUT AND SEPARATE for AXEL 4 075

- Cut and separate module
- 2 pairs of additional vices
- Angular unit with blade  $\varnothing$  260
- Right pneumatic fixed stop
- Software to manage pendular machining
- Safety devices for pendular machining

PENDULAR MACHINING + CUT AND SEPARATE for AXEL 4 100

- Cut and separate module
- 2 pairs of additional vices
- Angular unit with blade  $\varnothing$  260
- Right pneumatic fixed stop
- Software to manage pendular machining
- Safety devices for pendular machining

PENDULAR MULTI PIECE MACHINING + CUT AND SEPARATE for AXEL 4 075

- Cut and separate module
- 2 pairs of additional vices
- Angular unit with blade  $\varnothing$  260
- Right pneumatic fixed stop
- Central pneumatic fixed stop
- Software to manage pendular machining
- Safety devices for pendular machining

PENDULAR MULTI PIECE MACHINING + CUT AND SEPARATE for AXEL 4 100

- Cut and separate module
- 1 pair of additional vices
- Angular unit with blade  $\varnothing$  260
- Right pneumatic fixed stop
- Central pneumatic fixed stop
- Software to manage pendular machining
- Safety devices for pendular machining



## Optionals:

- Additional charge for special power supply with transformer
- Additional charge for electrical version UL-CSA
- Additional charge for electric cabinet cooling
- Additional charge for EAC (Eurasian Conformity) certification
- Additional pneumatic clamps with NC independent positioning (nr. 2)
- Touch probe
- Piece temperature detection probe
- Additional charge for head cover on top with internal lighting and smoke collectors prearrangement.
- Laser device to check the integrity and measure the length of the tool with relevant software
- Lubrocooling
- Flowdrill (for steel, not suitable if the profiles are already galvanised)
- Mechanical chip conveyor belt
- Machine handling by container
- Fume extractor
- Integral guard system (roof) with internal lighting
- Licence for FST CAM 4 program for office
- Additional licence for FST CAM 4 program for office
- 2D custom milling Module for FST CAM 4
- SOLID PLUS software licence (3+1 or 4 axis CNC machining centres)
- SOLID PLUS additional software licence (3+1 or 4 axis CNC machining centres)
- Wireless bar-code reader + data import software for data in accordance to FOM protocol (ZP712762)
- • SW to import FOM protocol-compatible data
- Data conversion driver
- Wireless remote-control push-button panel (controlled by radio)
- Label printer
- Software licence for "Clock", module for times calculation for FST CAM
- Software licence for data import in ISO format
- Software licence for data import in NCX format
- Angular head for machining on the underneath side of the profile (HSK63)
- Angular unit, blade  $\varnothing$  260 mm included Z=70 thickness 4 mm
- HSK E63 heads double machining output angular head unit
- HSK E63 parallel bars double machining output angular head unit
- TOOL SET TYPE C1 (HSK63) for aluminium:
  - N° 1 collet  $\varnothing$  5/6 ER 32 (DR-75897)
  - N° 1 collet  $\varnothing$  7/8 ER 32 (DR-75899)
  - N° 2 collet  $\varnothing$  9/10 ER 32 (DR-75901)
  - N° 1 collet  $\varnothing$  11/12 ER 32 (DR-76038)
  - N° 5 collet holder HSKE63 L70 ER32 (DR712809)
  - N° 1 milling bit  $\varnothing$  5 L50 K10 Z=1 TIALN (HZ-43794)
  - N° 1 milling bit sgr. MD  $\varnothing$  10 L90 Z1 TIALN (HZ325308)
  - N° 1 milling bit  $\varnothing$  12 L83 K10 Z1 TIALN (HZ-43799)
  - N° 1 single flute milling cutter  $\varnothing$  5/10 L68 (STEEL) (HZ-45283)
  - N° 1 milling bit sgr. MD  $\varnothing$  8 L80 Z1 TIALN (HZ-47899)
  - Sawblade  $\varnothing$  400 mm and tool-holder cone (HSK63)
  - Sawblade for iron  $\varnothing$  335 mm thk. 2,2 mm and tool-holder (HSK63)