

Smith Machine JL006

-

Assembly Instruction

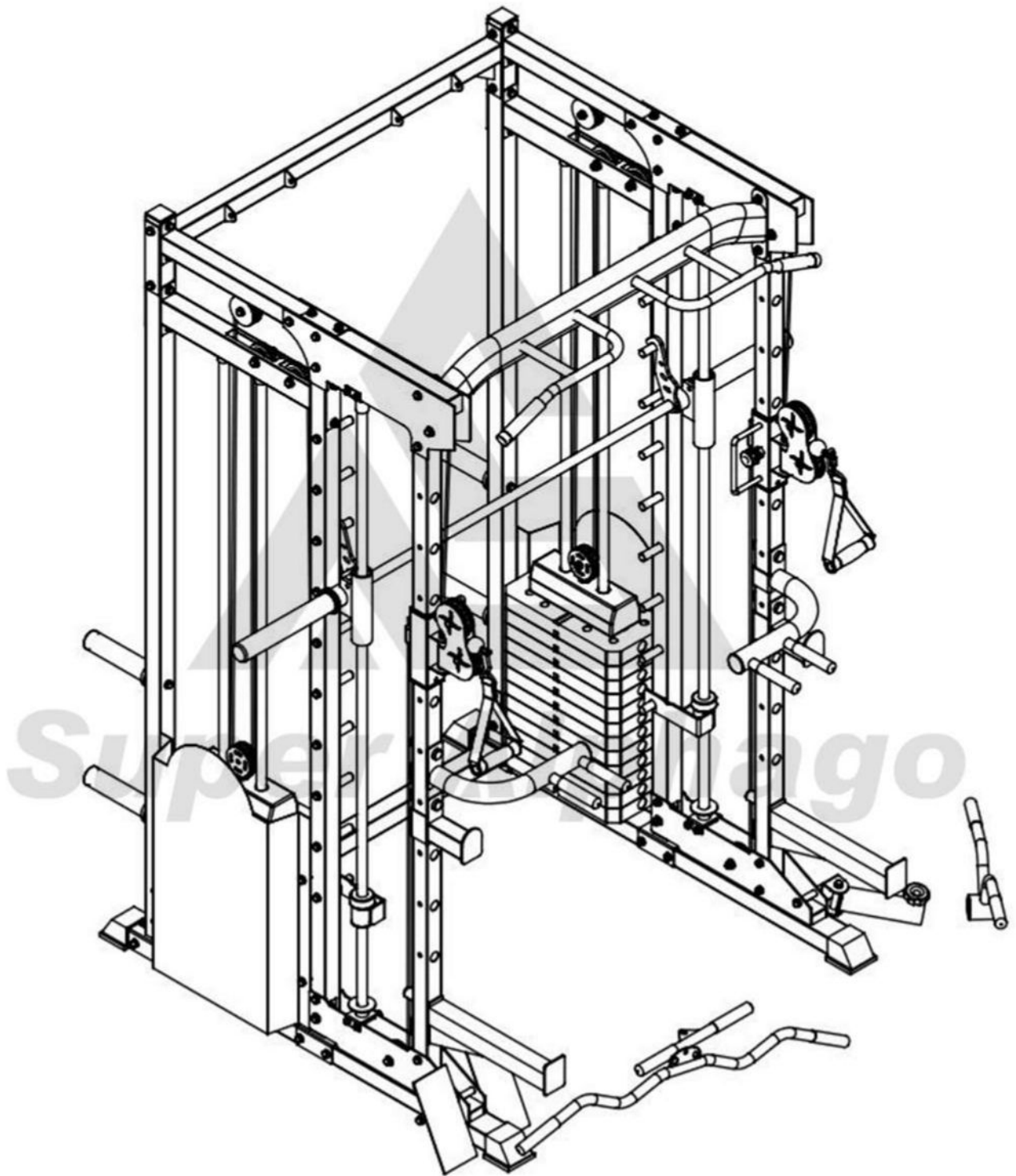

Safety Precautions

In order to ensure your safety, please read the following note

1. Please read Safety Precautions before using it. Study and understand the instructions and all warning labels are necessary.

(It is recommended to be familiar with the normal operation and use of the device before using this product. Relevant information is available in this specification and local retailers)

2. Please keep this specification, and ensure that all warning labels are clear and complete .

3. This product recommends that more than two people install.

4. Please consult your doctor for advice if it is for rehabilitation training.

5. Before you start exercising. Please ensure you keep children away from this product.

6. Please check all cables regularly. And do not use if there is any wear and tear, as it may cause a certain risk to you.









































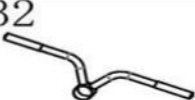































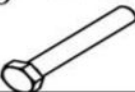





7. Please maintain the extensibility of your hands, limbs, and clothes, so that you can safely use this product.

8. Please pay attention to any possible signs of machinery, including wear and tear of parts, loosening of hardware and welding cracks. If any of the above signs are found, stop using this device immediately and contact our after-sales service department .

9. You can use the internal hexagonal wrench to complete the assembly .

10. Maximum training load of this instrument: 120KG is limited to 100KG body use .

11. The final interpretation of the company is owned by the company, products are subject to change without prior notice

1 	2 	3 	4 	5 
6 	7 	8 	9 	10 
11 	12 	13 	14 	15 
16 	17 	18 	19 	20 
21 	22 	23 	24 	25 
26 	27 	28 	29 	30 
31 	32 	33 	34 	35 
36 	37 	38 	39 	40 
41 	42 	43 	44 	45 
46 	47 	48 	49 	50 
51 	52 	53 	54 	55 
56 	57 	58 	59 	60  数量: 1件 M10旋钮
61 	62 	63 	70 	71 
73 	74 	77 	78 	79 
80 	82 	83 	84 	85 
86 	90 	91 	92 	

74

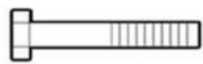

M10X70mm

4

70

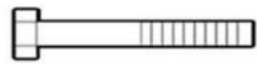

M10X95mm

4

85



Φ 10

16

83



M 10

8

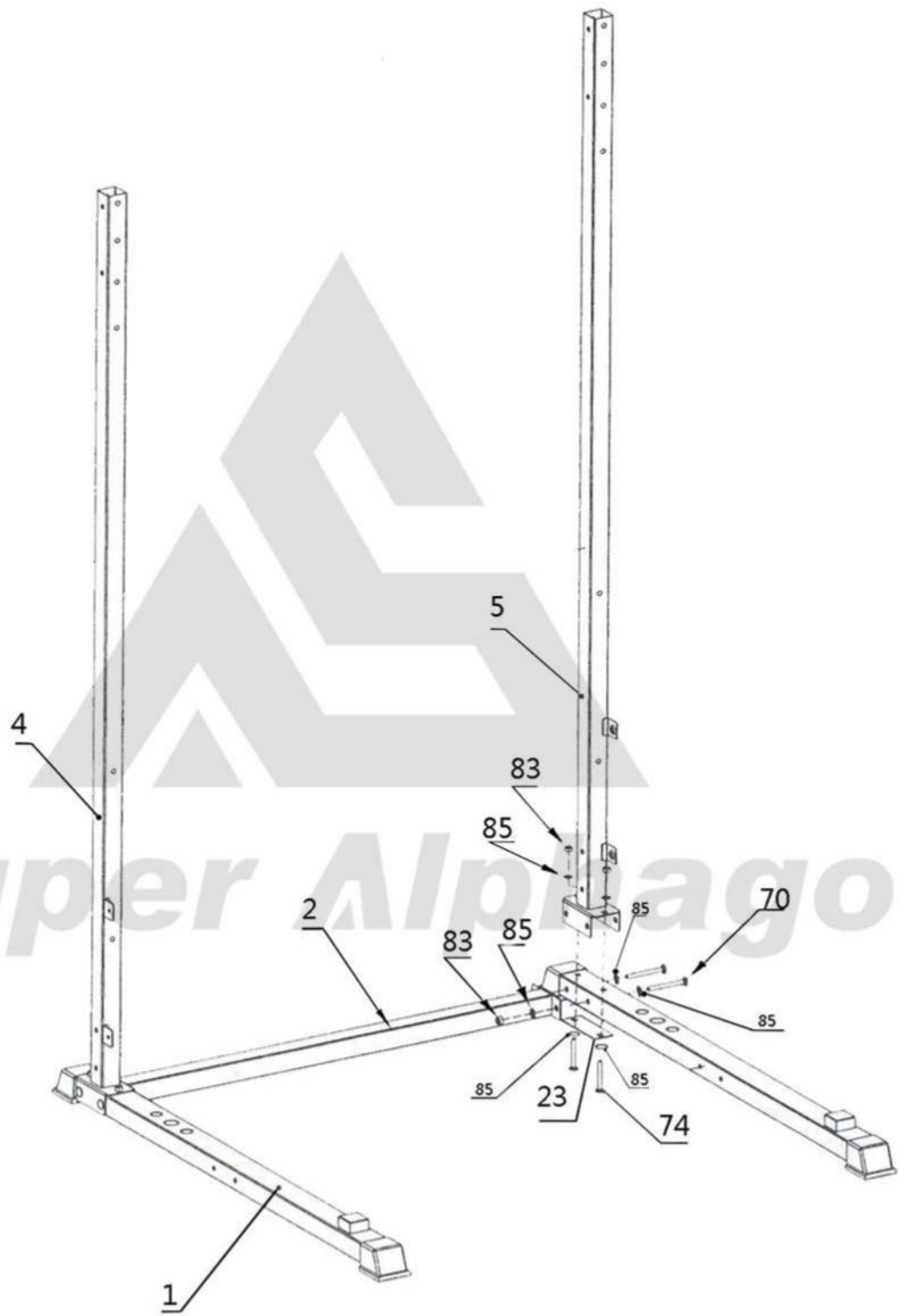

1

1

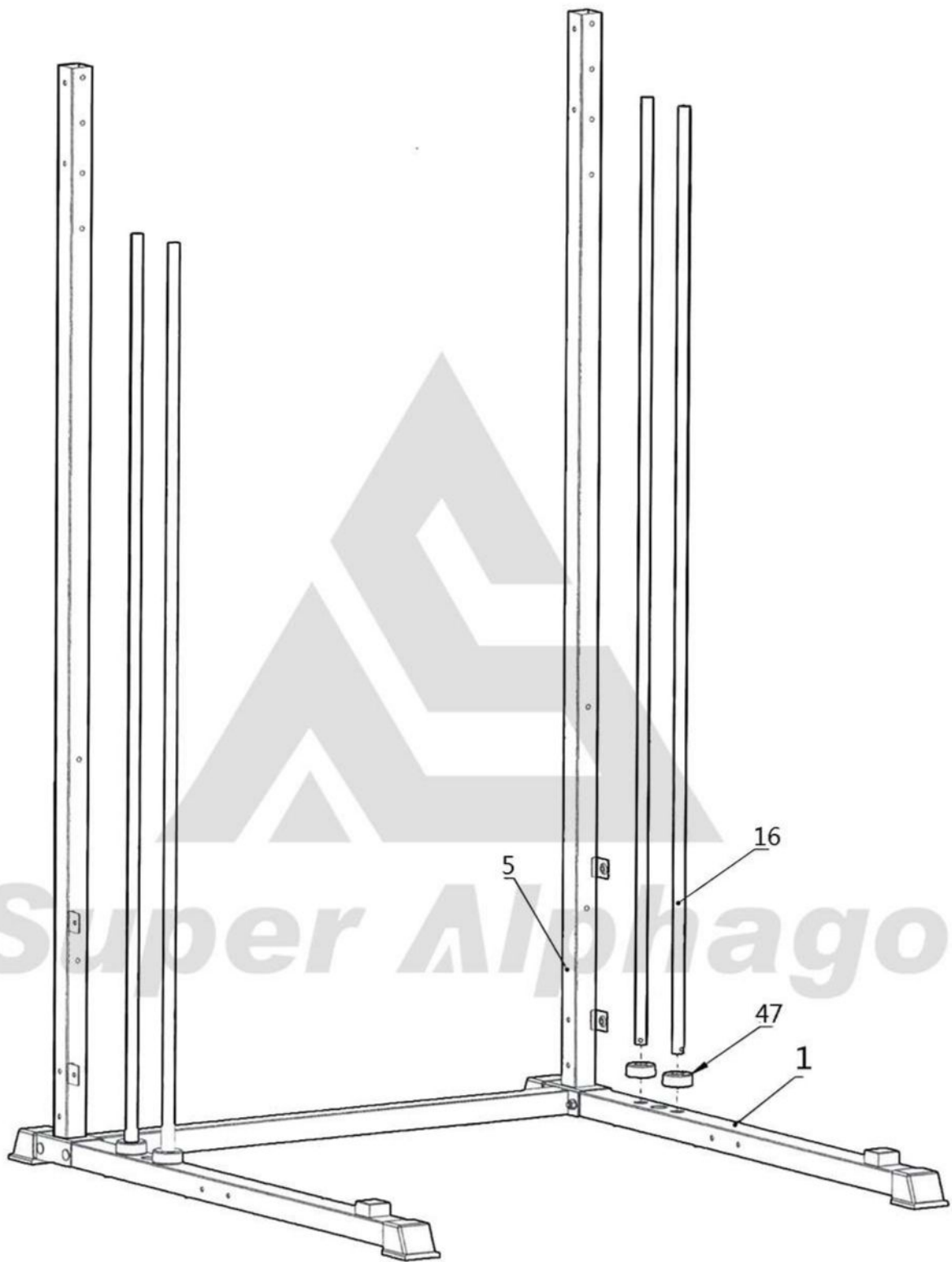

2

71

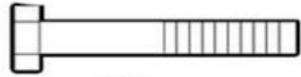

M10X90mm

4

85



Φ10

8

83



M10

4

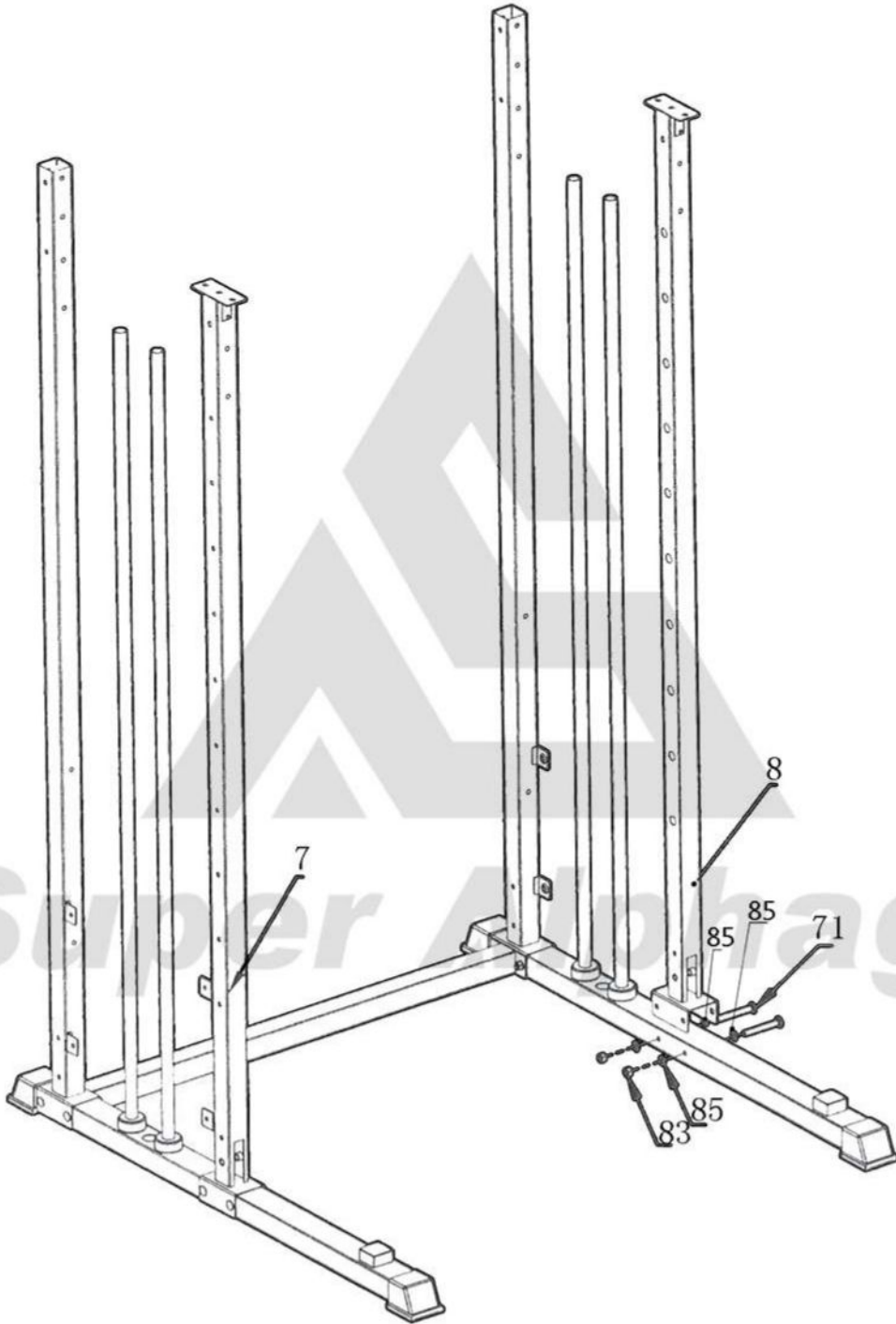

3

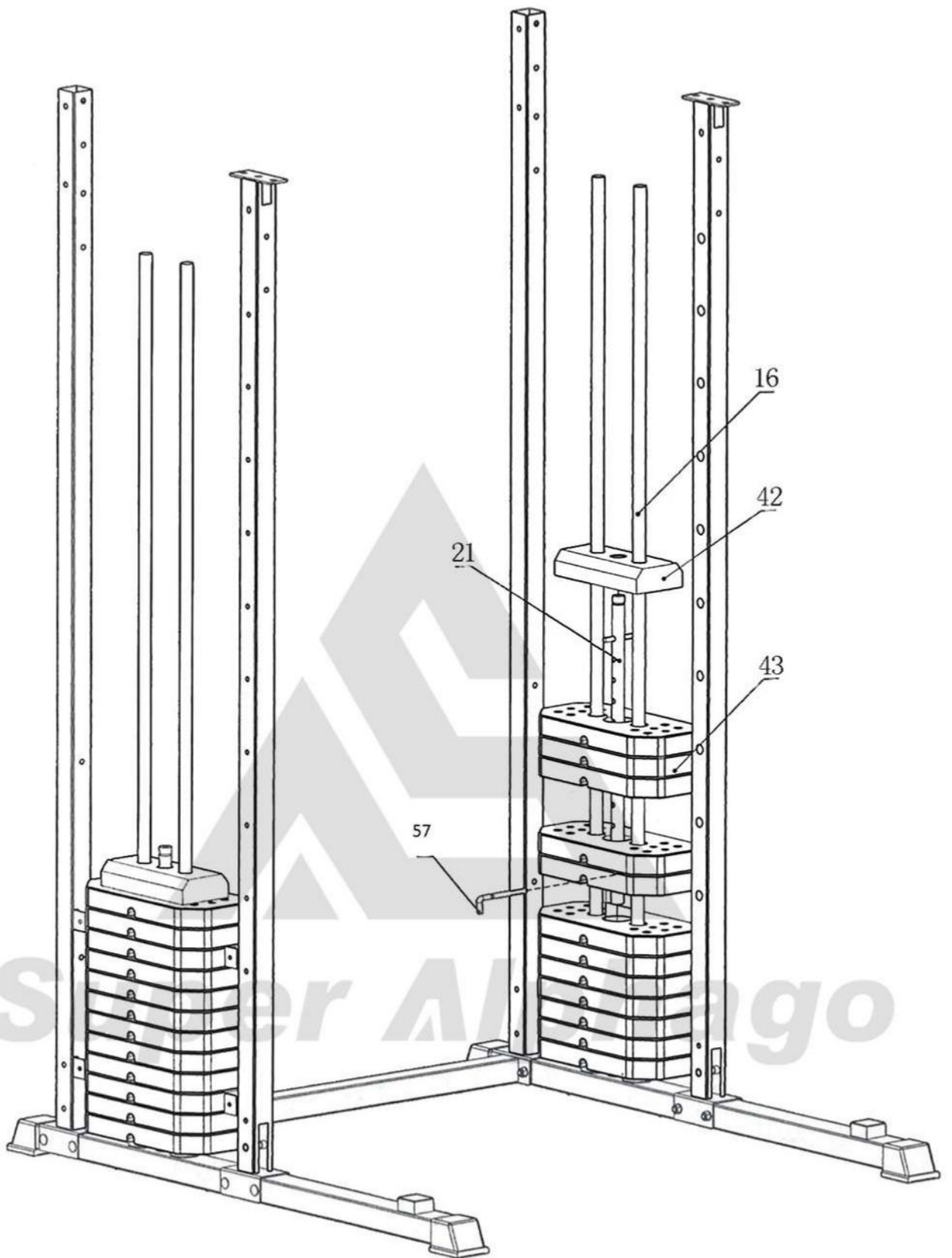

4

74



M10X70mm

4

85



Φ10

8

83



M10

4

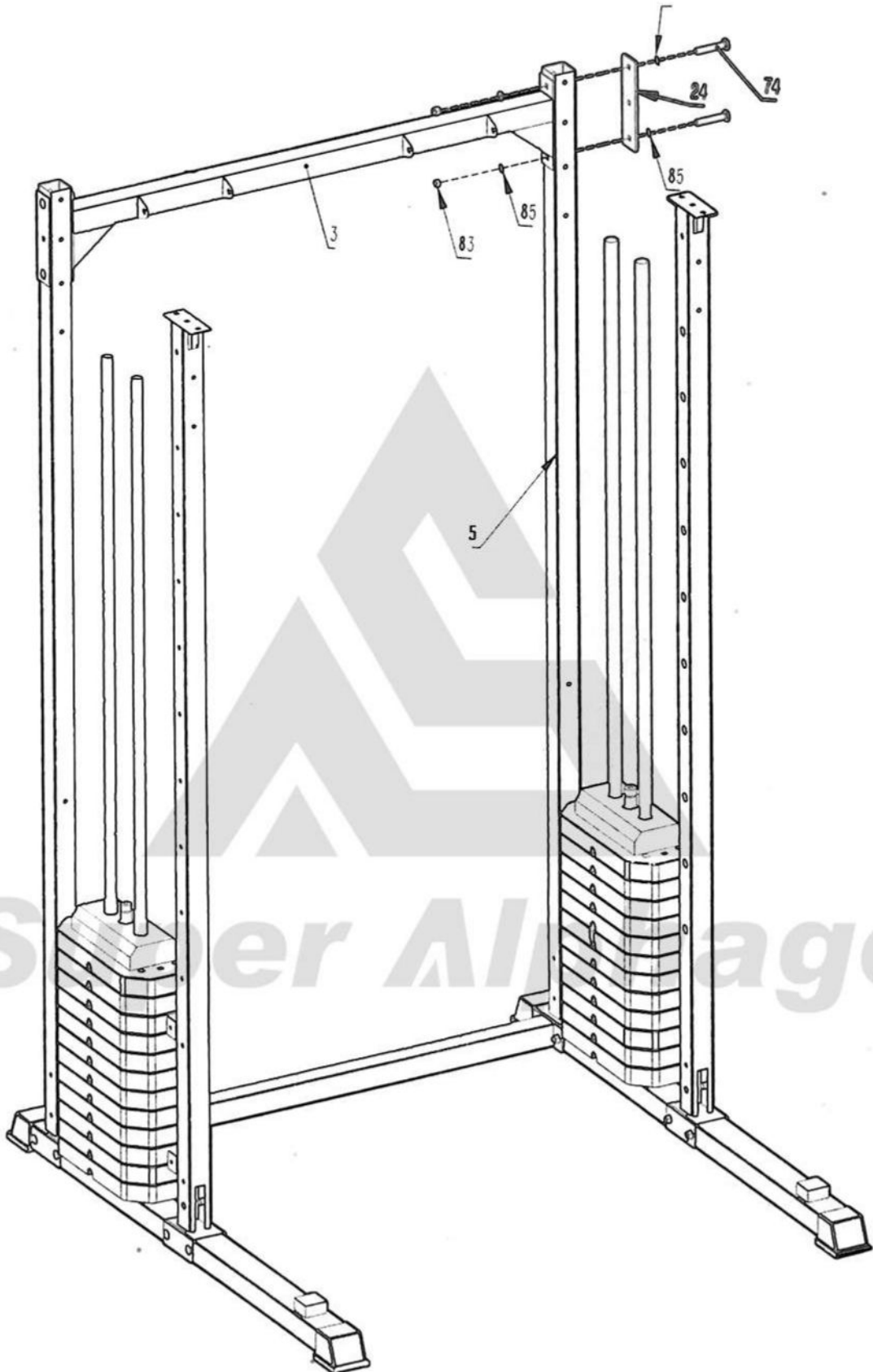

5

- 74
- 79
- 85
- 83

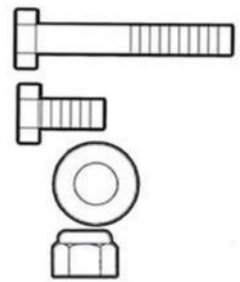

M10X70mm
 M10X15mm
 Φ10
 M10

- 2
- 4
- 8
- 2

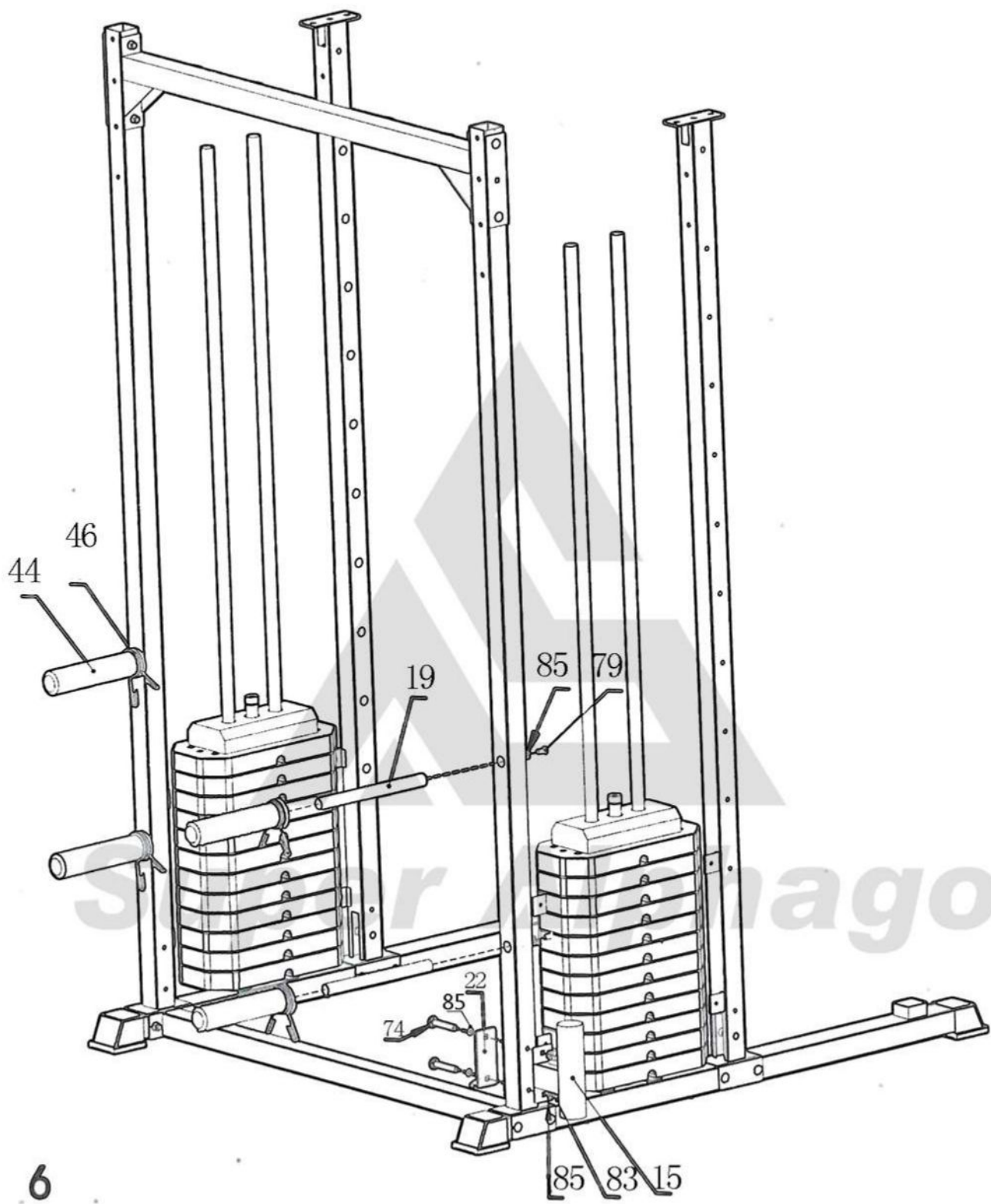

6

- 74
- 82
- 85
- 83

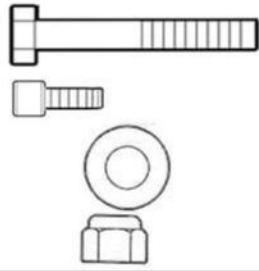

M10X70mm

8

M8X35

4

Φ10

16

M10

8

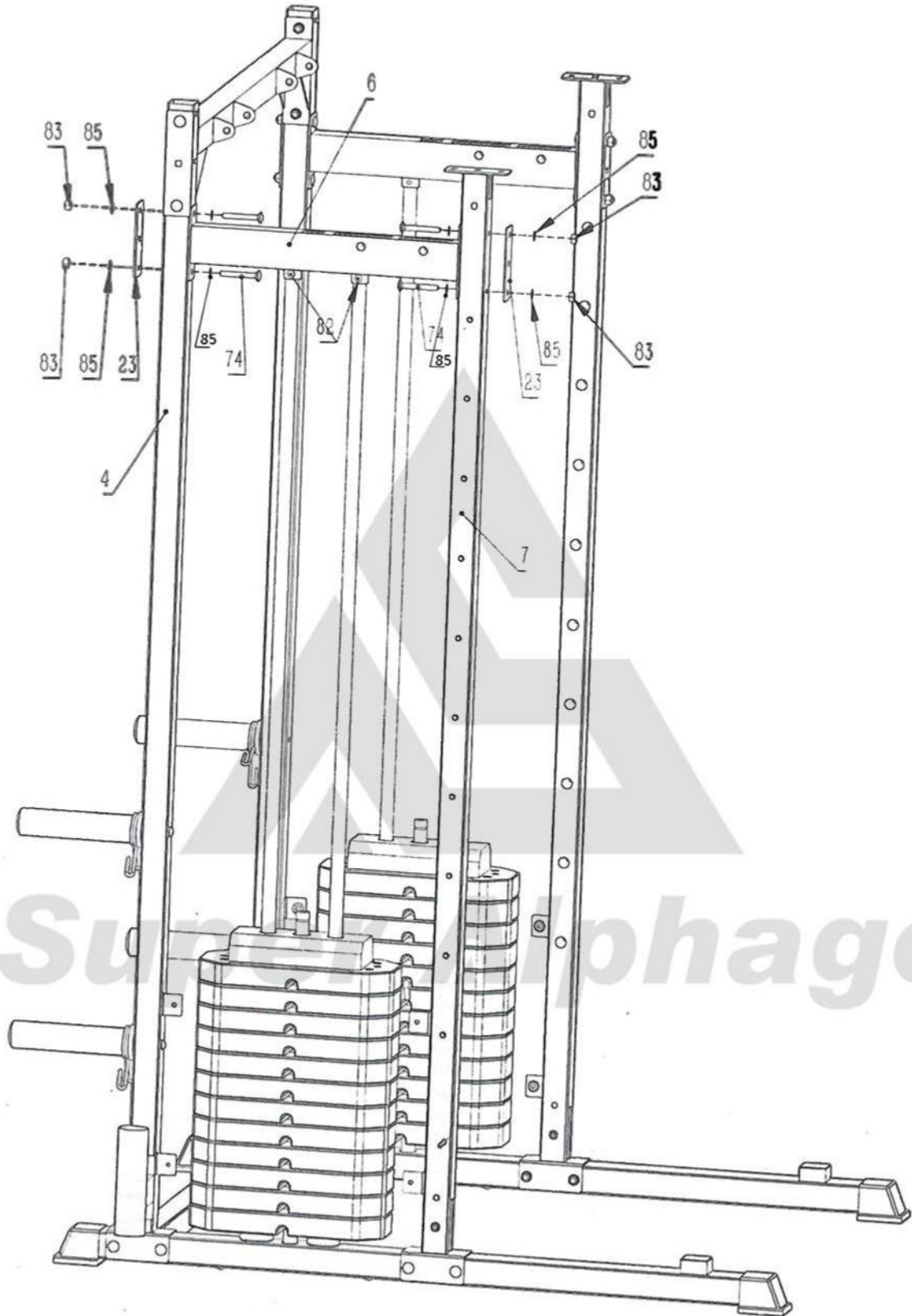

7

74

85

83

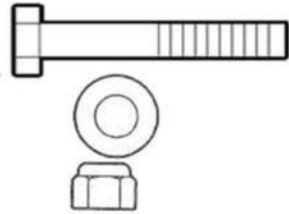

M10X70mm

Φ10

M10

8

16

8

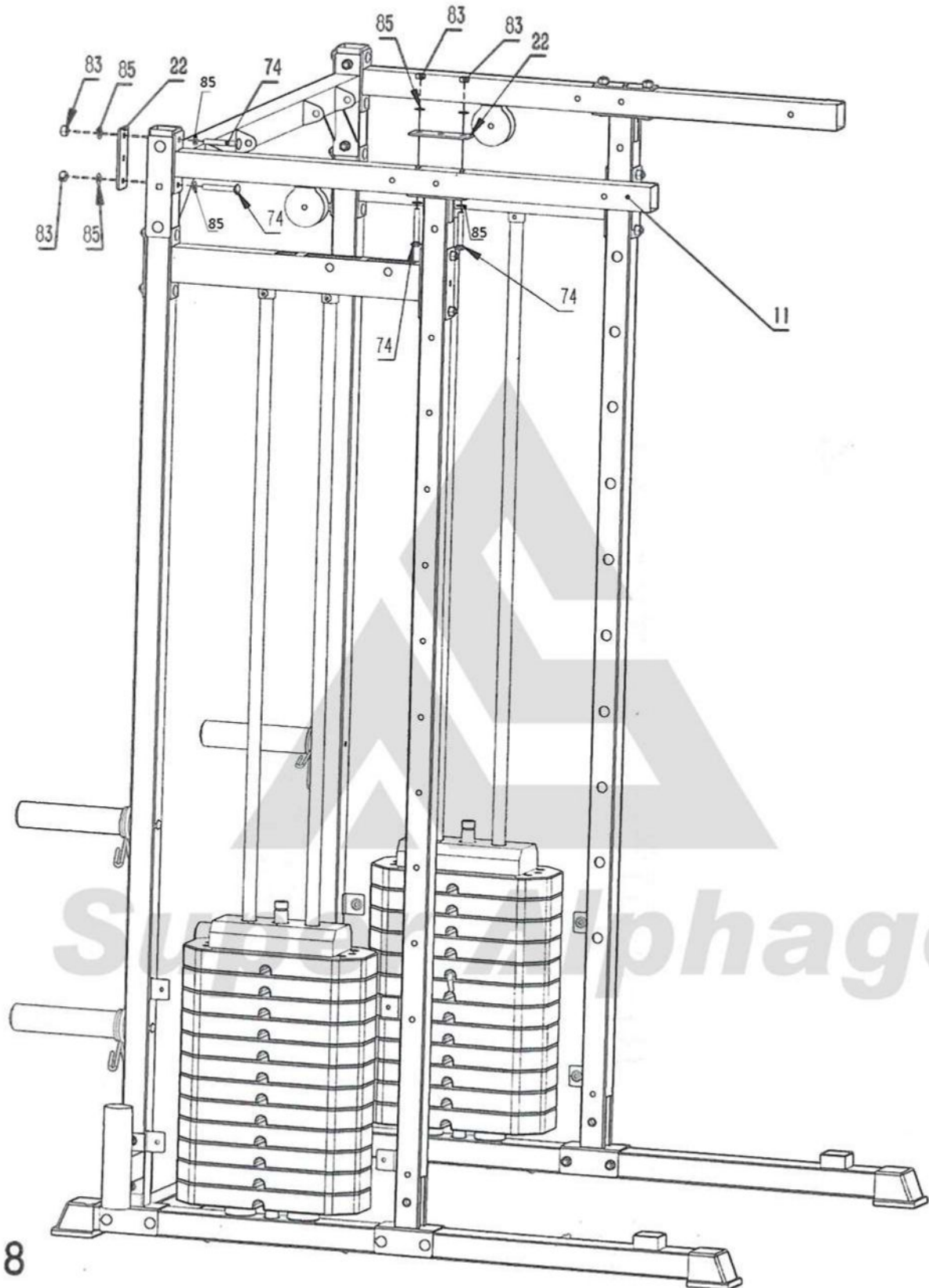

8

74

85

83

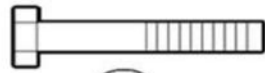

M10X70mm

Φ10

M10

8

16

8

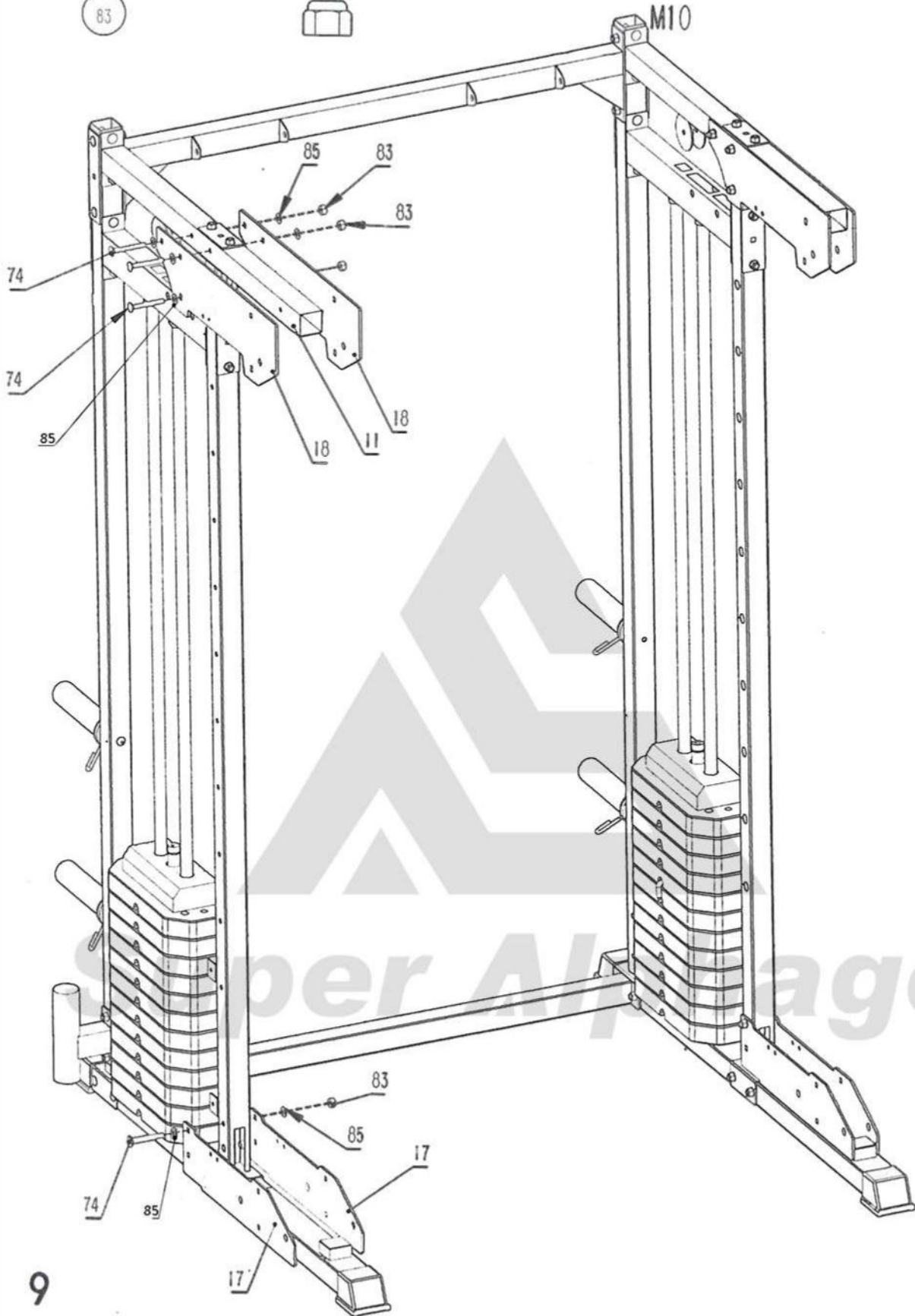

74

85

83



M10X70mm

Φ10

M10

4

8

4

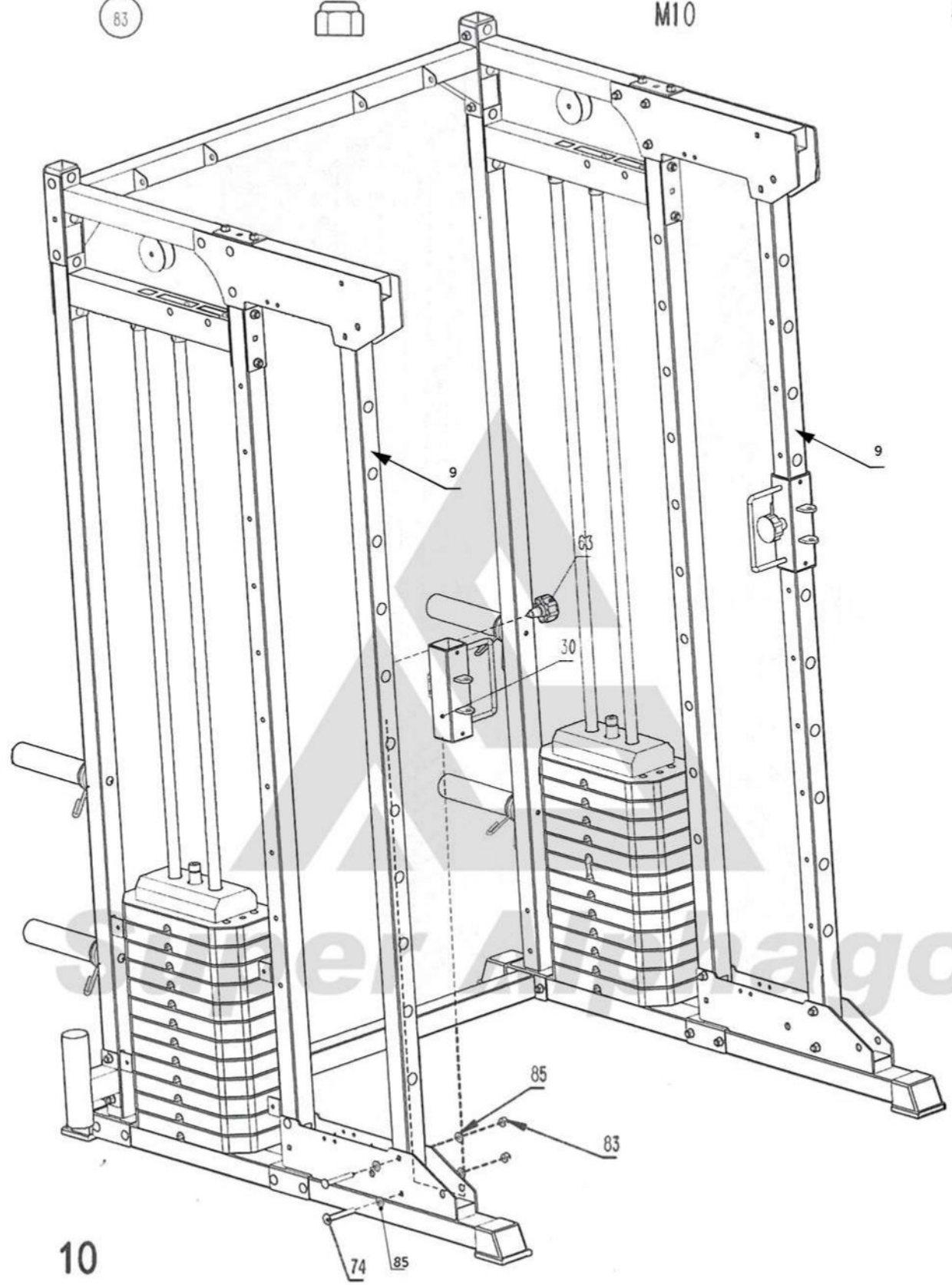

10

73

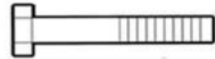

M10X75mm

4

85



Φ 10

12

83



M10

4

79



M10X15mm

4

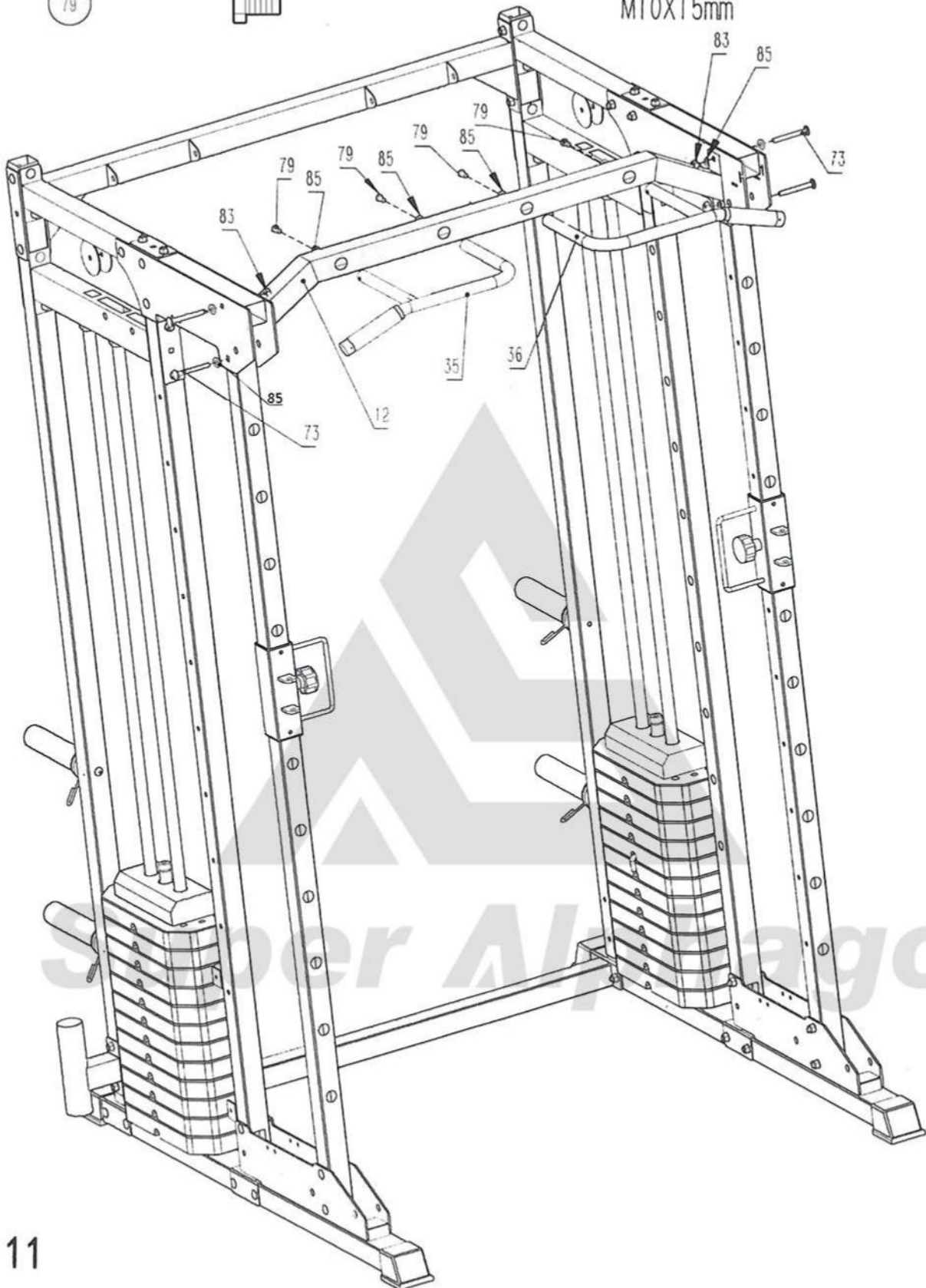

11

80

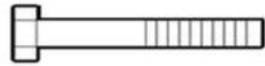

M10X110mm

2

85



Φ10

24

83



M10

2

79

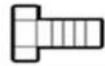

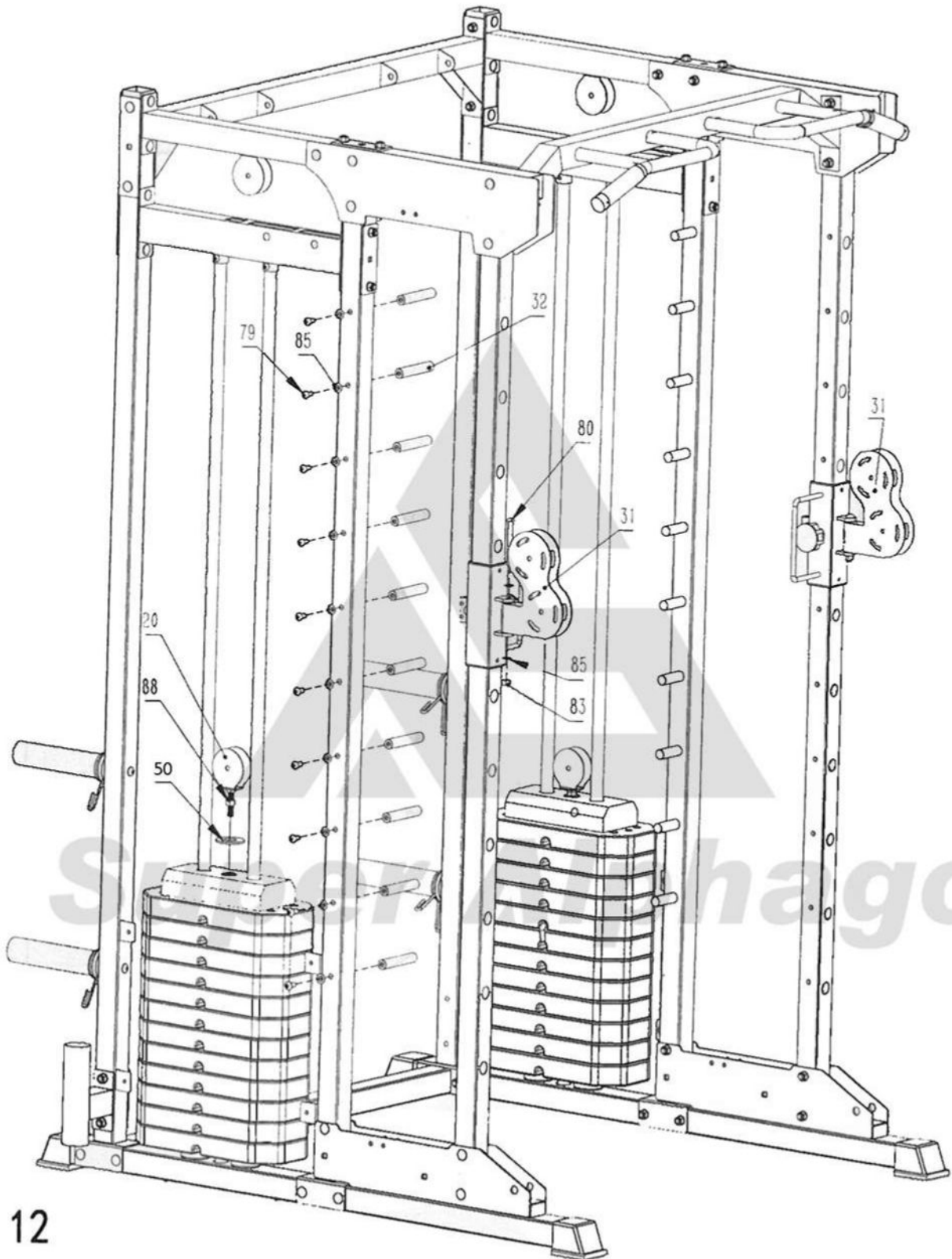

M10X15mm

20

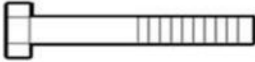

12



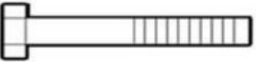
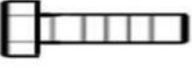

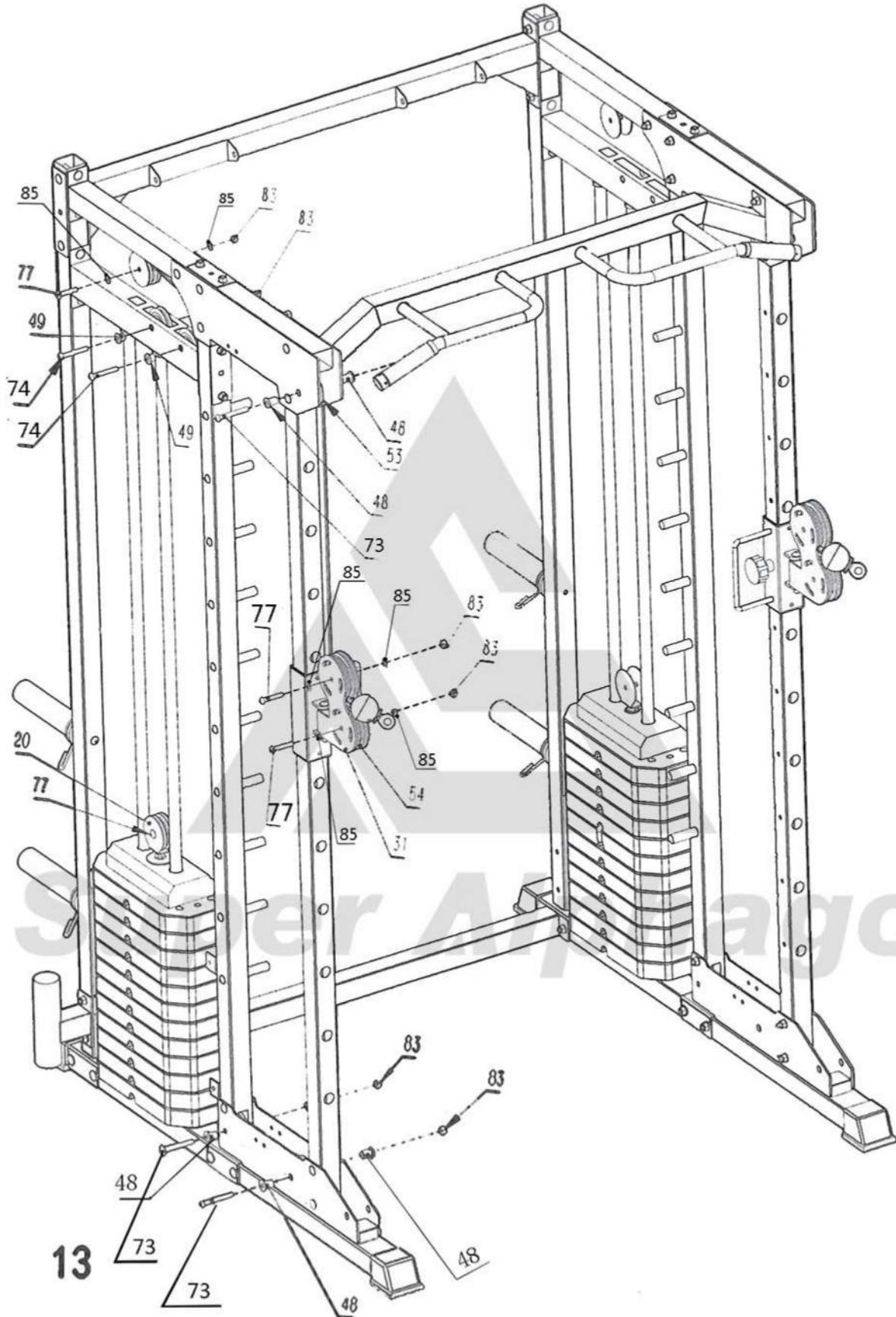

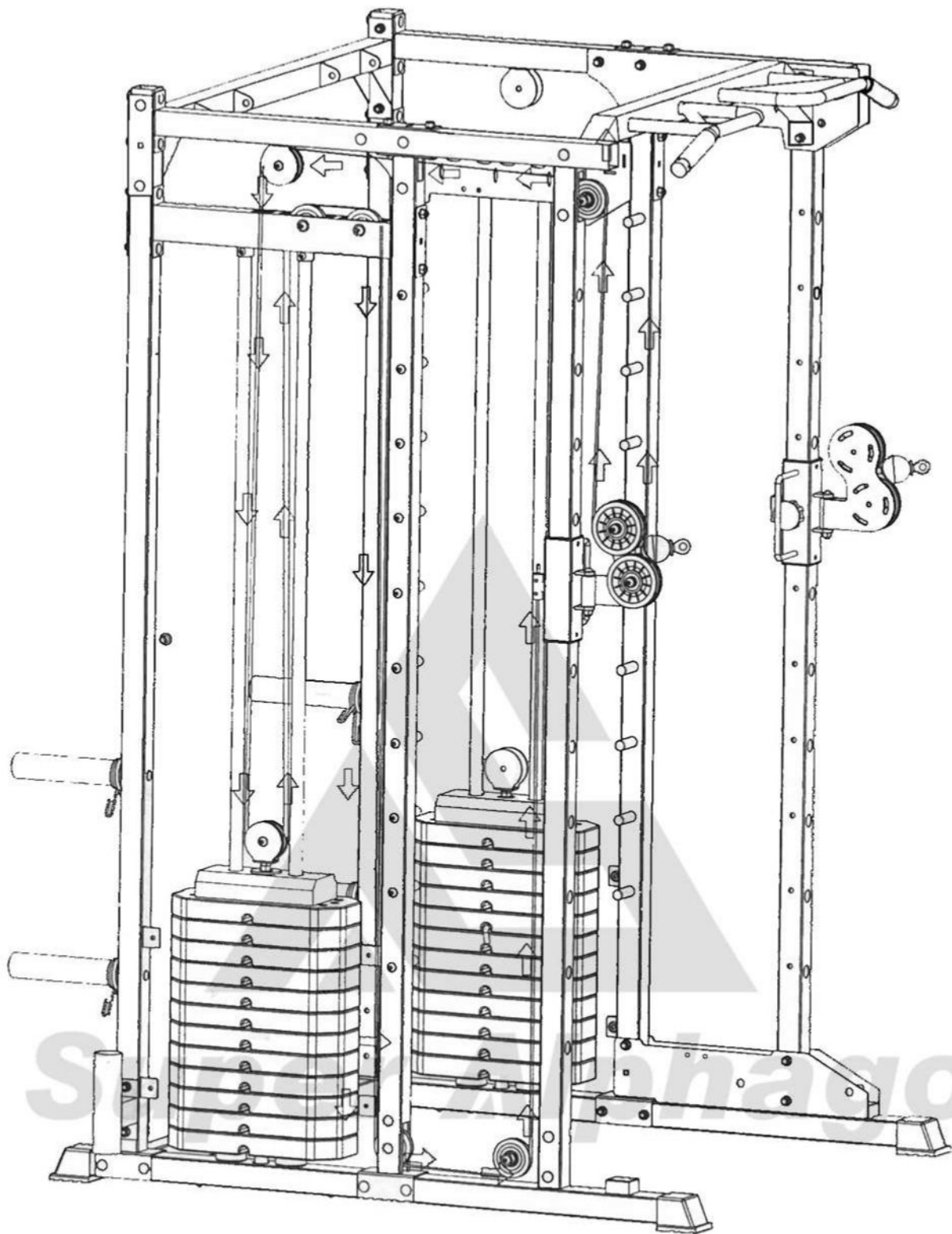
74		M10x70mm	4
85		Φ10	36
83		M10	18

73		M10x75mm	6
77		M10x45mm	8



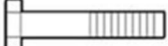

13-1

79		M10X15mm	3	78		M8X16mm	8	71		M10X90mm1	
85		Φ10	5	84		M8	8	83		M10	1
				86		Φ 8	16				

8

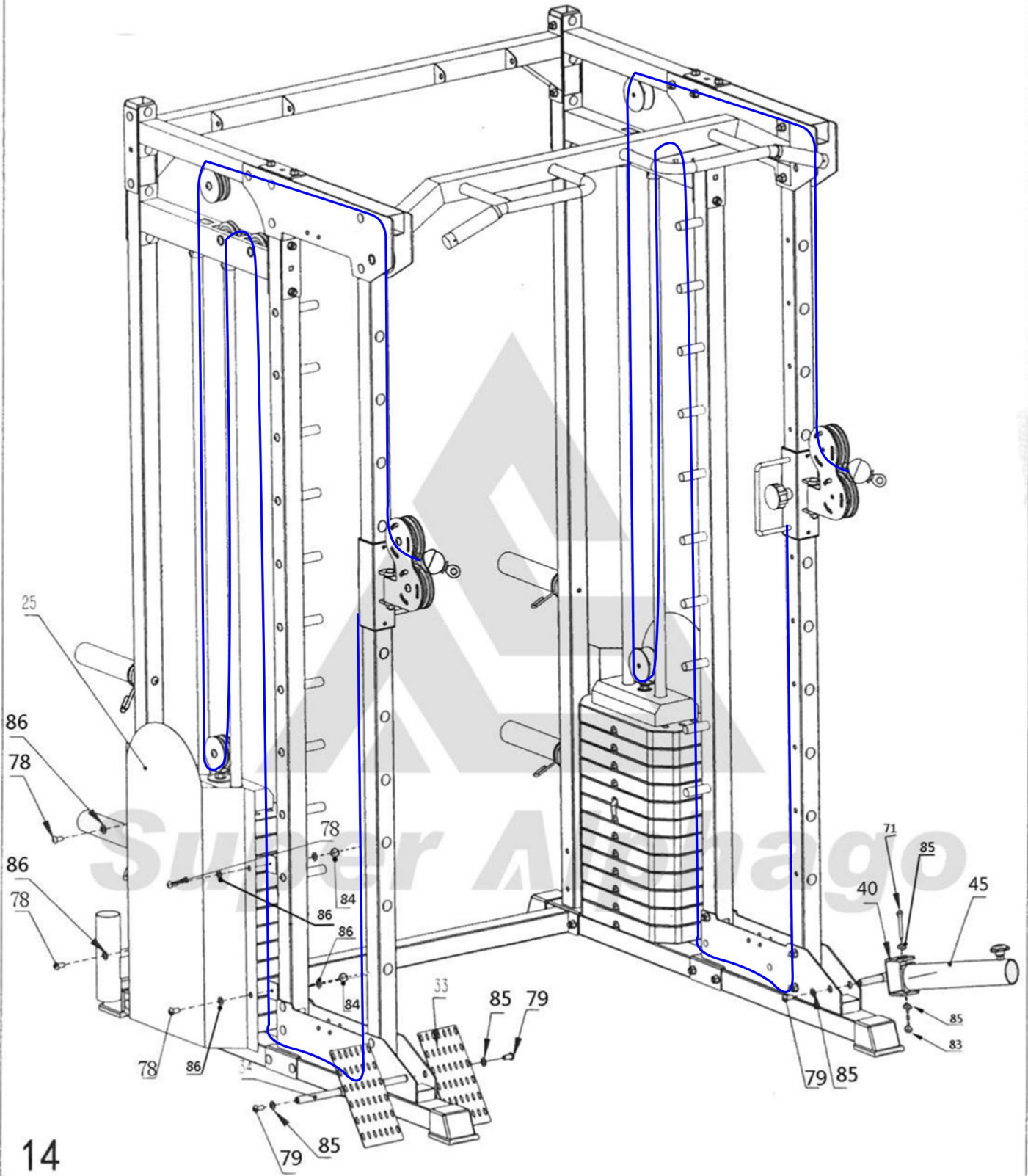

14

79



M10X15mm

2

85



Φ10

2

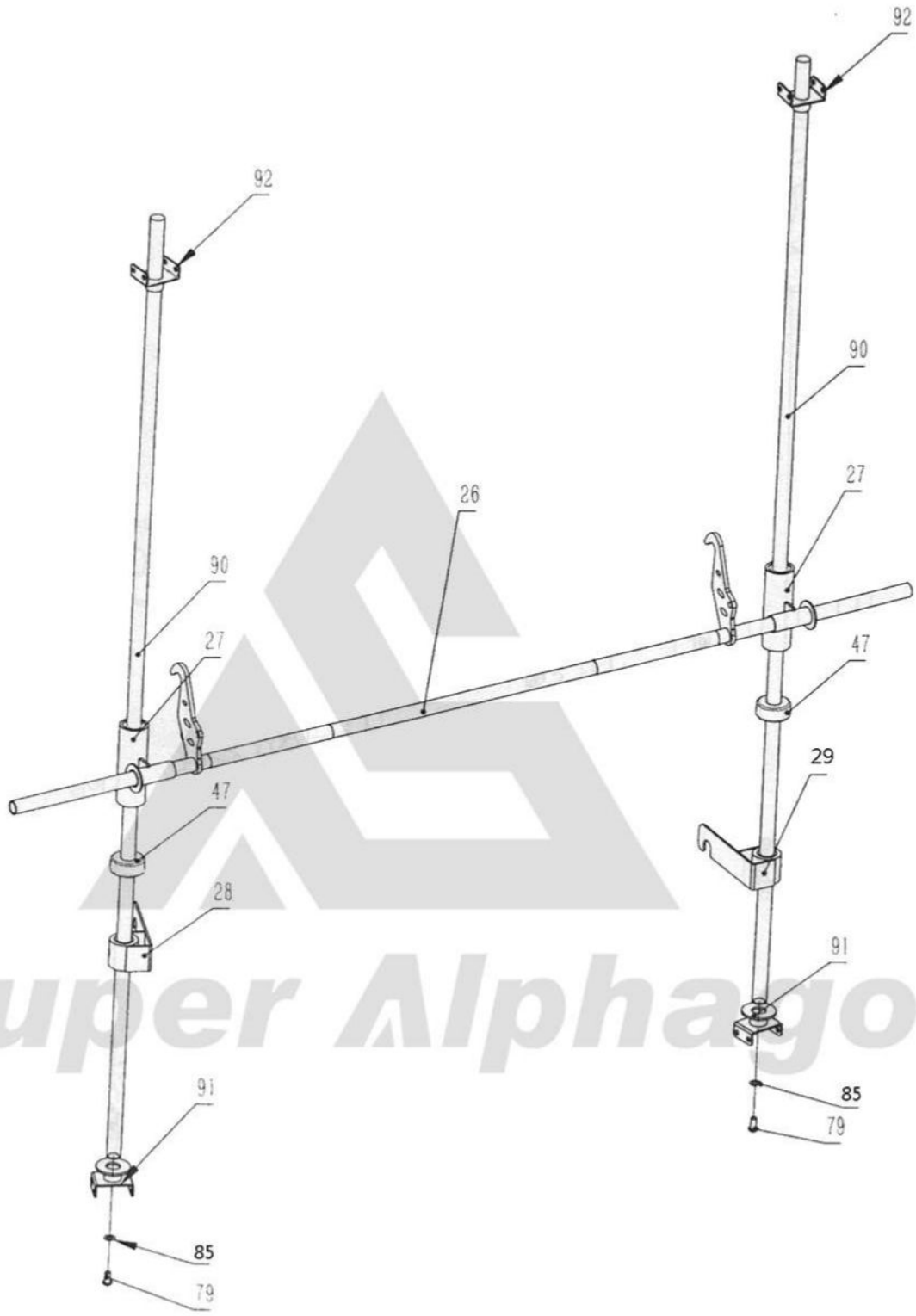

81

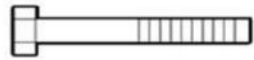

M8X80mm

8

86



Φ8

16

84



M8

8

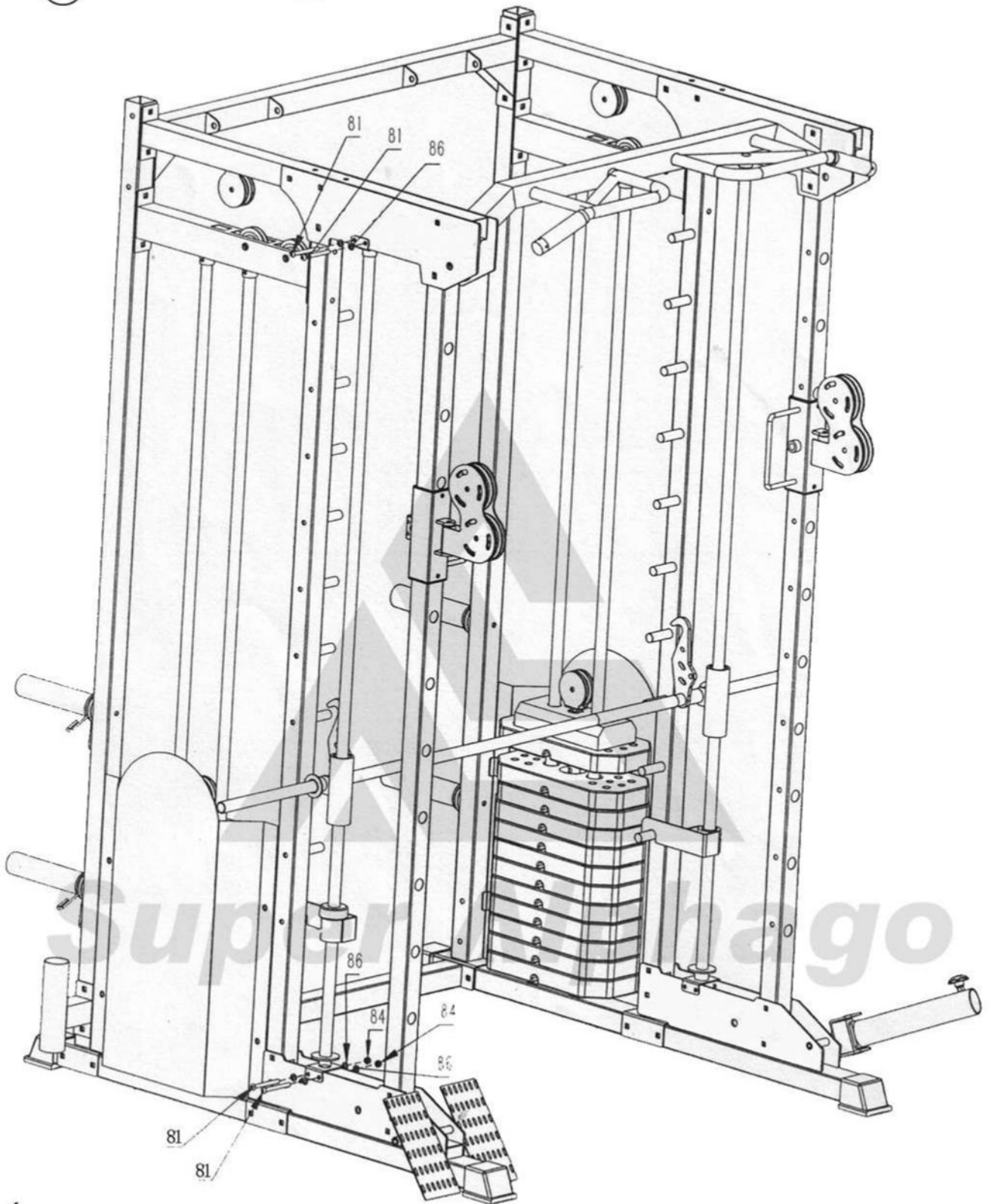

16

Maintenance

In order to prolong the service life of the instrument, the parts and components must be lubricated on time. This product has already carried on the preliminary lubrication to the instrument before leaving the factory. However, the necessary lubrication and maintenance between the guide rod and the weight plate must be carried out after a certain period of use.

Note:

1. Do not use edible oil or butter. It is recommended to use sewing oil. Therefore, pulley and wire rope should be regularly checked for signs of wear.
2. Check and adjust the tension of wire rope on a regular basis.
3. Regularly check all moving parts and make sure there are no signs of wear and damage. If there is any problem, user must stop immediately and contact our after-sales department.
4. During inspection, it is necessary to make sure that all bolts and nuts are completely fixed. If any bolts or nuts connection are loosened, please lock it in time.
5. Check for cracks in welds.
6. Failure to perform daily maintenance may result in personal injury or equipment damage.

Warranty

This machine has 3 years warranty for main frame and 1 year for parts.

No warranty is granted under any of the following circumstances:

1. Out of the warranty period.
2. Users modify the product structure by themselves.
3. Damage caused by human factors or natural disasters.



Super Alphago