

Hardware Sheet

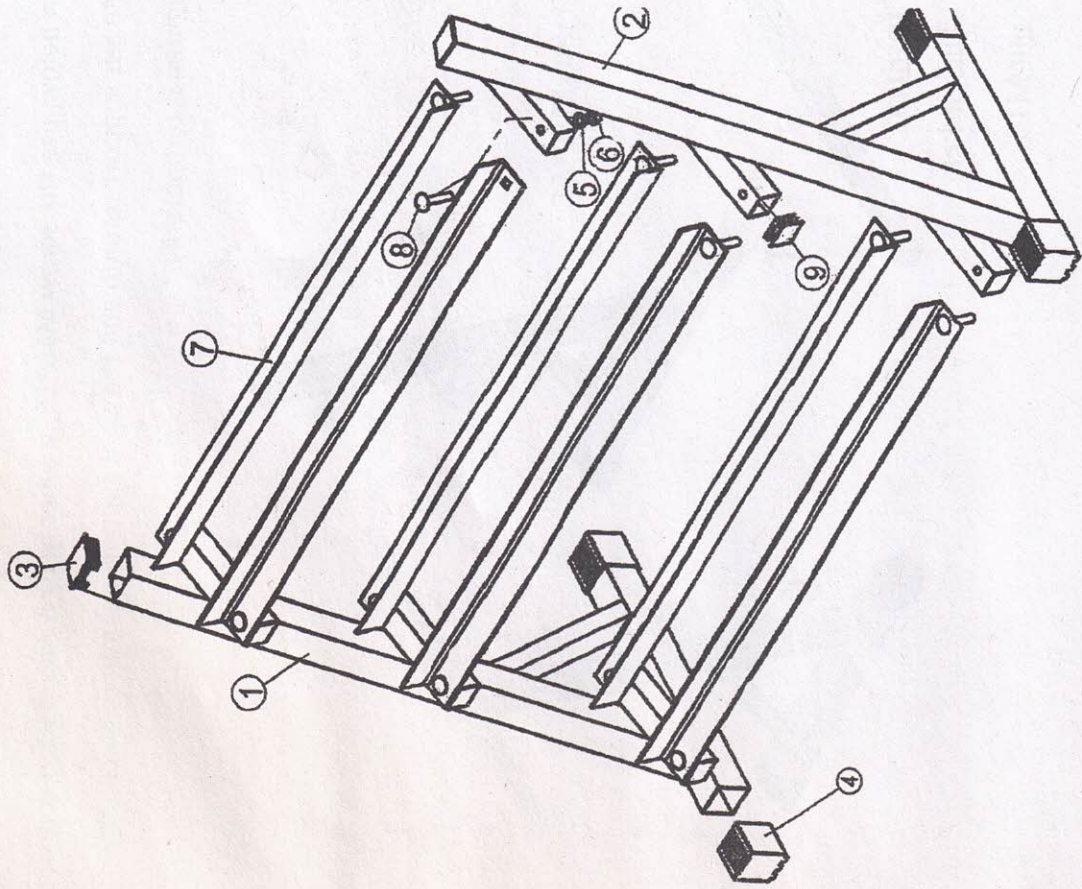

	Description	QTY
1	Left support	1
2	Right support	1
3	50X50 Tube stopper	2
4	50X70 Tube stopper	4
5	Φ10 Washer	12
6	M10 Nut	12
7	Dumbbell shell	6
8	M10*55 bolt	12
9	40X40 Tube stopper	12

Installation step 1:

Remove the dumbbell rack clapboard.

As shown below, use the screw M10*55, washer M10 & nut M10 to connect it with the left support column and the right support column respectively.

Do not tighten it temporarily.

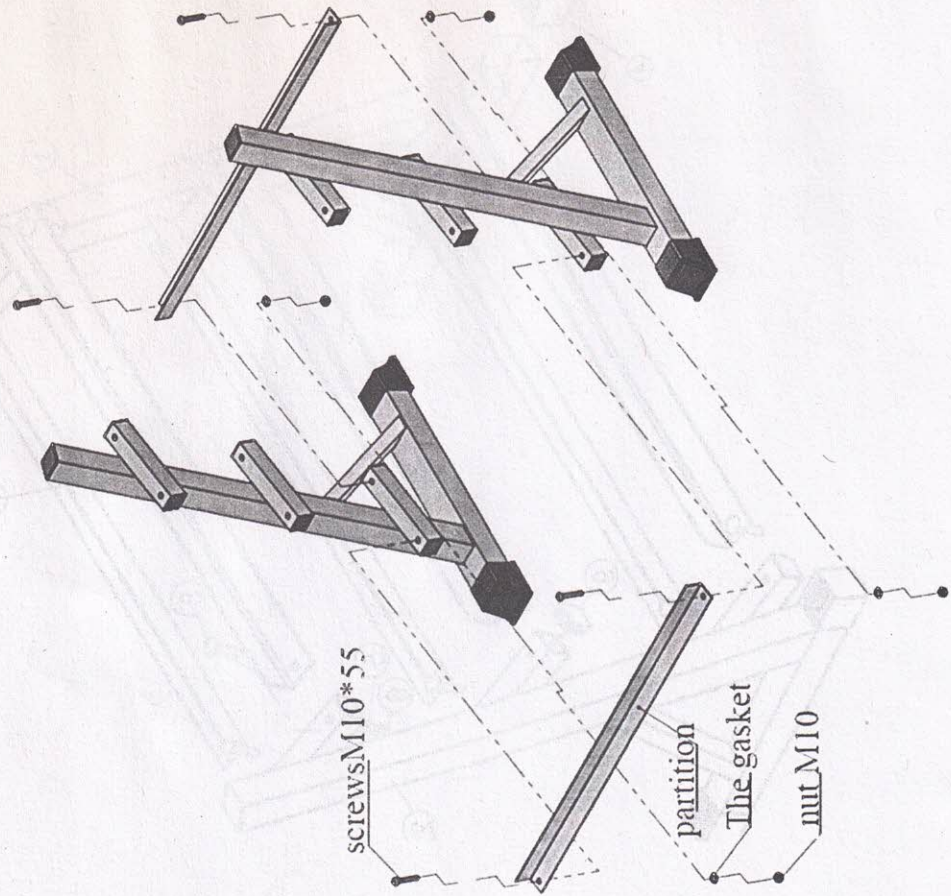

Installation step 2:

1. Repeat step 1 to install the other two layers of the "dumbbell shelves". Use the screw M10*55, washer M10 & nut M10 to separate them. Connect with "left support" and "right support"
2. Check that the three "dumbbell shelves" are in place before placing them. Screw fastening.
3. The effect of the installation of this facility is as follows.

