



eSafety Supplies

PRODUCT DATA SHEET

Unleashed Column Protector

PRODUCT INFORMATION

PRODUCT COLUMN PROTECTOR

CODE UCP

DIMENSIONS Outer size: 620 x 620 x 690mm
Inner size: 350 x 350 x 630mm

WARRANTY 12 Months

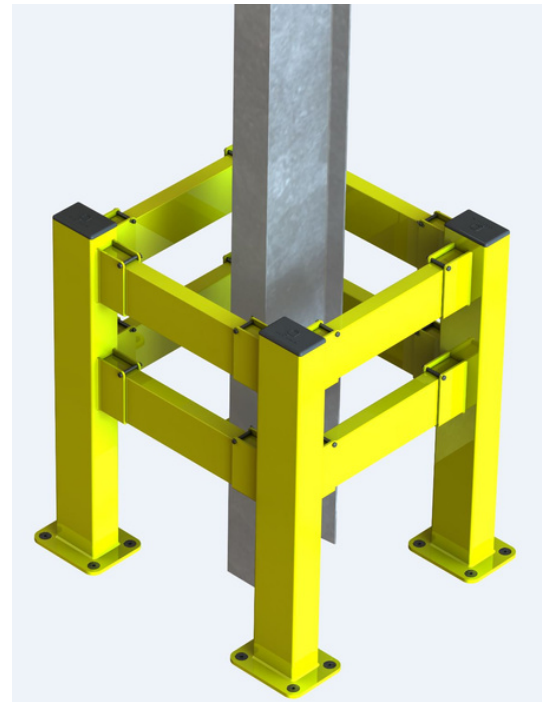

YELLOW

HOW TO SPECIFY

DESCRIPTION

The Unleashed Column Protectors safeguard your building's support columns and down-pipes from vehicle impact, preventing structural damage to your building as well as the risk of workplace injury. Structural columns are common in warehouse facilities and often situated near vehicle traffic.

MANUFACTURER

eSafety Supplies
P: 1300 291 700
E: SALES@ESAFETYSUPPLIES.COM.AU
W: WWW.ESAFETYSUPPLIES.COM.AU

