

Measure 16" from
front of neck
to backbone
and mark for cut

1982-1991 Models

Measure hardtail from motor mount to the end of the frame (not the end of the slug).

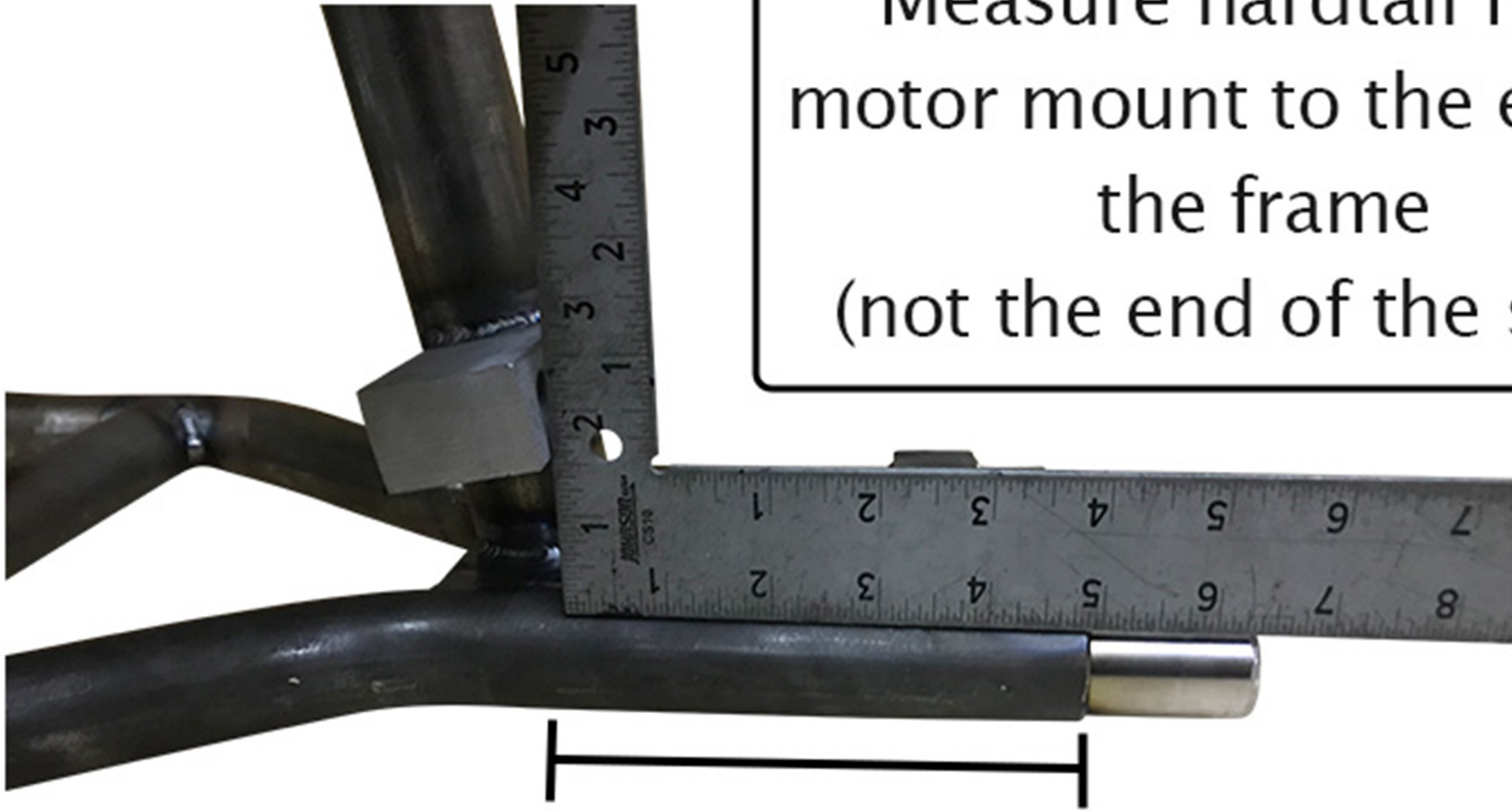

Transfer that measurement to the stock frame and make your cut in that location.

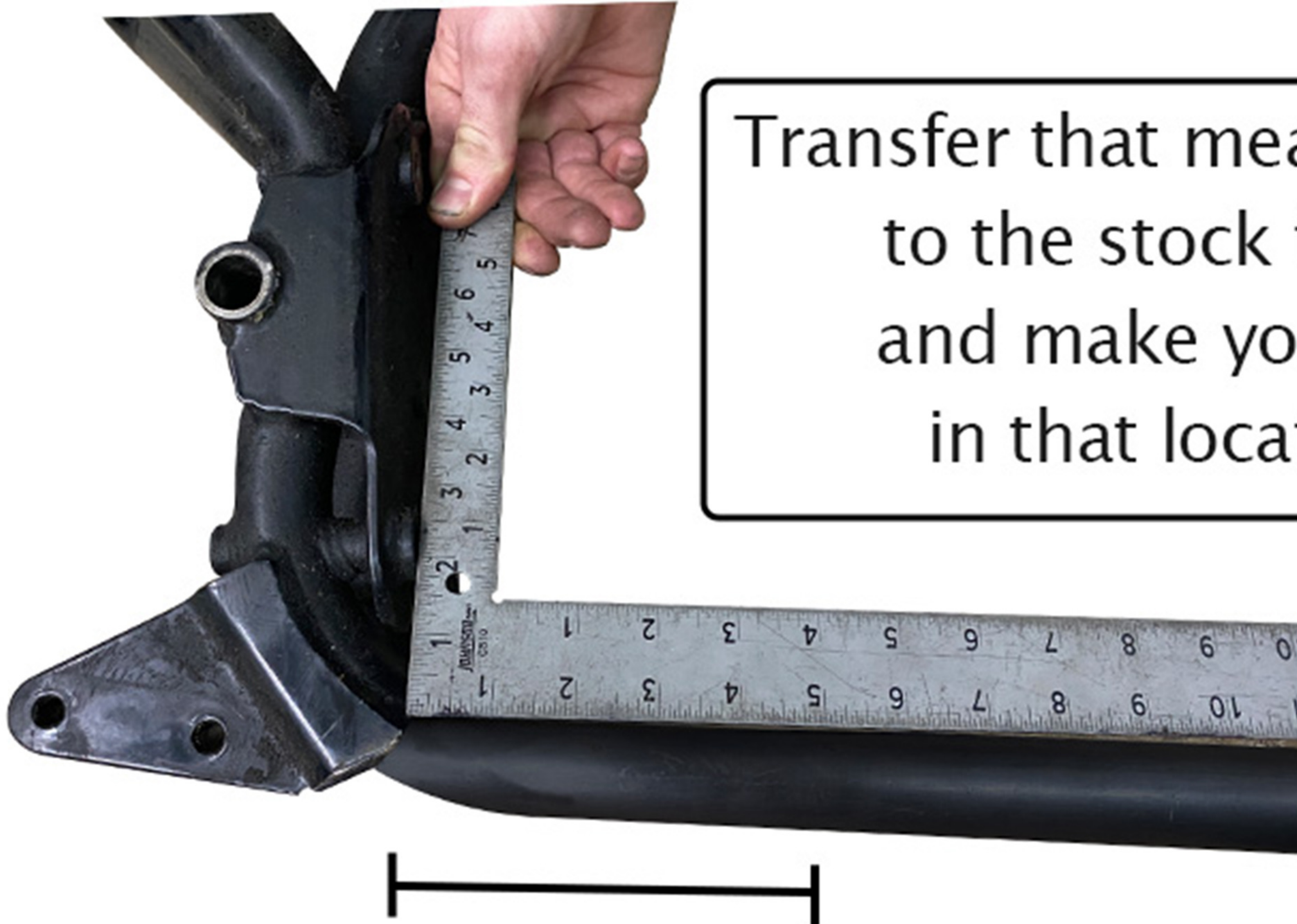

1992-2003 Models

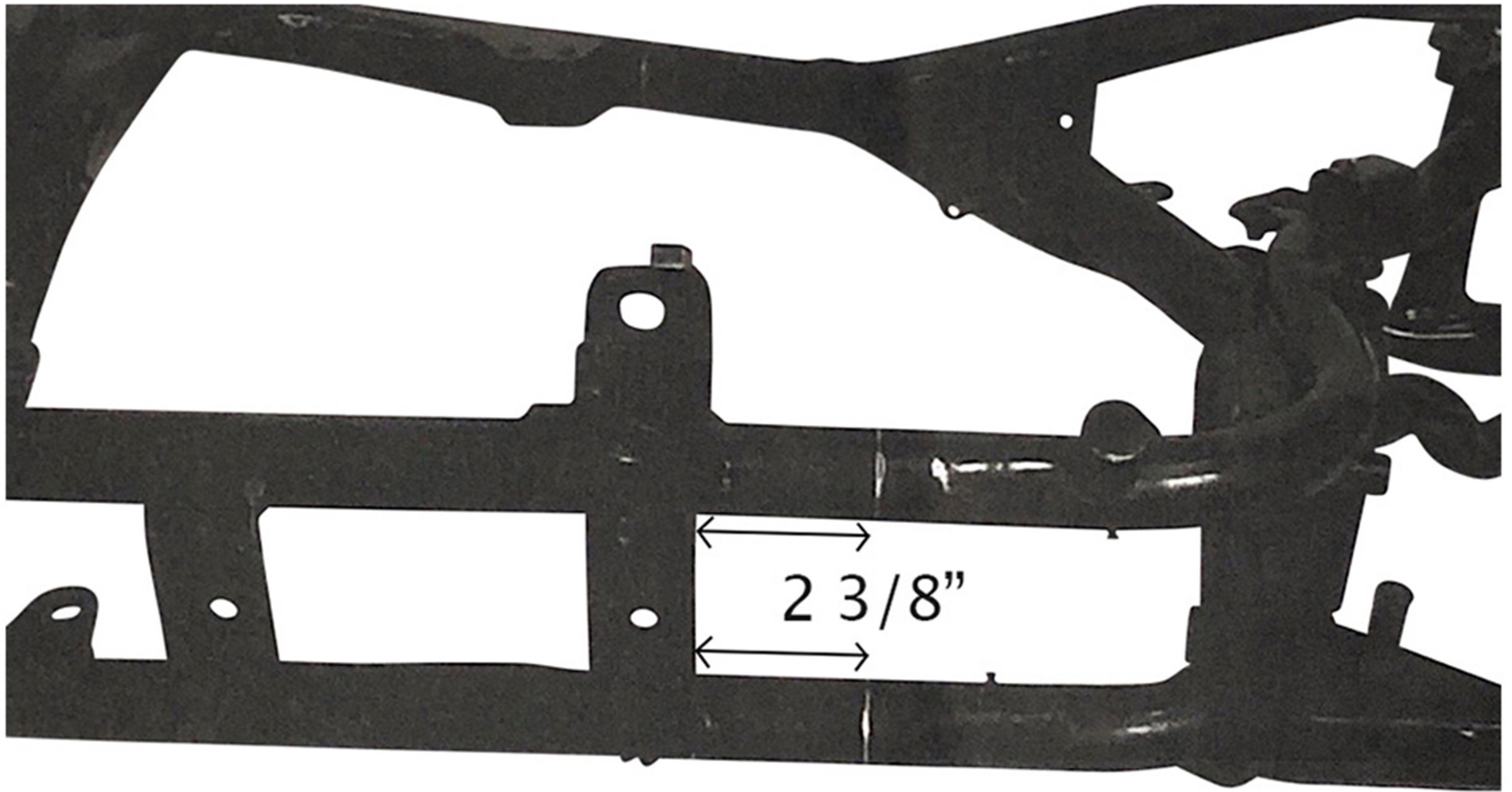

Measure 2 3/8'' back from the back edge of the rear cross bracket and make cut marks

Cut behind your mark and sand to ensure a flat mating surface

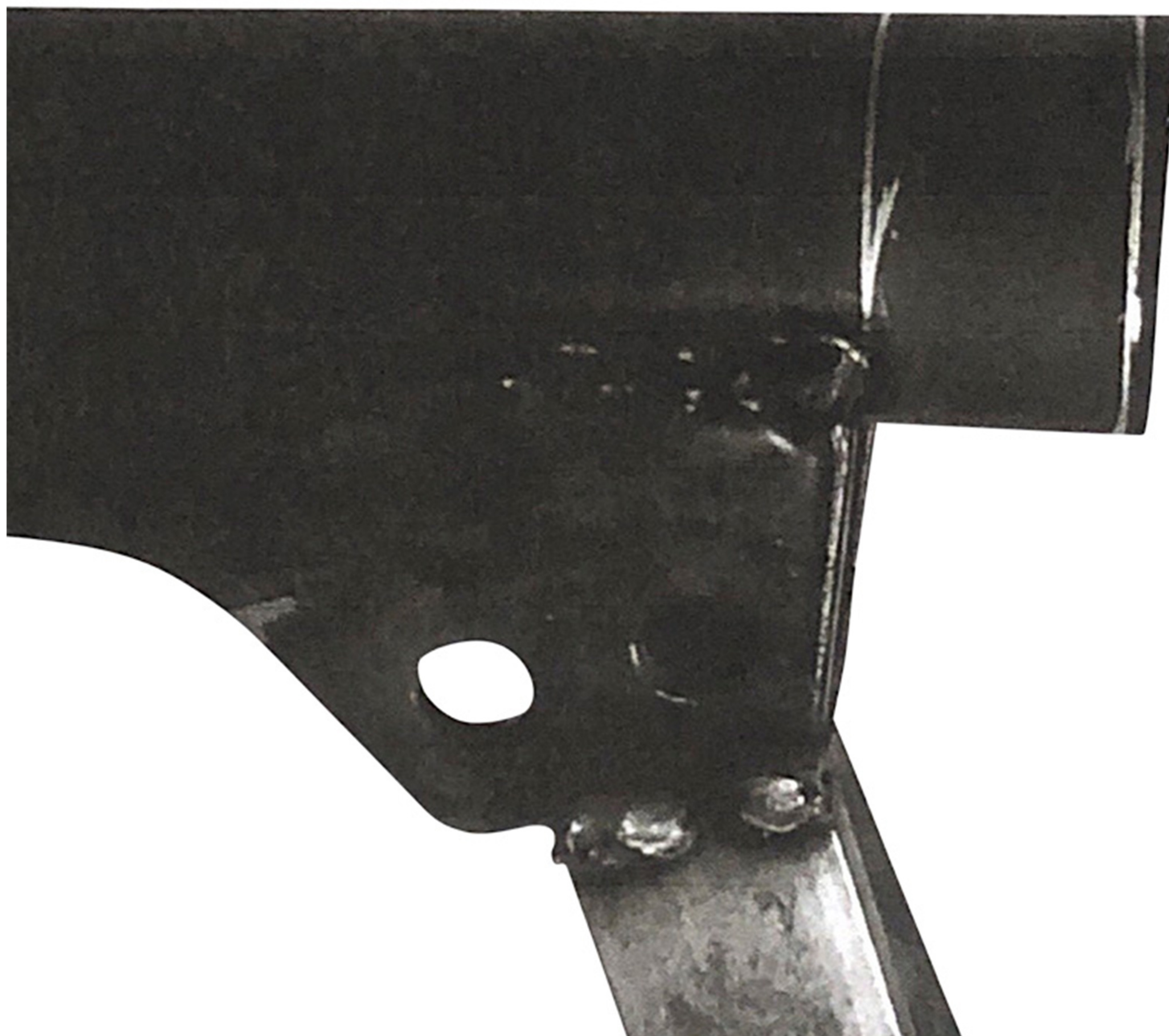
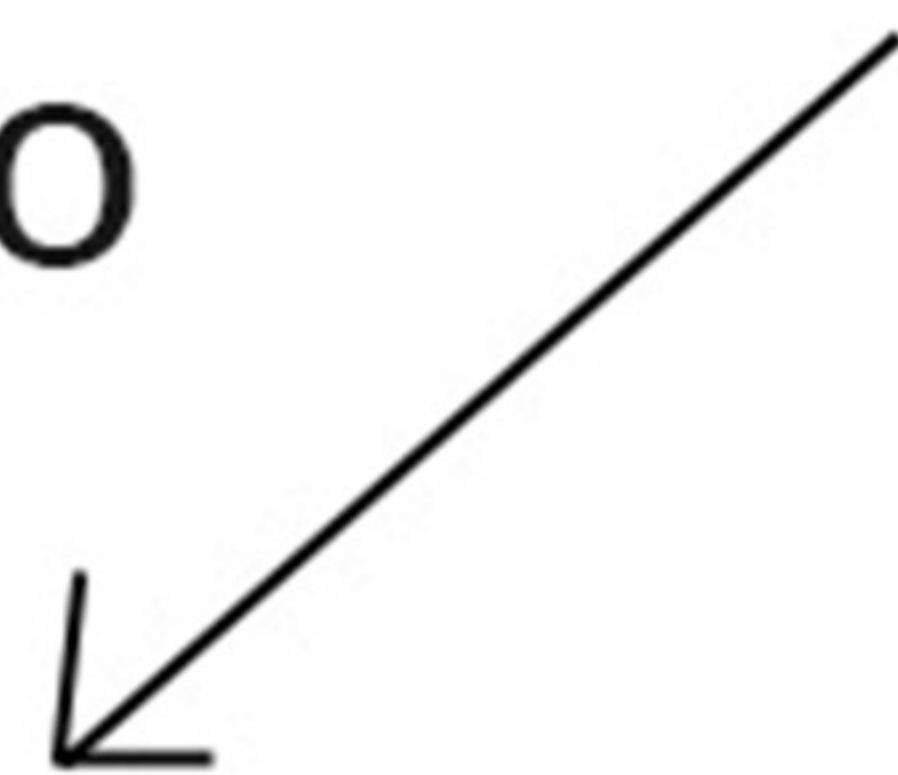

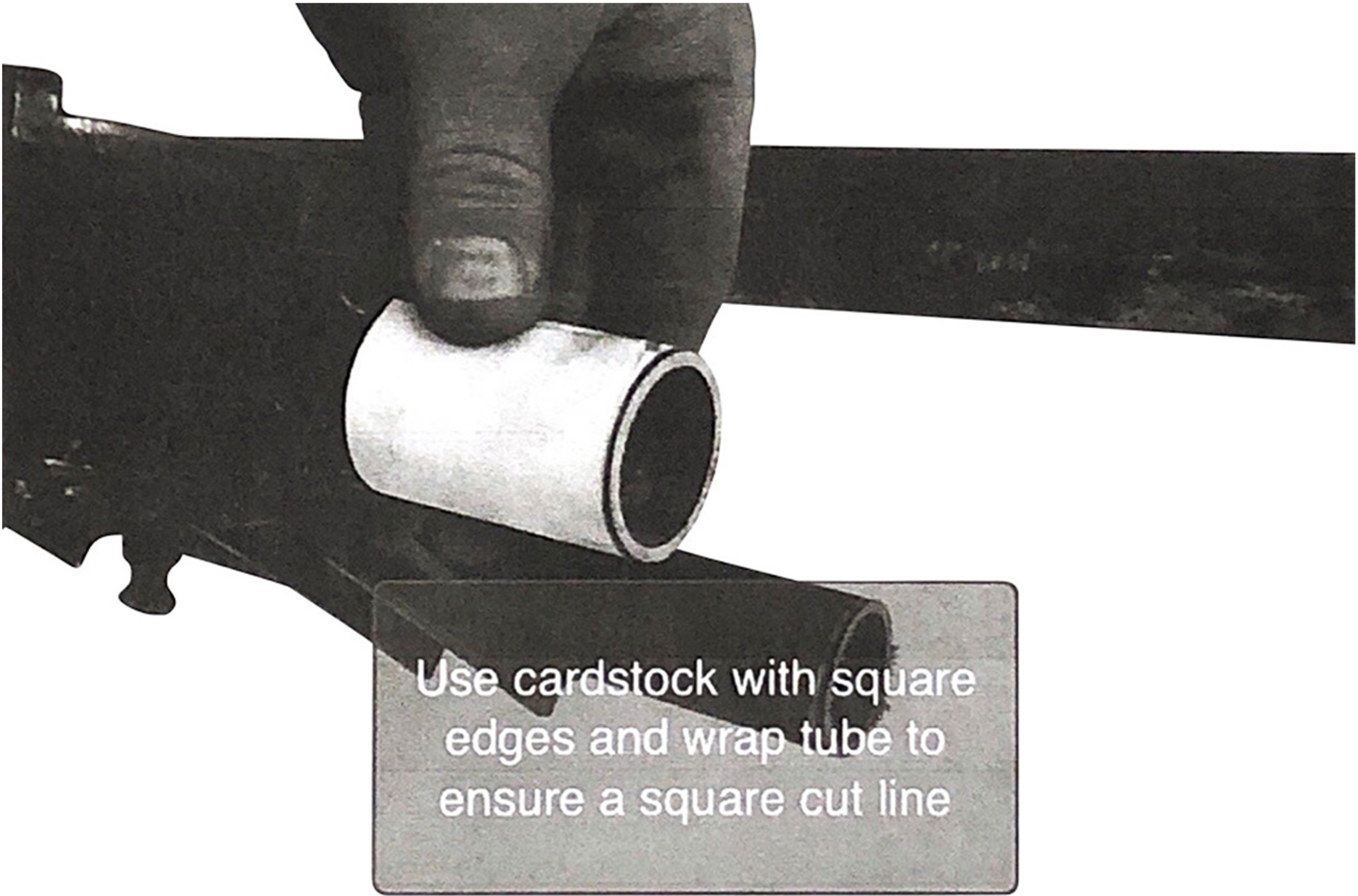

Use cardstock with square edges and wrap tube to ensure a square cut line

Drill $2\frac{1}{64}$ " holes for plug welds
 $\frac{1}{2}$ " in from end of tube

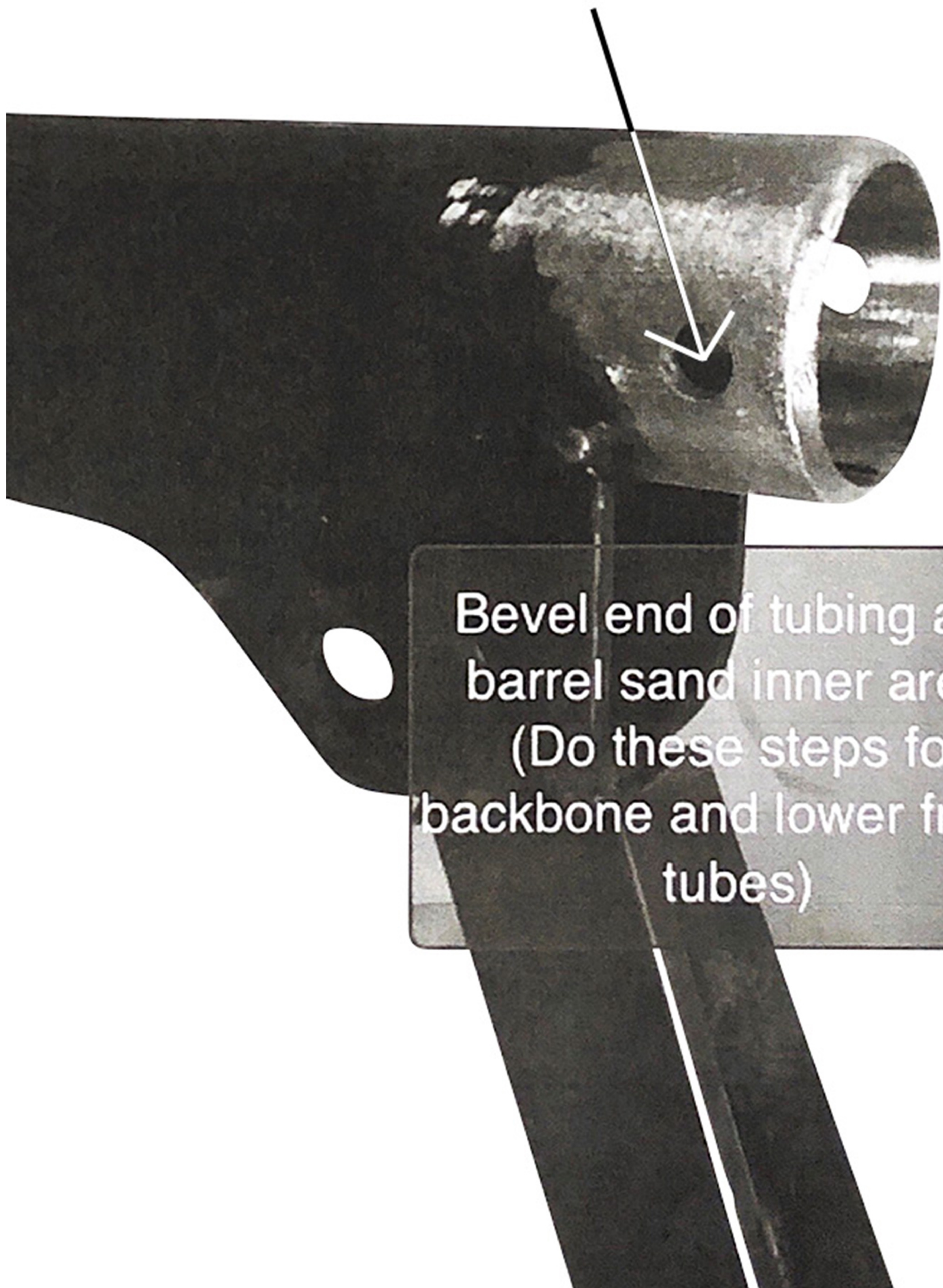

Bevel end of tubing and
barrel sand inner area.
(Do these steps for
backbone and lower frame
tubes)

Keep small gap to be sure weld penetrates the frame slug and both sides of tube.

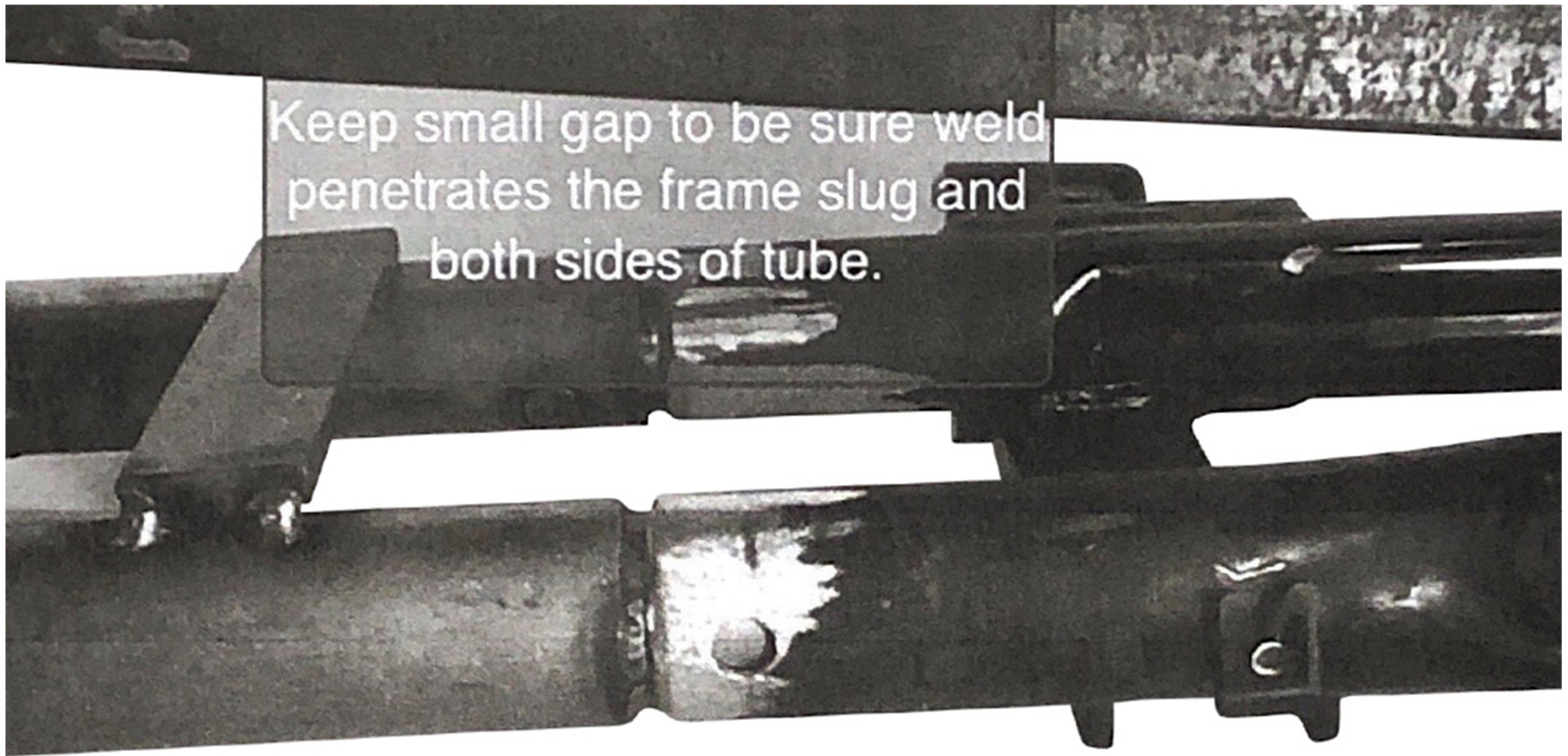

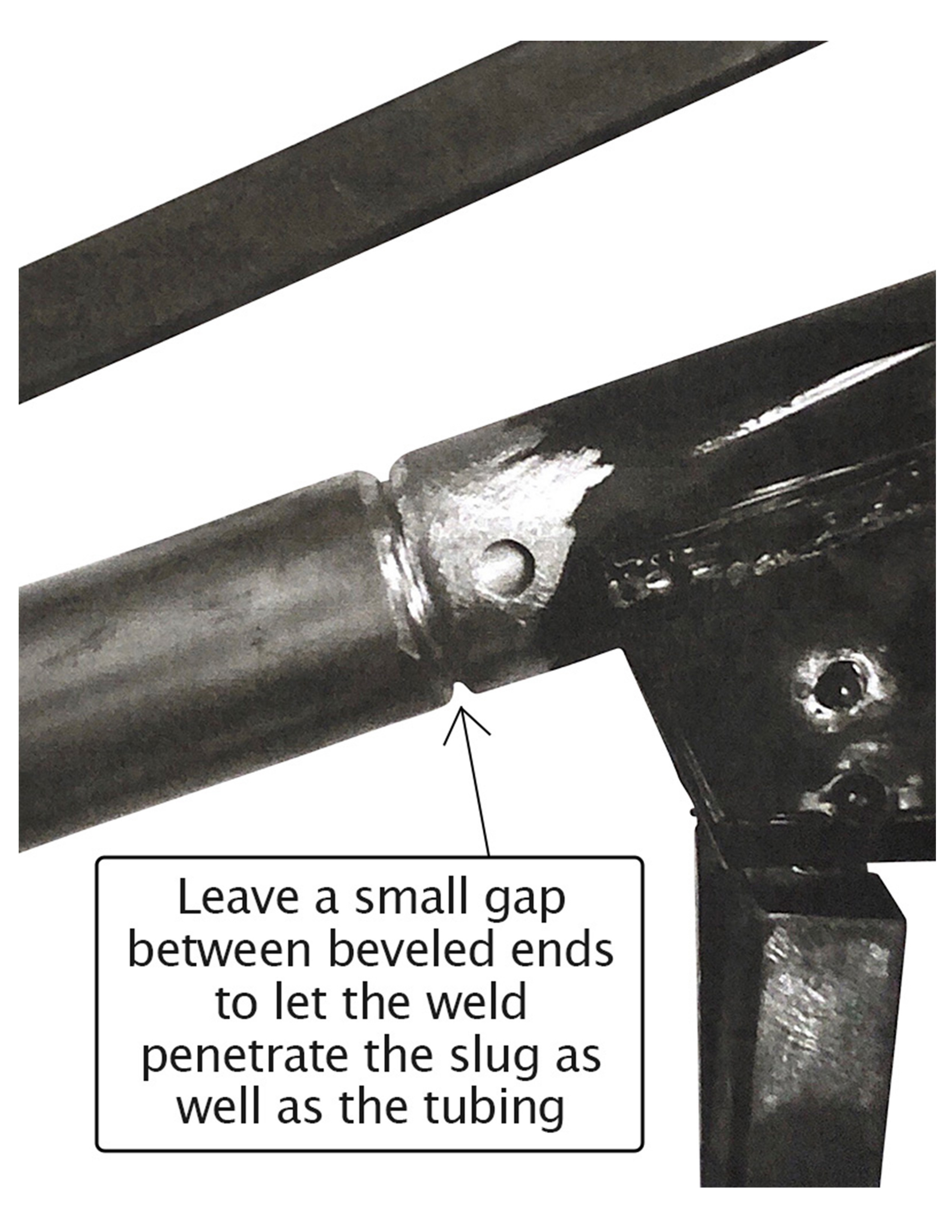

Leave a small gap
between beveled ends
to let the weld
penetrate the slug as
well as the tubing

Use a clamp to bring frame sections together. Build a temporary jig as shown, or install engine to be sure placement is correct before welding.

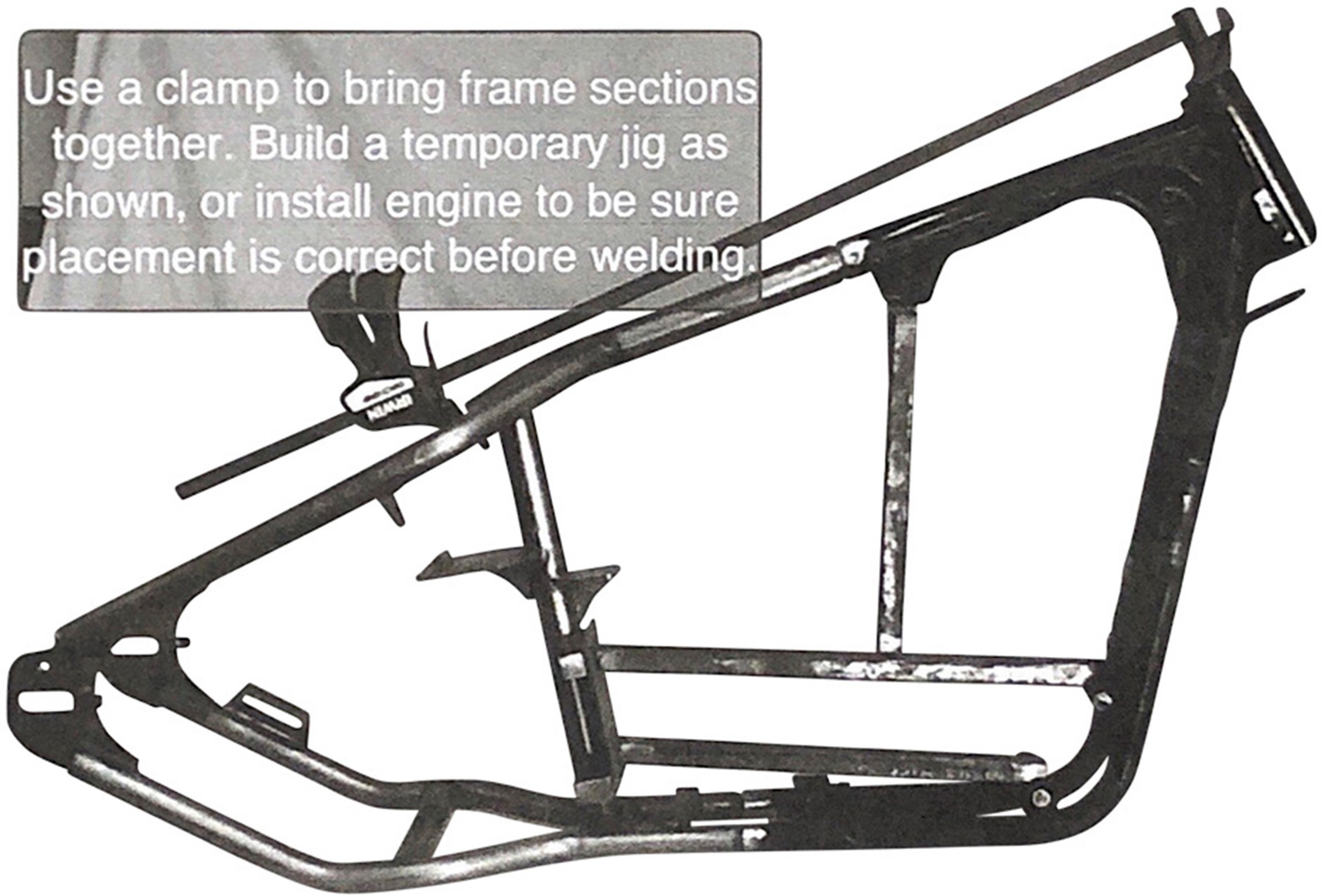

HARDWARE LIST FOR THE SPORTSTER HARDTAIL KIT

KING & QUEEN SEAT MOUNT
(1) 1/4"-18 X 1"
[INCLUDED]

LEATHER WASHERS

SKU: 2030 - 1" WITH 5/16" CENTER

SKU: 2031 - 1" WITH 3/8" CENTER



FENDER TO SISSY BAR

(2) 5/16"-18 X 3/4"

OIL TANK MOUNTS

(4) 5/16" 18X 1"

(2) 5/16" 18X NUT

SISSY BAR MOUNTS

(2) 3/8"-16 X 1.25"

MOTOR MOUNT

(4) 3/8"-24 X 2.5"

(2) 3/8"-24 NUT

BRAKE STAY

(2) 3/8"-6 X .75"

[INCLUDED]

FENDER MOUNTS

(2) 3/8"-16 X 1.5"

(2) 3/8"-16 NUT

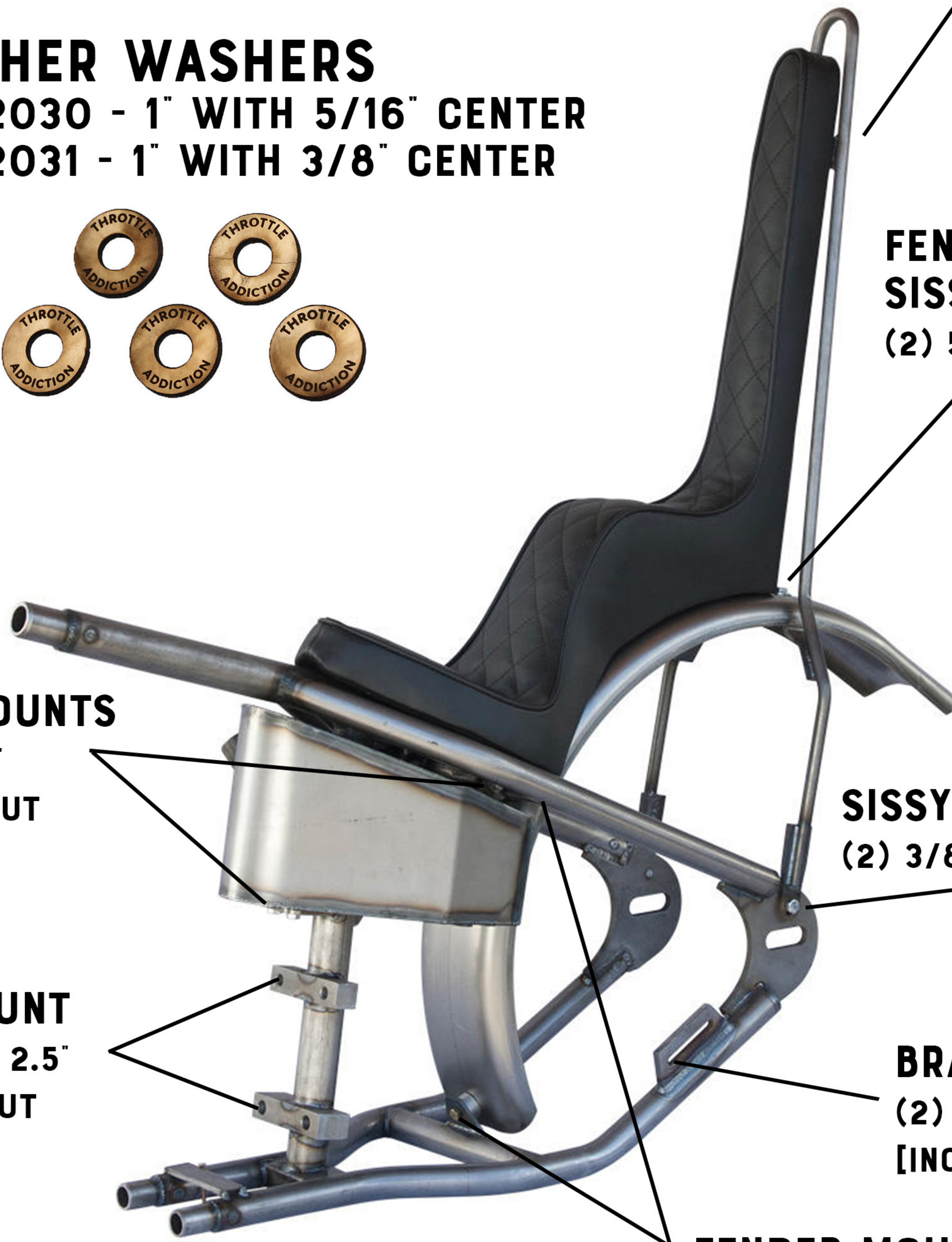

HOW TO MOUNT OEM BRAKE CALIPERS ON THE HARDTAIL KIT

1982-1999
SKU: 8180



1982-1986

BEFORE AFTER

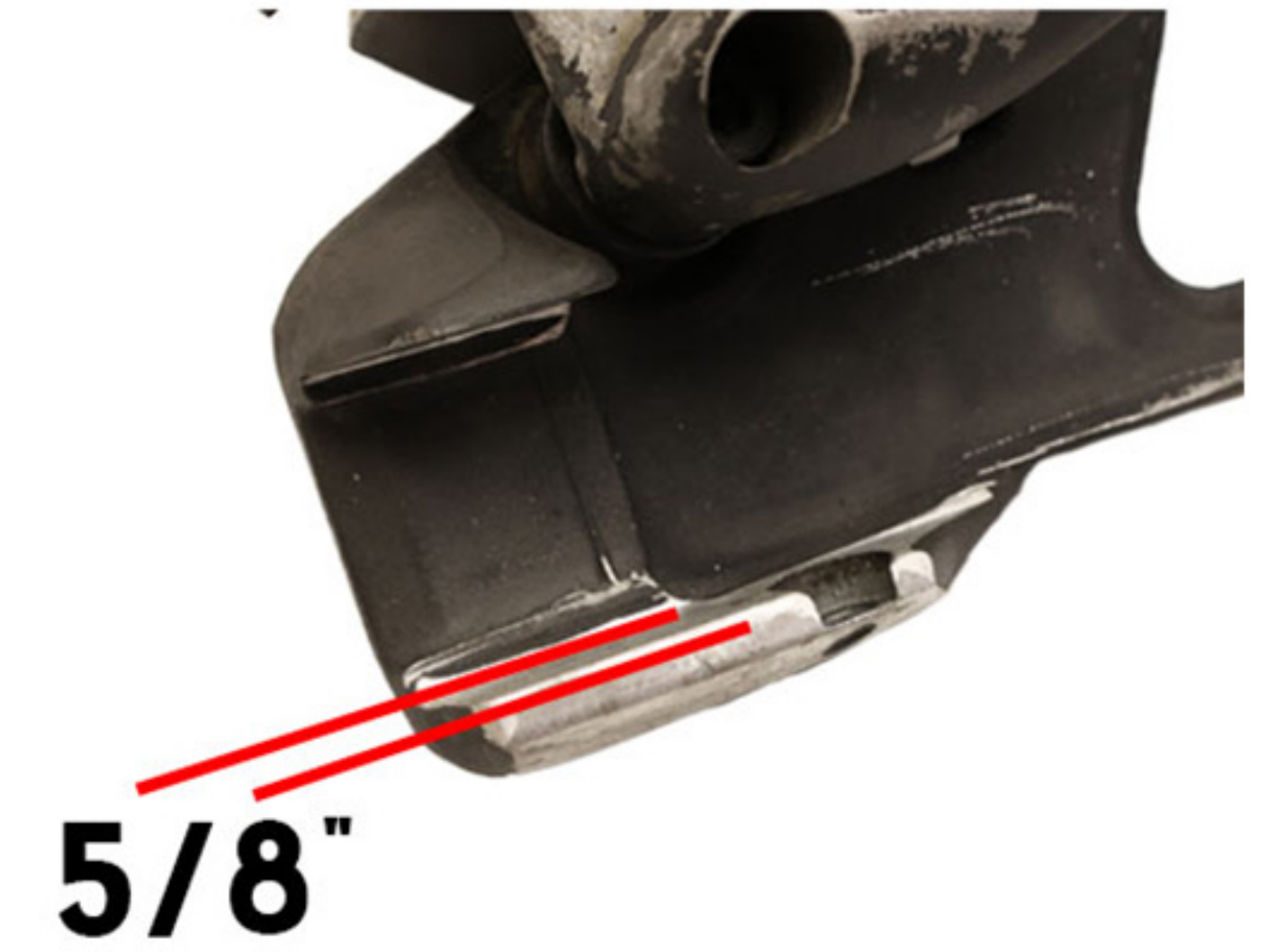

1. REMOVE RUBBER BUMPER
2. USE A FILE TO OPEN UP THE CHANNEL UNTIL THE BRAKE STAY BLOCK SLIDES IN
3. GRIND LOWER WEB TO 5/8" DEPTH
'IT MAY BE NECESSARY TO GRIND BOTTOM OF BRACKET TO REDUCE CONTACT WITH FRAME

1987-1999

BEFORE AFTER

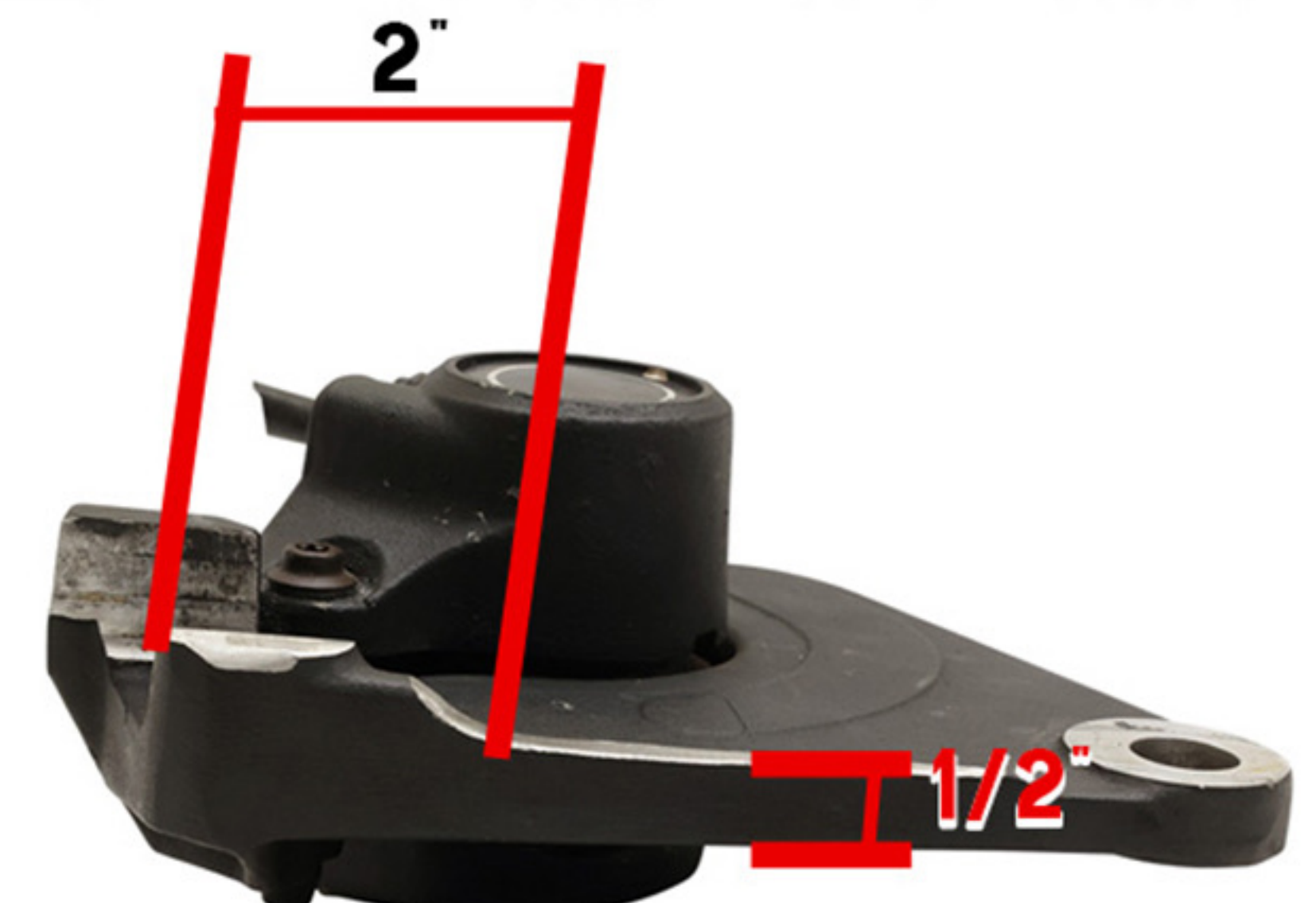

1. REMOVE RUBBER BUMPER AND GRIND OFF TAB
2. MEASURE 2" BACK FROM END OF LOWER WEB
3. GRIND LOWER WEB TO 1/2" THICK FROM MARK BACK
'IT MAY BE NECESSARY TO GRIND BOTTOM OF BRACKET TO REDUCE CONTACT WITH FRAME

2000-2003
SKU:8151



**NO CALIPER
MODIFICATION
REQUIRED**