

Introduction to Your New Sherman Air Frame

Thank you for purchasing the Sherman Air Frame. We hope that it will provide a useful training area for years to come.

A few things to consider before beginning assembly. First, open all boxes and make sure you have all of the parts. Next, read through the instructions for the frame and the winch and make sure you understand them. You may want to start by assembling the frame, and use that to guide where you install the Bracket Hanger Assemblies. We wanted to keep the floor clean should you be using lifts. Now, make sure you have all of the tools you will need to install the frame. You will need 1/2", 9/16" and 3/4" wrenches and a ladder that can reach your ceiling to assemble the frame. Read through the winch instructions and make sure you have the ability to securely mount the winch to the wall. Do not hesitate to ask a local handyman to help with any part of the process.

This frame is designed to provide years of use, but some care is required. Care should be taken to minimize extra weight being added to the cage. The extra weight will cause undue wear and possible deformation of the frame and its parts. Caution should also be used when operating the winch. Make sure the area below and above the frame is free from obstruction before raising or lowering the frame. Also do not abuse the winch remote. Rapid back and forth movement will cause damage to the winch and the frame.

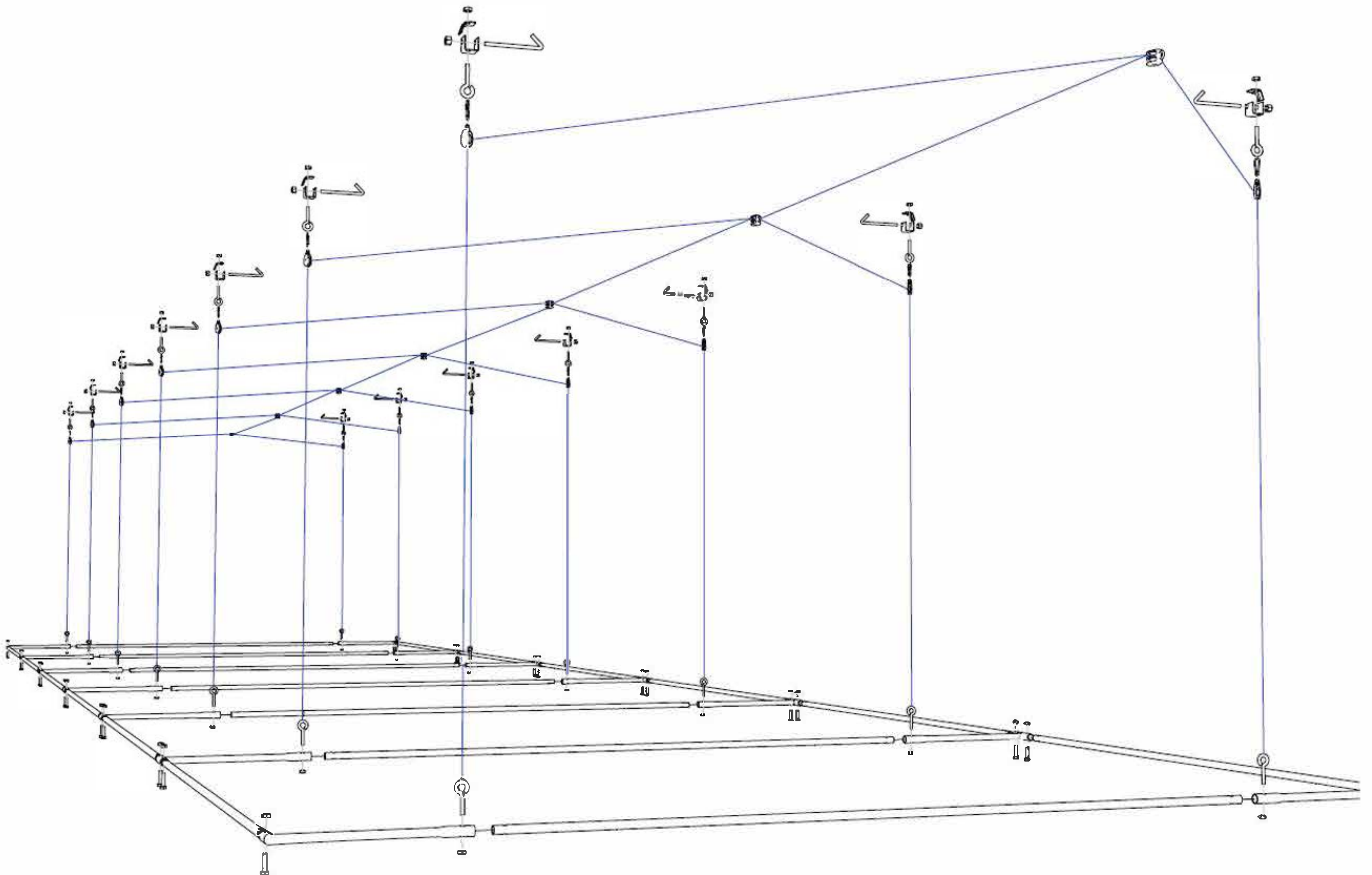

Part		QTY	Part		QTY
A	Beam Hanger Clamps	15	I	2"L 5/16" Bolts and Nuts	24
B	5"L 5/16" Eye-Bolts and Nuts	15	J	1/4" Runner Cables	6
C	2-way 1-1/2" Corners	4	K	1/4" Support Cables	7
D	3-way 1-1/2" Corners	10	L	Motorized Winch Assembly	1
E	Single Pulleys	16	M	1/4" U-Bolts	54
F	Eye to Eye Pulleys	6	N	Carabiner Hooks	15
G	10'L Steel Pipe	17	O	5'L Steel Pipe	2
H	3"L 5/16" Eye-bolts and Nuts	14	P	1/4" Runner Cables (Small)	1

1. Establish where you would like your frame and the location to mount your winch. Measure the distance of how far apart the ceiling joists are. We recommend mounting the Winch on the wall directly in the middle of the frame's end arch. The maximum distance of the center pulley above the winch from the first cross cable is the maximum distance that the frame will raise.
2. Assemble each Beam Hanger Clamp (A) using the 5" eyebolts (B) so that it will loosely fit over the bottom of the ceiling joist. Attach one Single Pulley (E) to the eye of the Eye-Bolt (B) with a Carabiner (N). This creates the Beam Hanger Assembly [DIAGRAM 1].
3. Starting closest to the location where you want the Winch, attach the beam hangers so that they are 10' apart, going the length of the frame and then 5' for the final gap.
4. Now at 10' distance (width), attach the 7 other Beam Hanger Assemblies.
5. Attach the last Beam Hanger Assembly, for pulling the cables upward, between the winch and the frame. Keep in mind that the distance between this pulley and the middle of the column of the nearest Beam Hanger Assemblies is the maximum distance the frame will travel.
6. Lay out the frame as per DIAGRAM 3 beneath your Beam Hanger Assemblies. Pipes are labeled as to the corner they connect to. All writing goes face up.
7. Starting at one side attach the 10' pipes (G) to the 2-way corners (C), drill a hole at the connecting points and secure with Bolts (I) and Eye-bolts (H). [DIAGRAM 4].
8. Move on to assembling the Pipes (G) to the 3-way corners (D), drill and secure with Bolts (I) and Eye-bolts (H). [DIAGRAM 5]
9. Finish with the final pair of 2-way Corners (C) and the 5' Pipes (O) drill and secure. [DIAGRAM 4]
10. Put your cage over the frame. Make sure it is centered and use the eyebolts to hold it in place.
11. Starting on one side of the frame, loop one Length of the Support Cable (K) through the Eyebolt (H) and clamp it down using 2 ea. 1/4" U-Bolts (M). [DIAGRAM 6]
12. Run the Cable through the Single Pulley (E) above it, through the top pulley of the Eye to Eye Pulley (F) to the Single Pulley (E), on the other side of the frame, and back down to the Eyebolt (H) on the other side of the frame. [DIAGRAM 7]
13. Repeat steps 12 and 13 all the way down the frame.
14. For the Assembly furthest from the Winch, use a Single Pulley (E) instead of the Eye to Eye Pulley (F).
15. Attach the middle Single Pulley (E) from step 14 to the Eye to Eye Pulley (F) in front of it, by looping the Small Support Cable (P) through the eye of the Single Pulley (E) and securing the loop with 2 U-Bolts (M).
16. Loop the other end of the Small Runner Cable (P) through the eye bottom of the Eye to Eye Pulley (F) and secure that with 2 U-Bolts (M). [DIAGRAM 8]
17. Repeat step 15 to secure the rest of the Eye to Eye Pulleys (F) to one another, using the Runner Cables (J) [DIAGRAM 8]
18. Mount the Winch (L) following the instruction in the box.
19. Loop the winch cable around the eye of the front Eye to Eye Pulley and secure with 2 U-Bolts (M).
20. Adjust the Runner Cables (J) so that they are taut whereby the frame will pull up evenly.

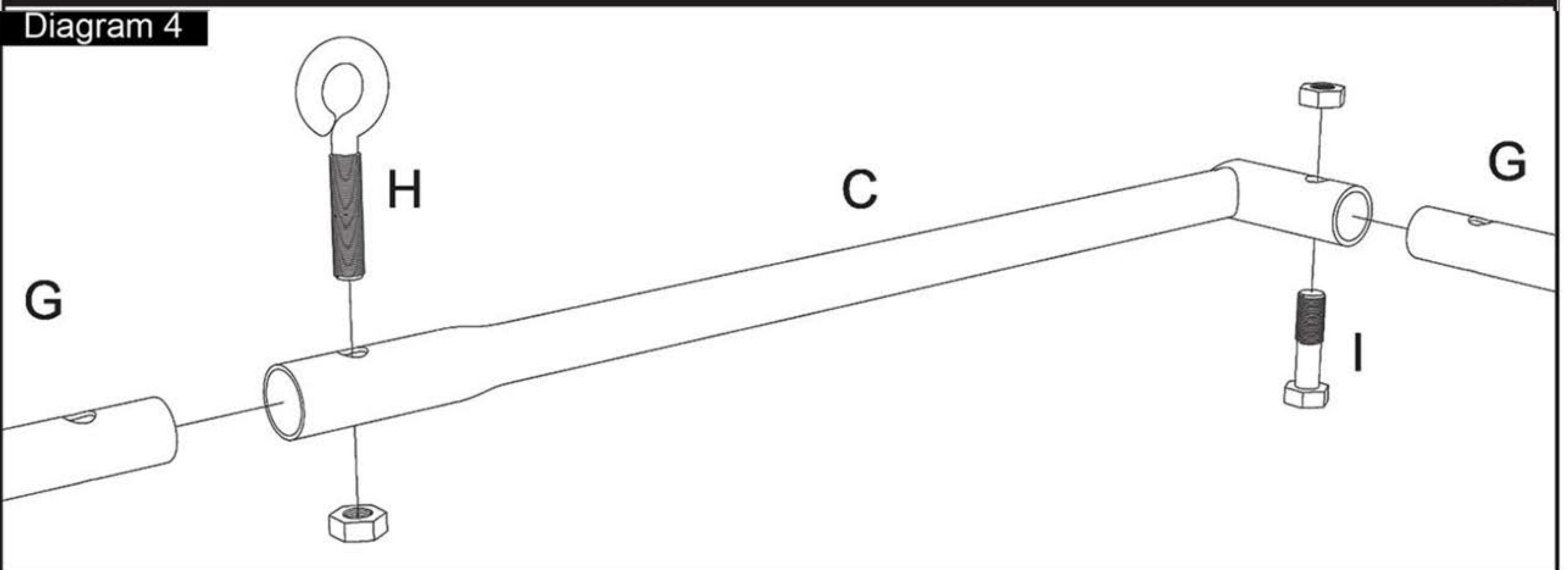
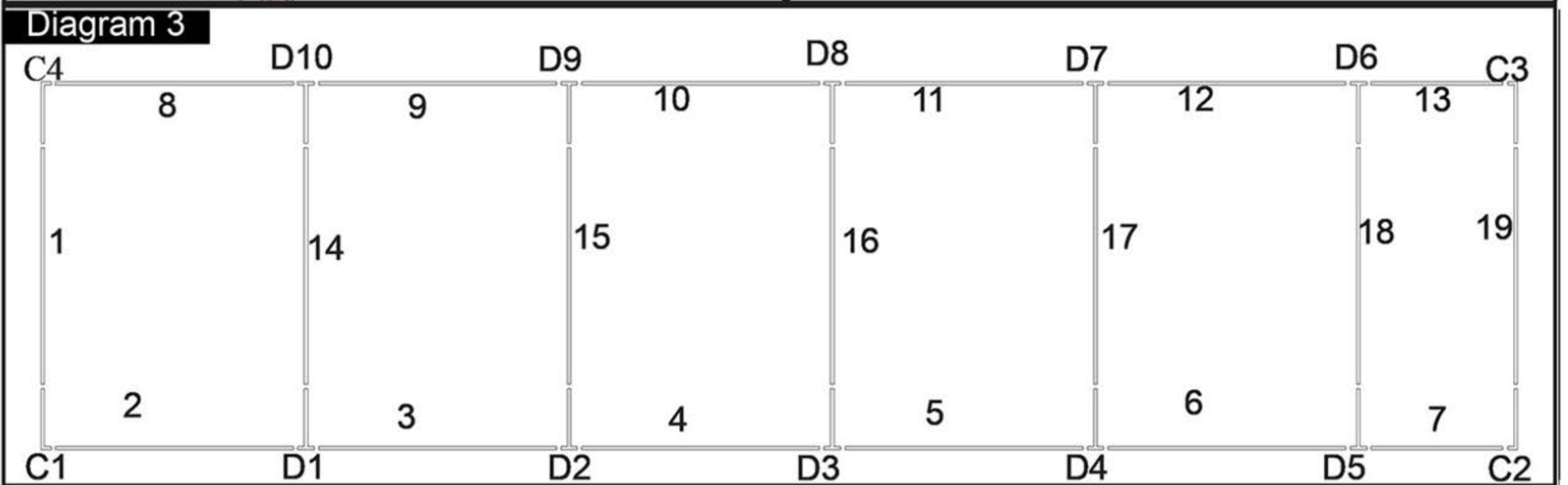
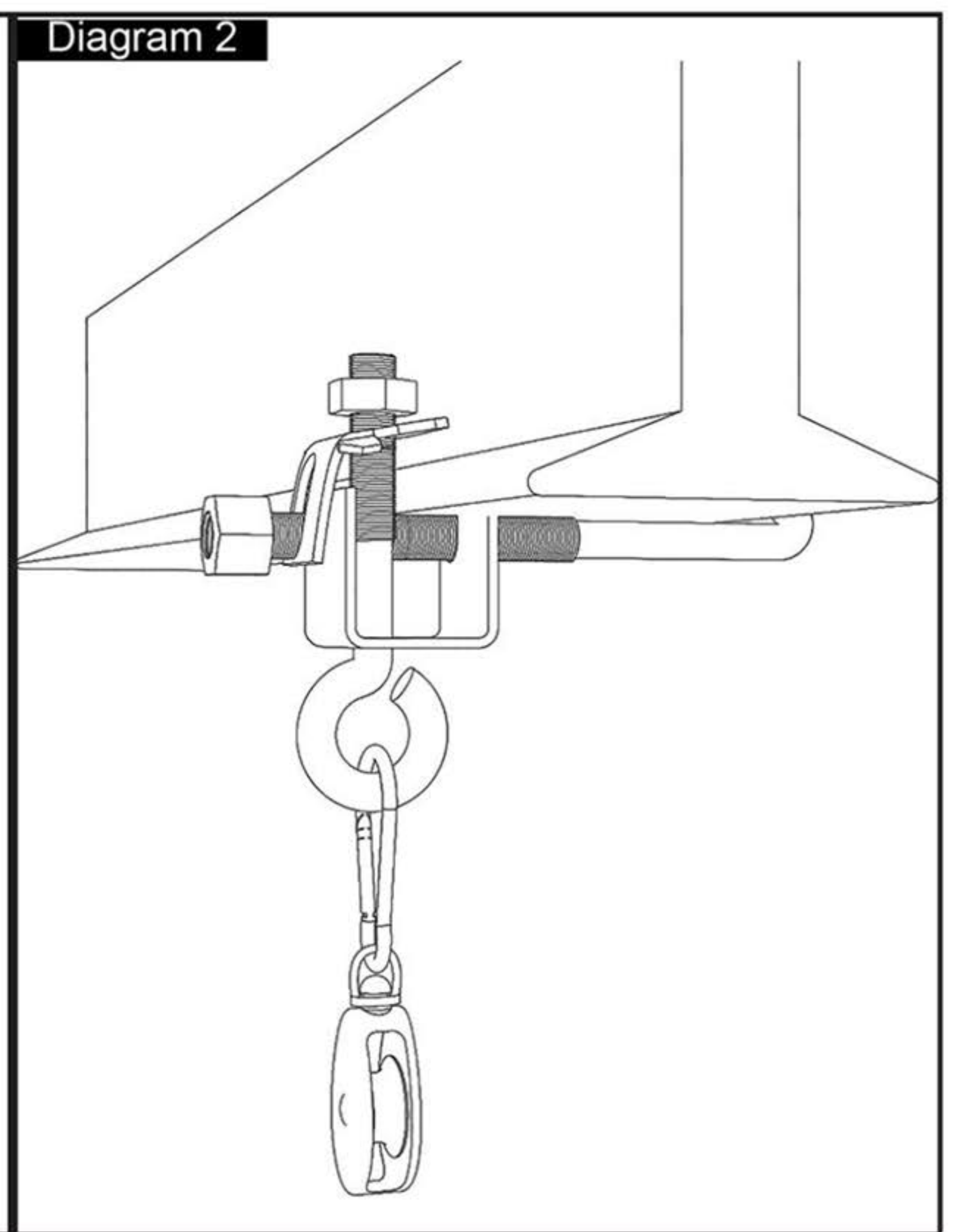
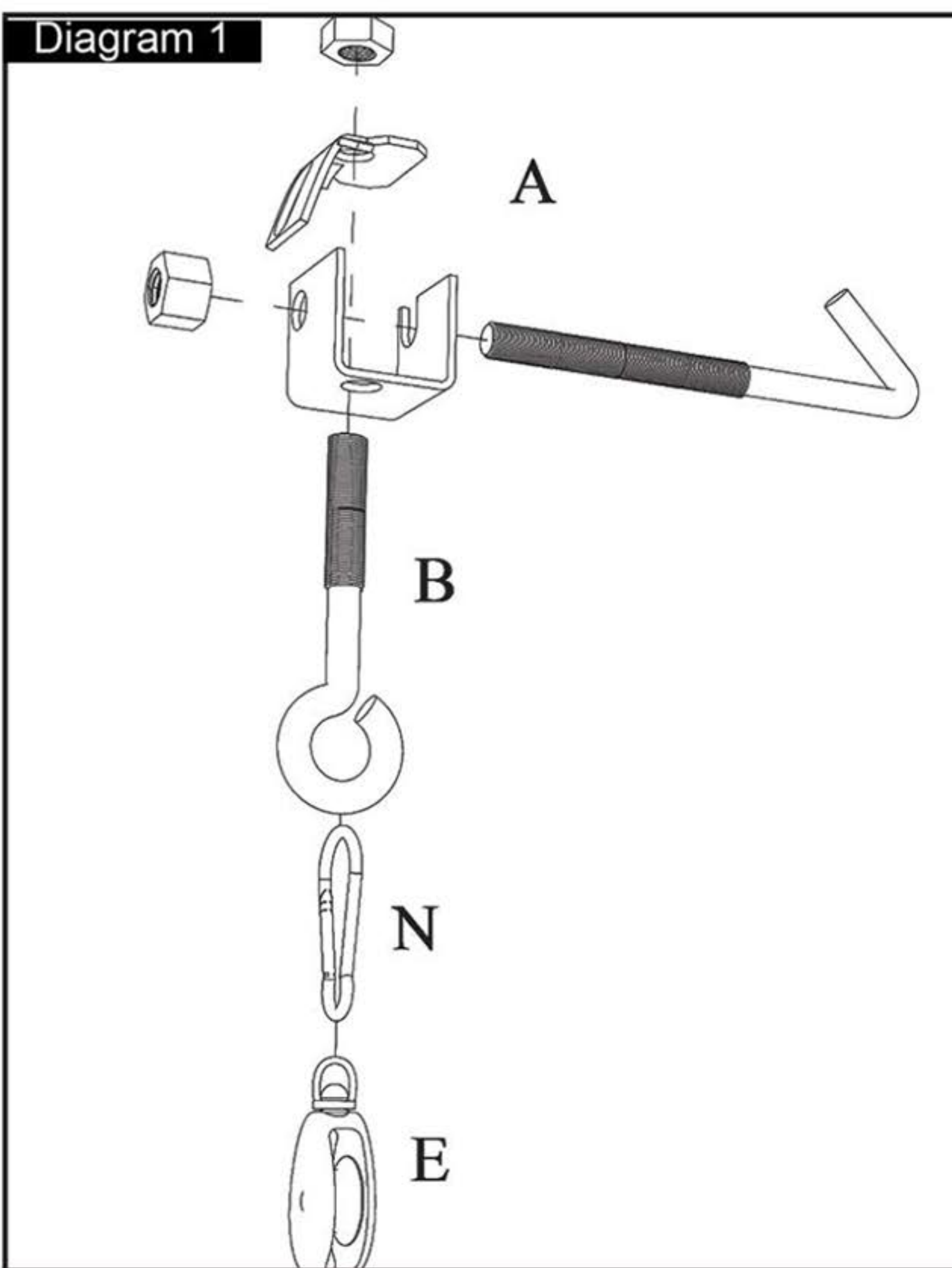

Diagram 5

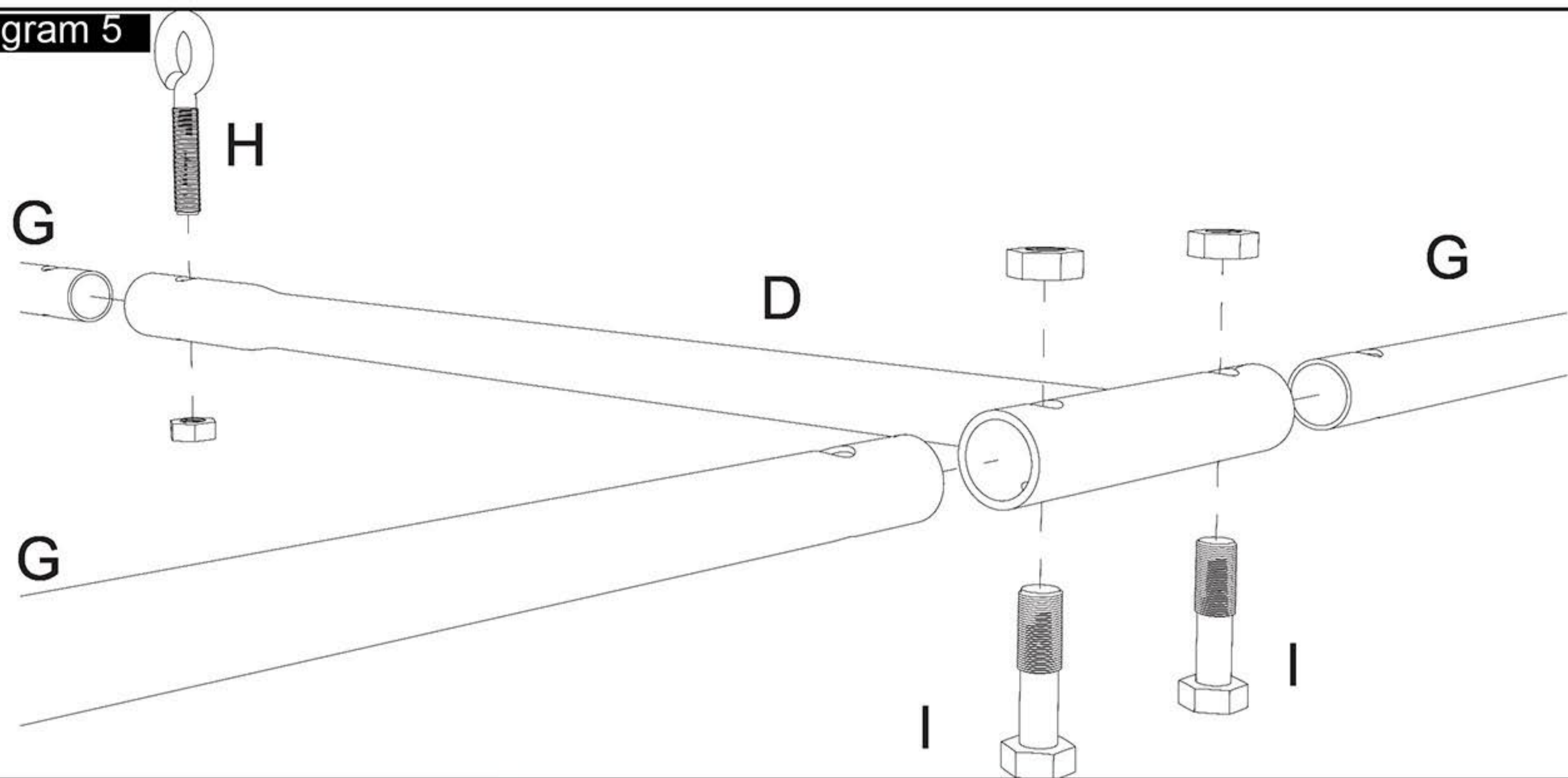

Diagram 6

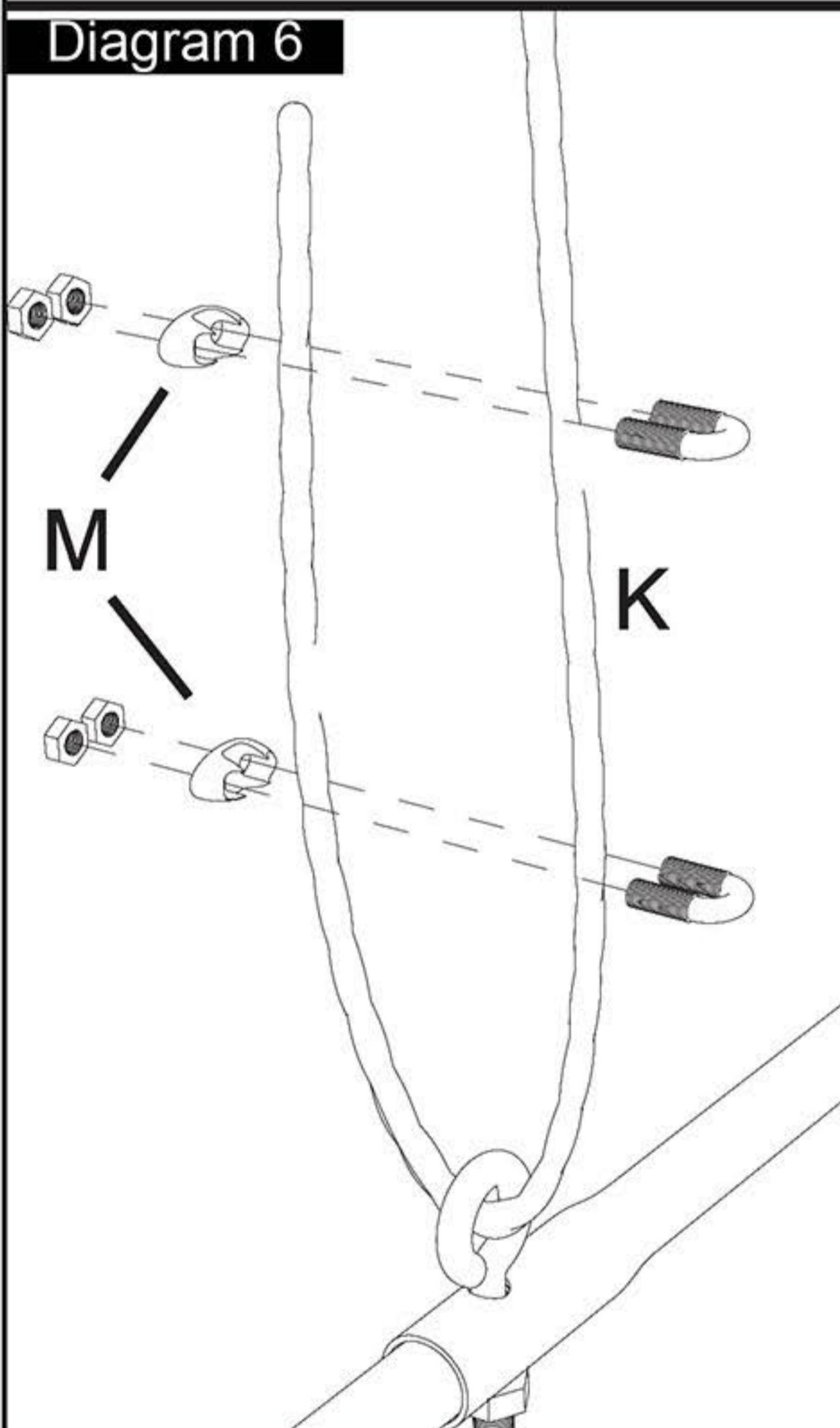

Diagram 7

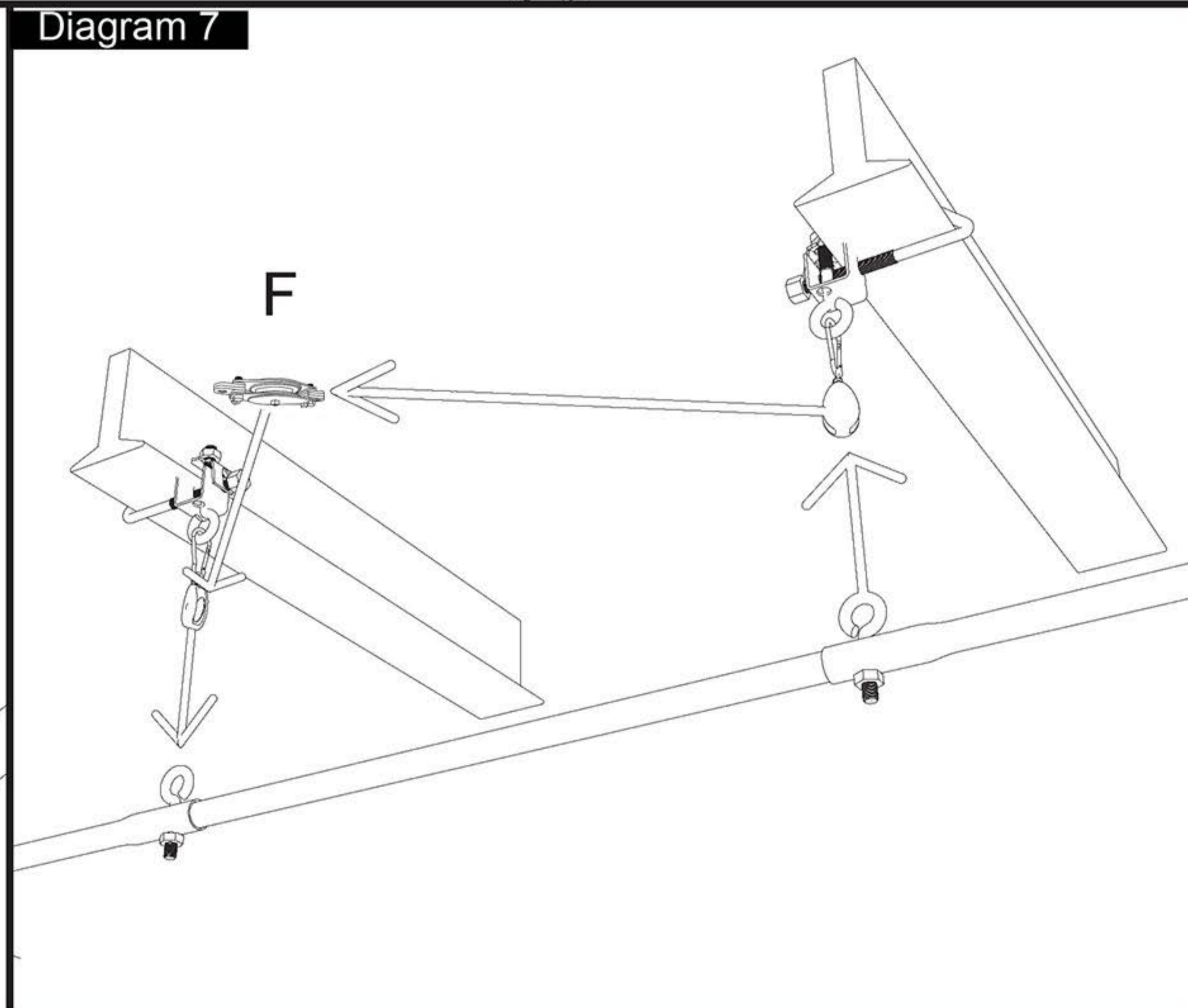

Diagram 8

