

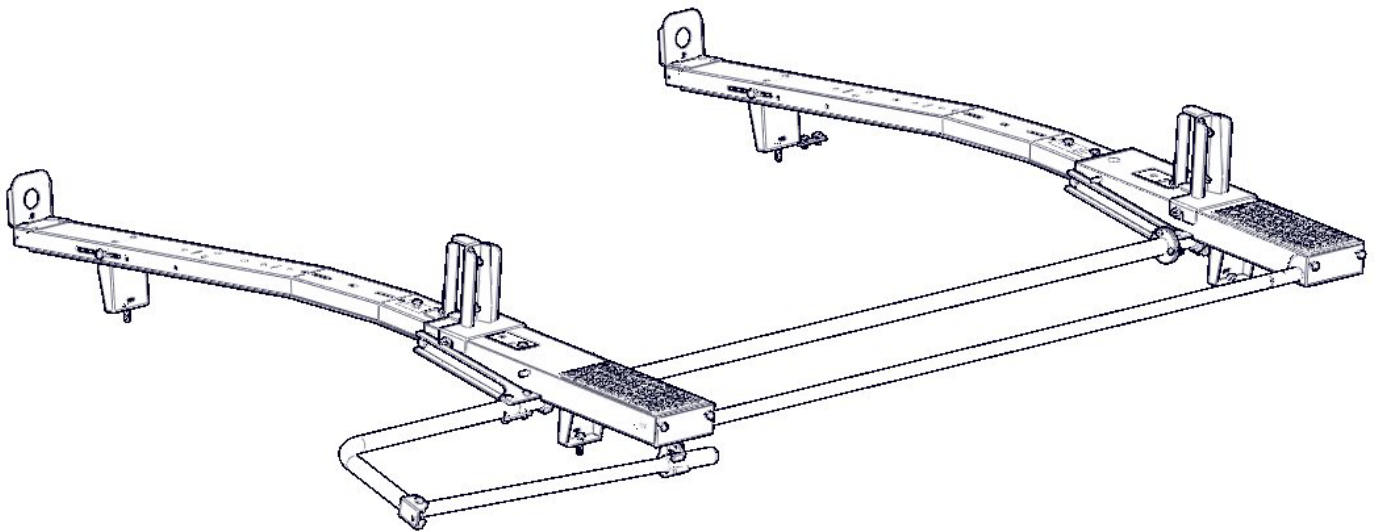

WE PUT EVERYTHING WITHIN REACH.

Installation Guide

4092L



Kargo Master
Rancho Cordova, CA 95742
800-343-7486
CustomerService@KargoMaster.com

DATE: _____

***PLEASE READ ALL INSTRUCTIONS AND WARNINGS PRIOR TO ASSEMBLING,
INSTALLING, AND USING THIS PRODUCT***

Warning



Always check for wires, fuel tanks and lines, brake lines and other important vehicle functionality items prior to drilling and installing all products.

Tools Needed

1/2" Wrench and Socket	7/16" Wrench and Socket
9/16" Wrench and Socket	Tape Measure

Table of Contents

Parts List 2

Hardware List 3

Step 1 Install Load Plate 4

Step 2 Install Front and Rear Bow Assembly 4

Step 3 Torque Tube 5

Step 4 Ladder Pan Support 6

Step 5 Ladder Stops and Hooks 7







Step 6 Install Handle 8

Step 7 Install Rack 8

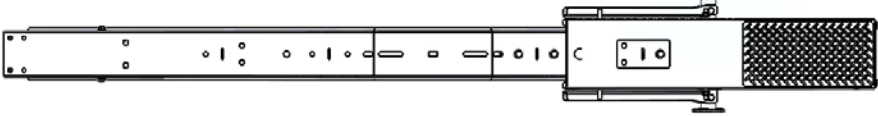
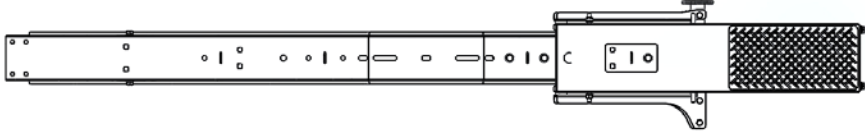

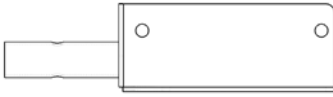

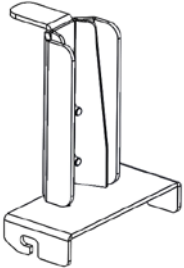
Before You Begin

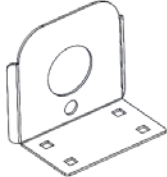
- Read all instructions.

Parts

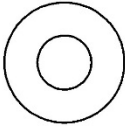
ITEM NO.	4092L PARTS	DESCRIPTION	QTY
A		Front Bow Assembly	1
B		Rear Bow Assembly	1
C		Torque Tube	1
D		Support Tube	1
E		Support Tube End	1
F		Handle	1
G		Ladder Hook	2
H		Ladder Stop	2
J		Load Plate	2
		HARDWARE	1

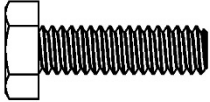
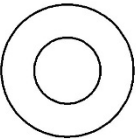
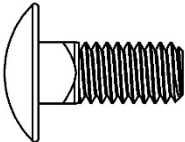
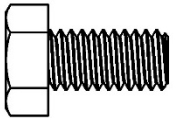
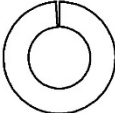
Hardware

ITEM NO.	TO SCALE	DESCRIPTION	QTY.
1		.25 flat washer	12
2		.25-20 NYLOC NUT	6
3		.25-20 x .875 HH	6
4		.312 Flat Washer	10
5		.312-18 x .75 Carriage Bolt	6
6		.312-18 x .625 HH	4
7		.312 Split Lock Washer	4
8		.312-18 Nyloc Nut	6
9		E6000	1

Step 1 – Install Load Plate

- Next bolt the Load Plate (J) on the driver side of both bows (A&B) using .312" x .75" carriage bolts (5) with .312" nyloc nuts (8) and .312" flat washers (4) as shown.
 - The "Load Plate will NOT be used if installing a double drop down rack.

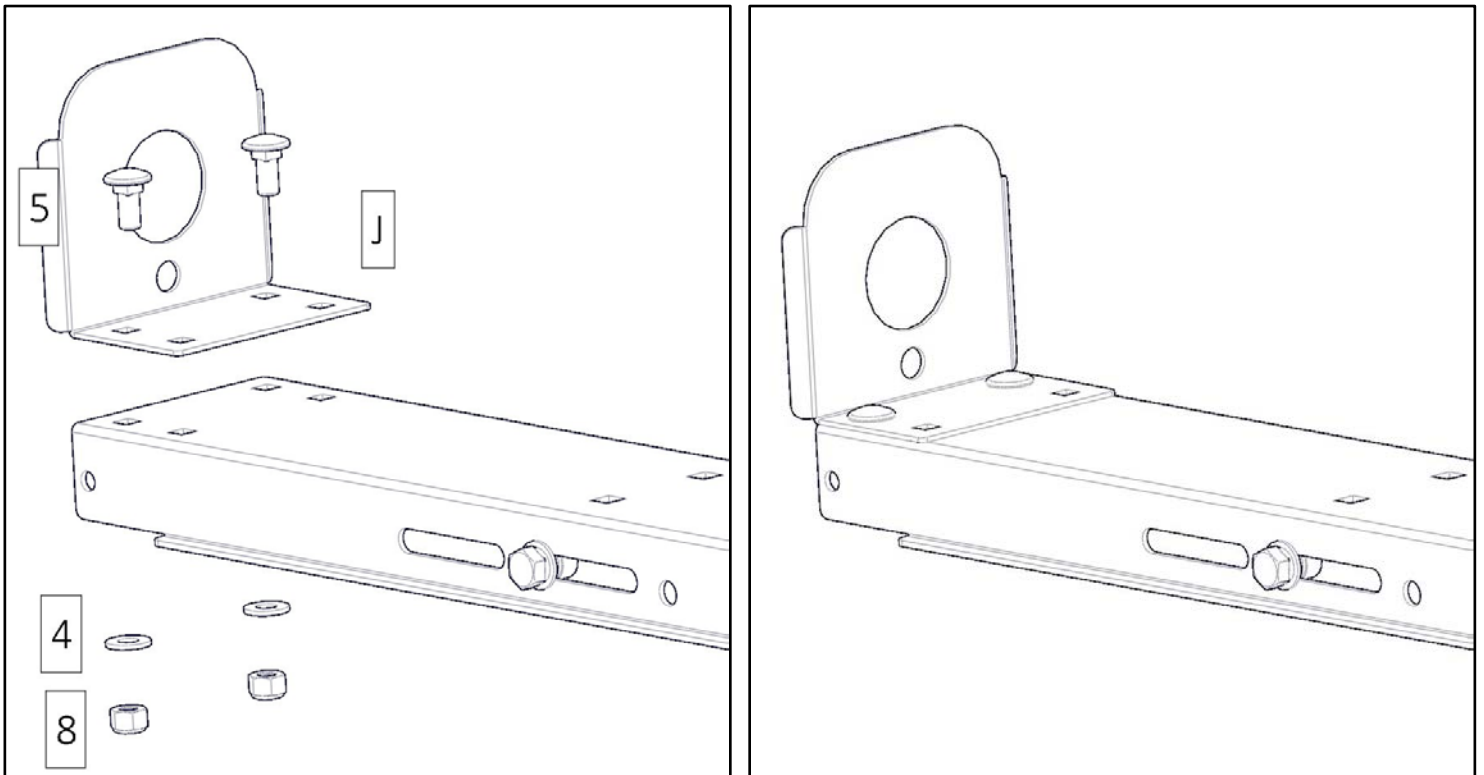

Step 2 – Install Front and Rear Bow

- Place rear bow assembly (B) onto previously installed mount feet at the rear of the Van.
 - **Make sure the bow is centered along the van**

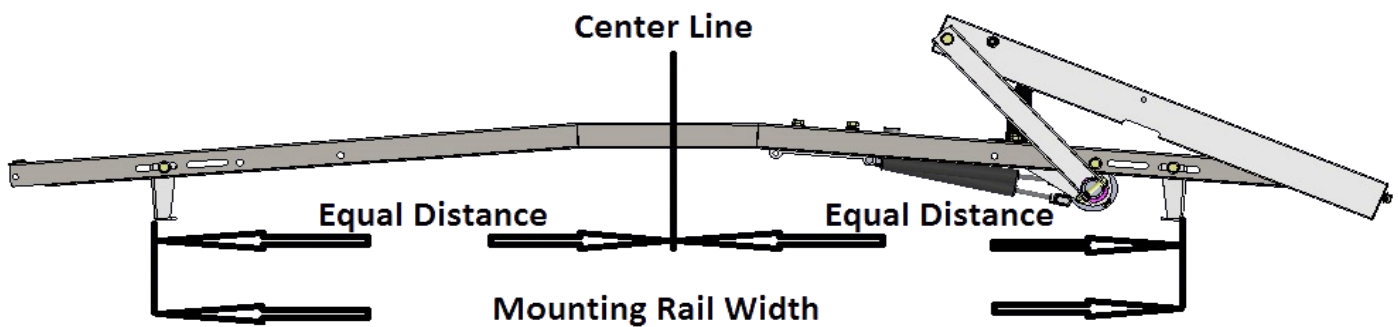

- Bolt to feet using .375" x .75" hex head bolts, .375 split lock washers and .375 flat washers.

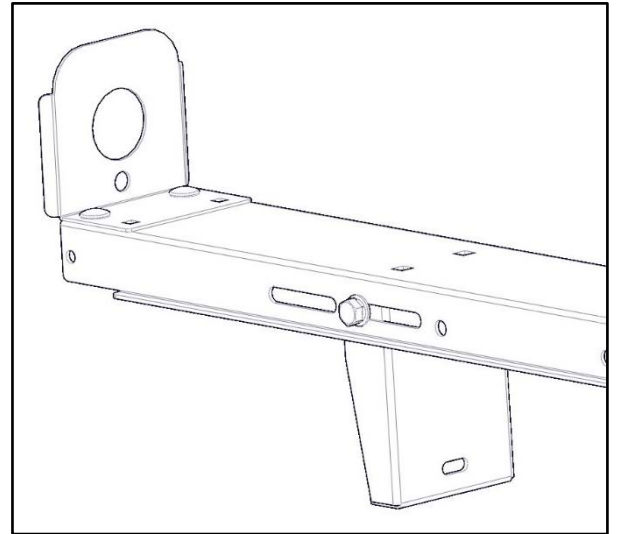
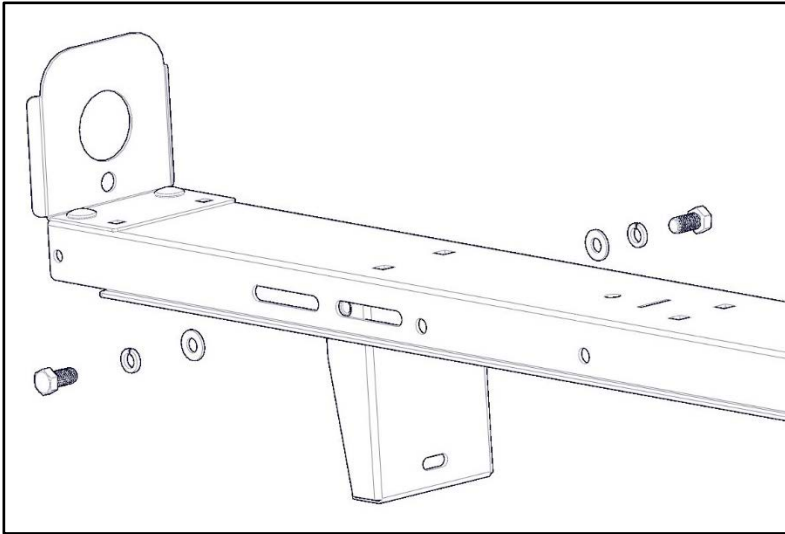

Repeat on other side.
Repeat using front bow.

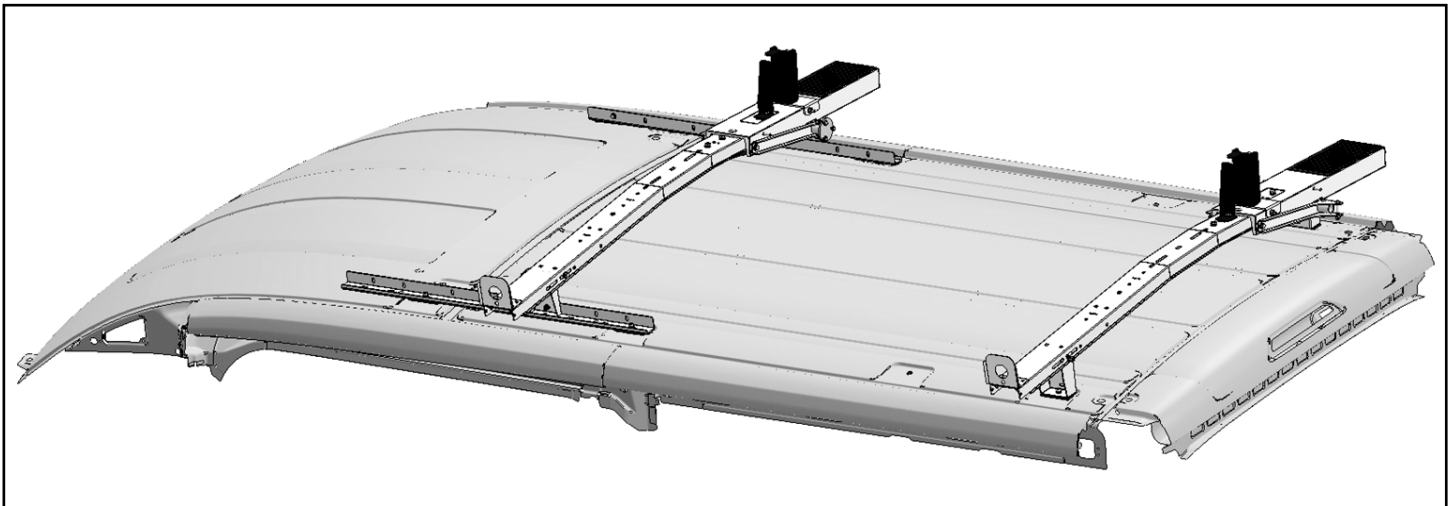

Step 3 – Torque Tube Installation

****BE SURE THE BOTH FRONT AND REAR LADDER PANS ARE ALL THE WAY DOWN ON THE BOWS WHILE TIGHTENING****

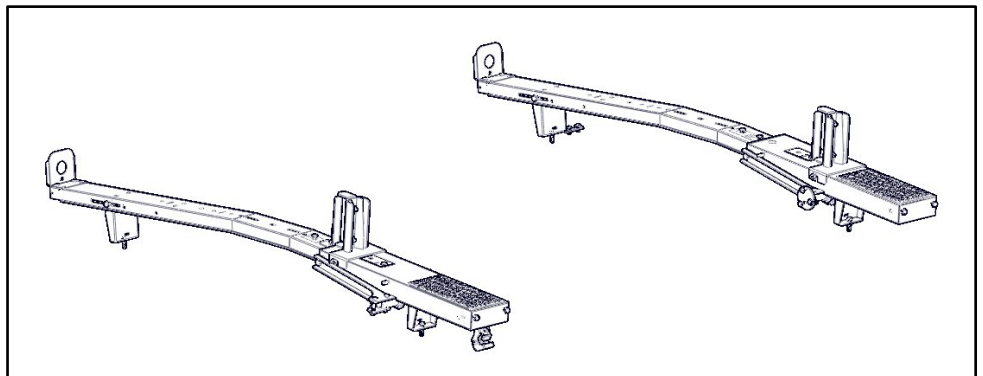

- Bolt Torque Tube(C) to Rear Bow Assy(B) using three .25" x .875" hex head bolts (3) six .25" flat washers(1) and three .25" nyloc nuts(2).

You may want to put a foam packing block under the front of torque tube (C) to make it level while tightening

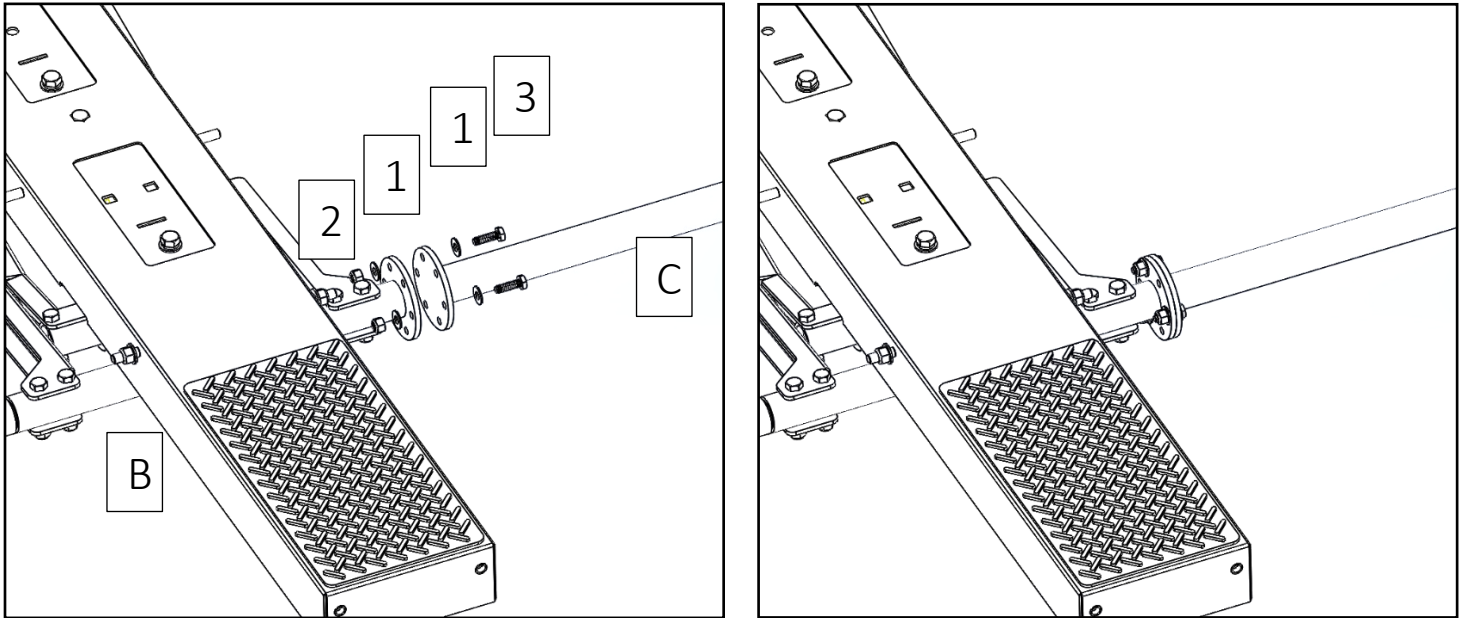

- Repeat process to bolt to the front bow assembly(A).

Step 4 – Ladder Pan Support

A.

- Assemble Support Tube(D&E). Put E6000(14) into tube swedge and around the bolt holes to prevent water from getting into tubes.

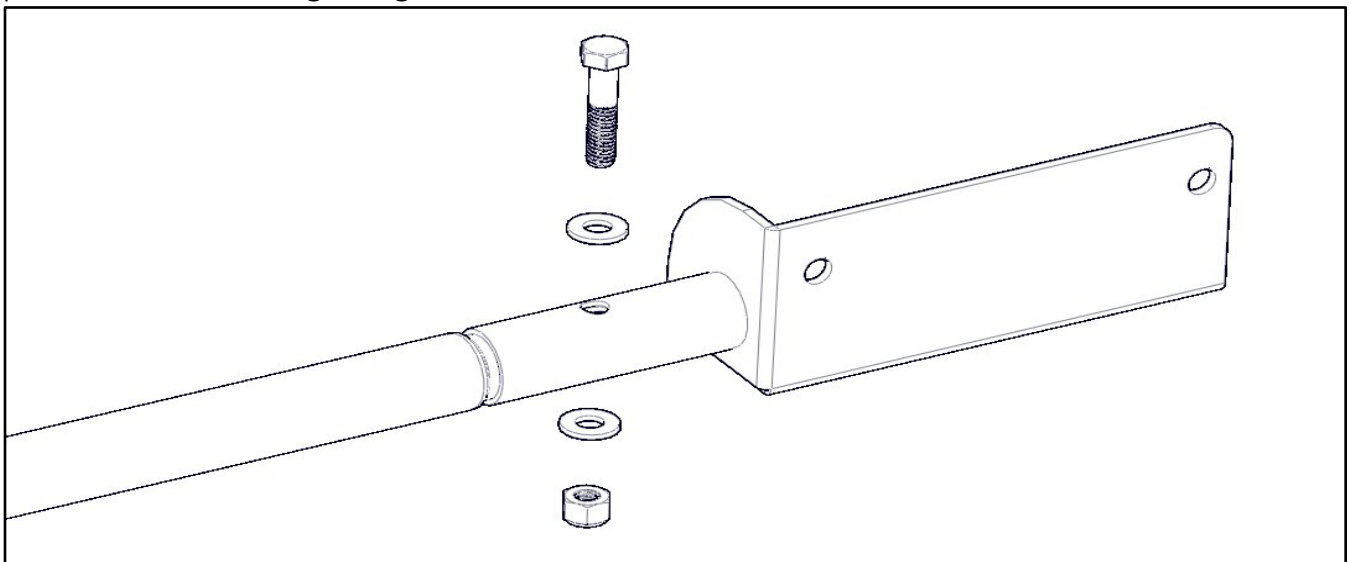

- Use .312" x 1.5" hex head, .312" flat washers and a .312" nyloc nut.

B.

- Attach Support Tube(D&E) to the Ladder pan as shown using .312" x .625 hex head (6) with .312" lock washers(7) and .312" flat washers(4).
- Repeat at front and rear bow.

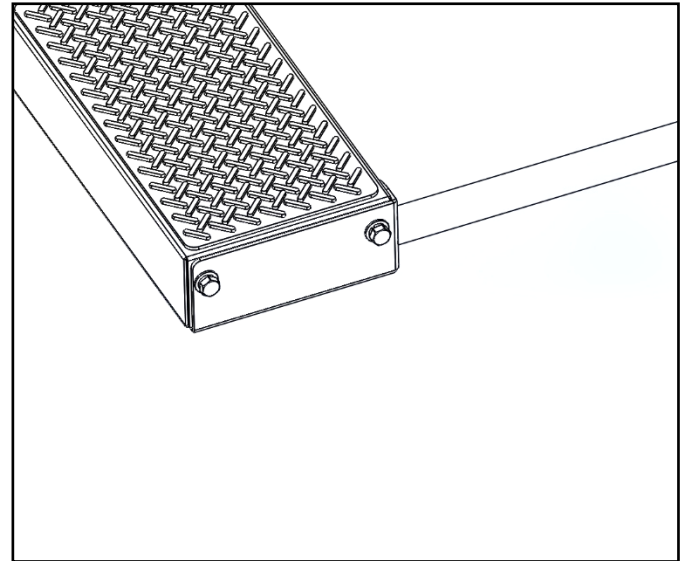
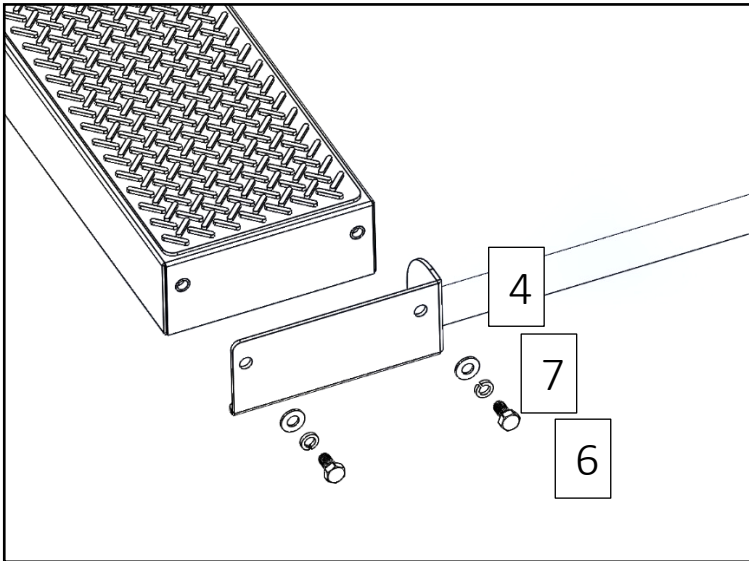

Step 5 – Ladder Stops and Hooks

- On the front bow (A), remove 3/8"x3/4" bolt, 3/8" split lock washer and 3/8" flat washer from shown location and install Ladder Stop(I)

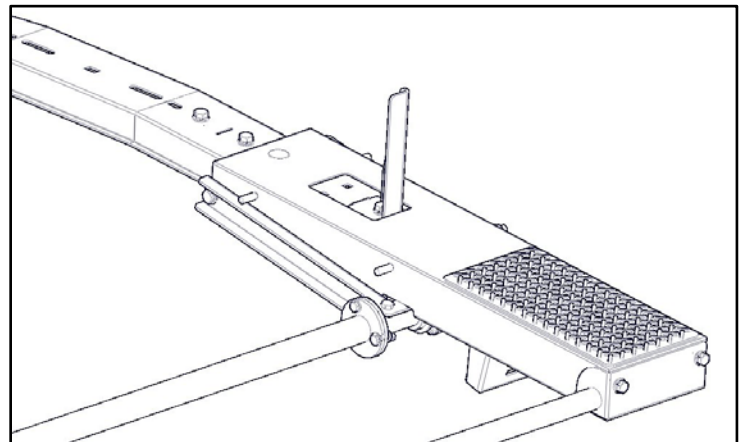
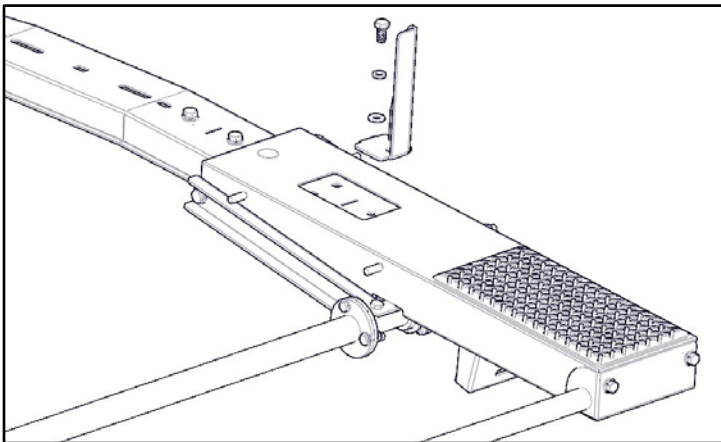

- Bolt Ladder Hook (H) to the lower position where the pem studs are installed. Use a .312 flat washer and a .312 nyloc nut .
- Repeat on both sides of ladder hook (H).

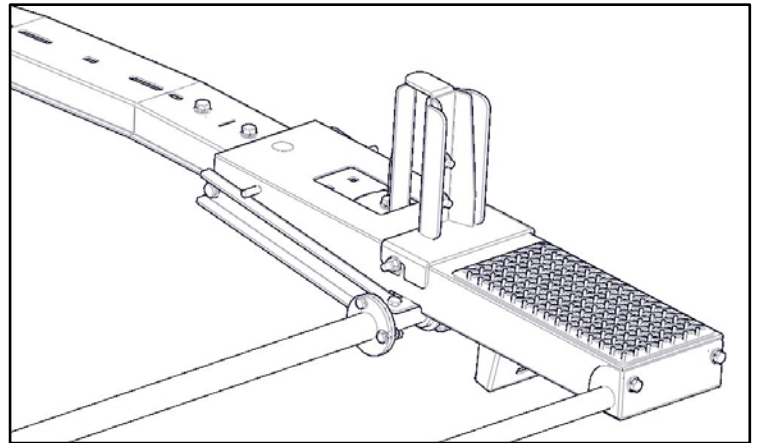
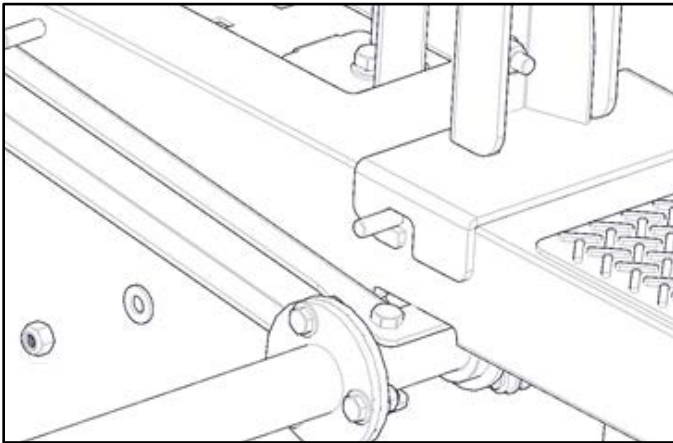

- If using an “Extension Ladder” put the Ladder Stop(I) at the same location on the Front & Rear Bow Assy.(A&B).

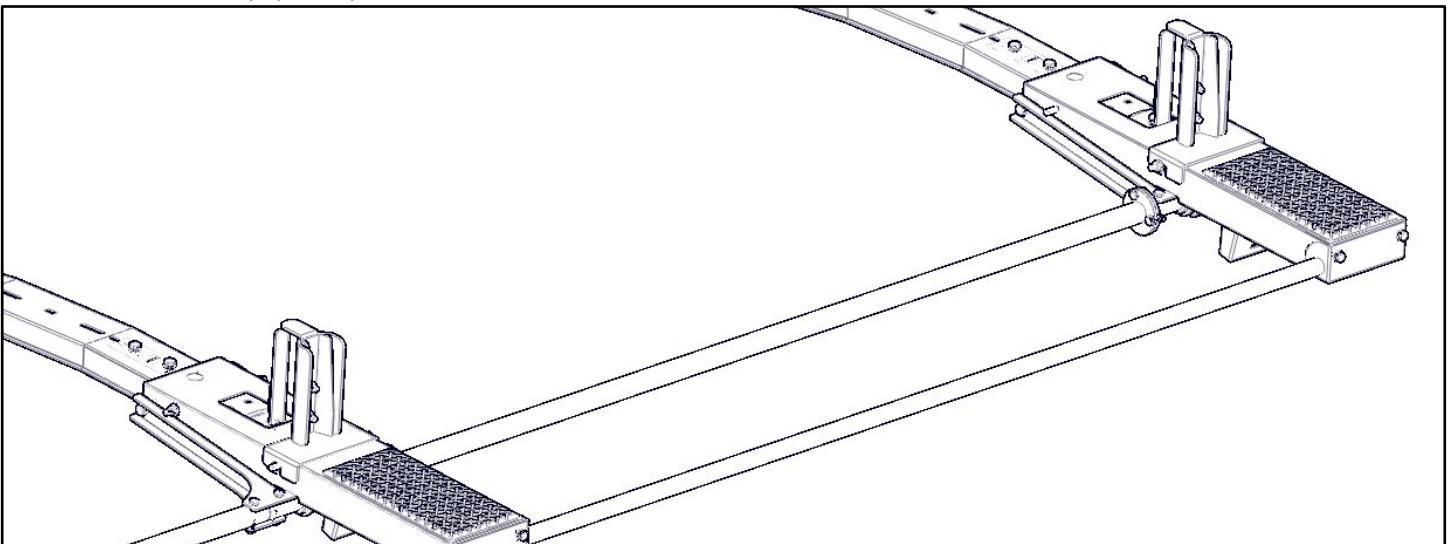

Step Ladder Set-Up

- If installing for a “Step ladder”, The ladder hook (H) and the ladder stop (I) change positions on the rear bow.
- Both of these parts move higher up on the bow and are installed using the other pem studs.

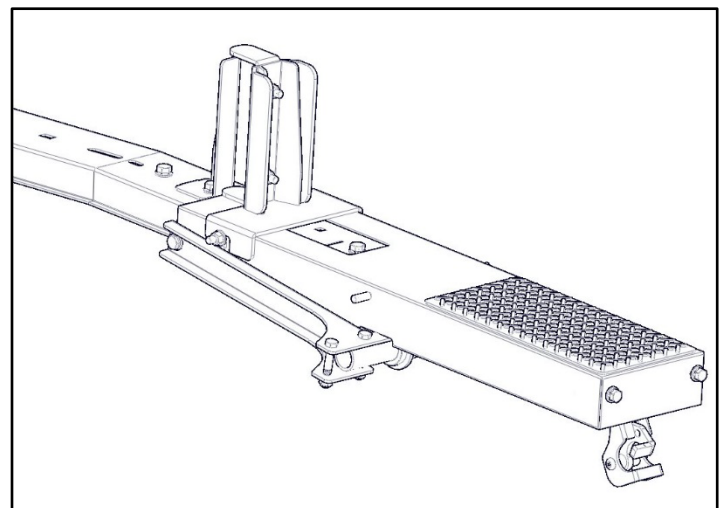
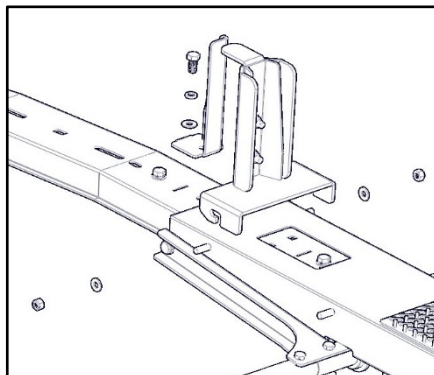

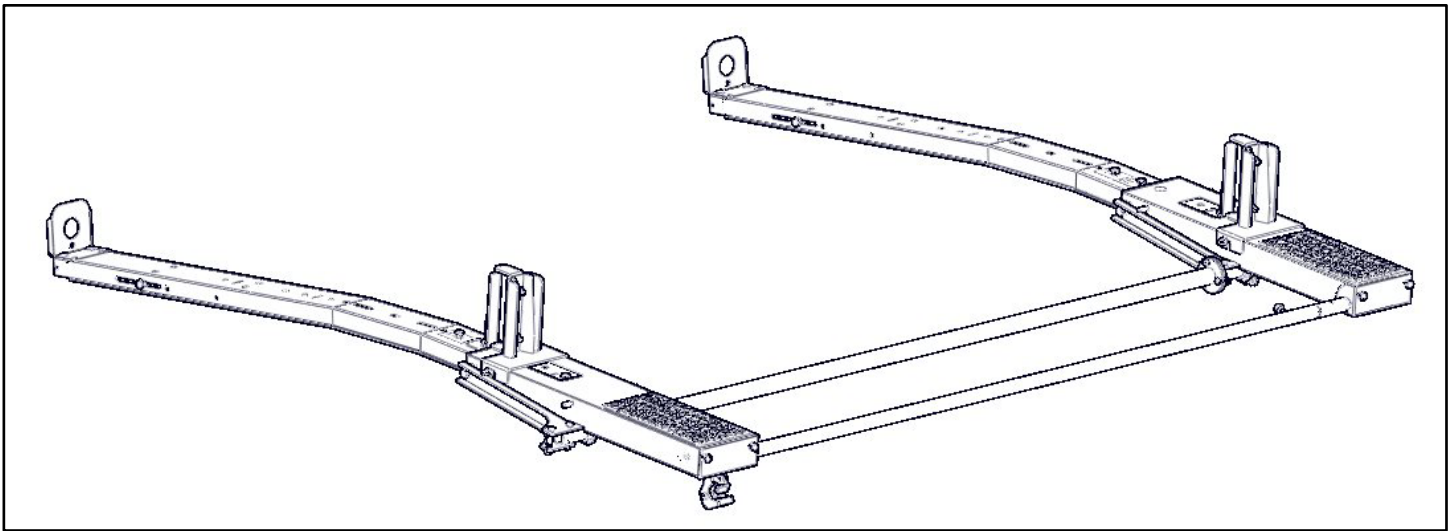

Step 6 – Installing Handle

- Attach the handle (F) to the rear bow assembly.

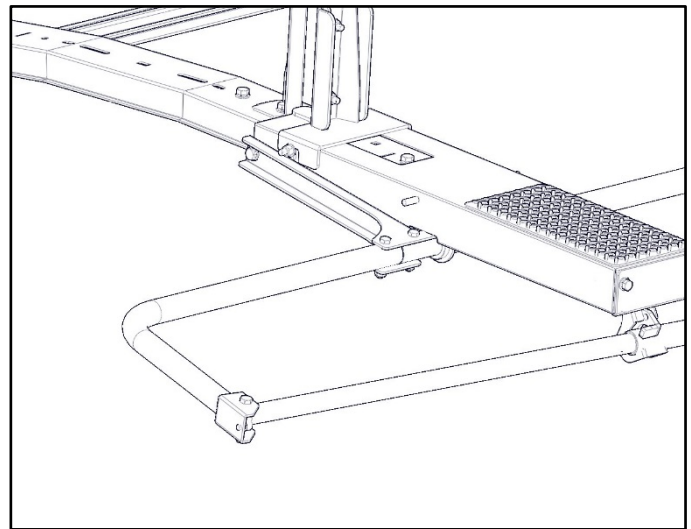
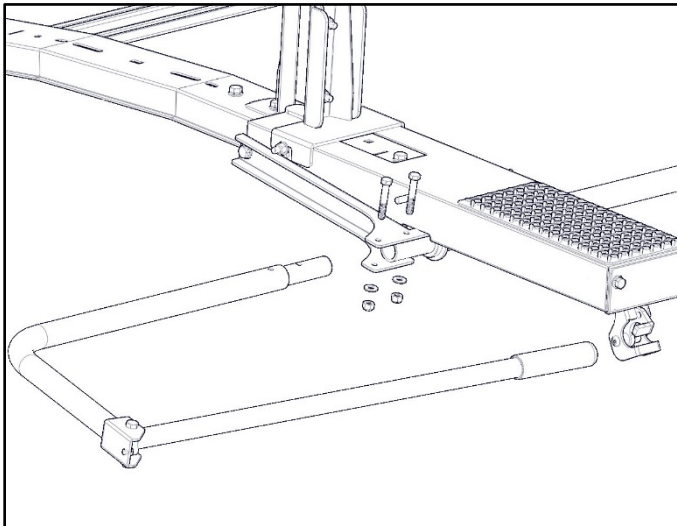

Step 7 – Installing Rack

- If you built the rack on the bench you can now set the rack on the mounts as described in the mount kit.
- See step 2 for reference.

GO BACK AND ENSURE ALL HARDWARE IS TIGHT

Your installation is now complete.