

Assembly | Asamblea | Assemblage

PO#UK000053

Customer service | Servicio al cliente | Service clientèle: 800.633.5096



Product number | Número de producto | Numéro de produit

ODI089040

Thank you for your purchase! | ¡Gracias por tu compra! | Merci pour votre achat!

Assembly | Asamblea | Assemblage

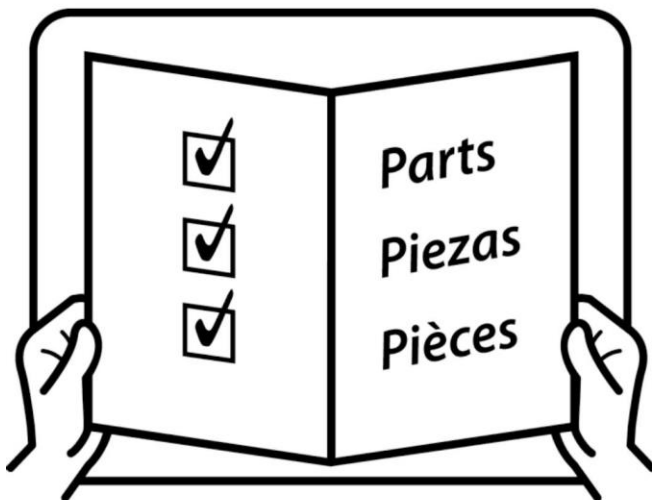
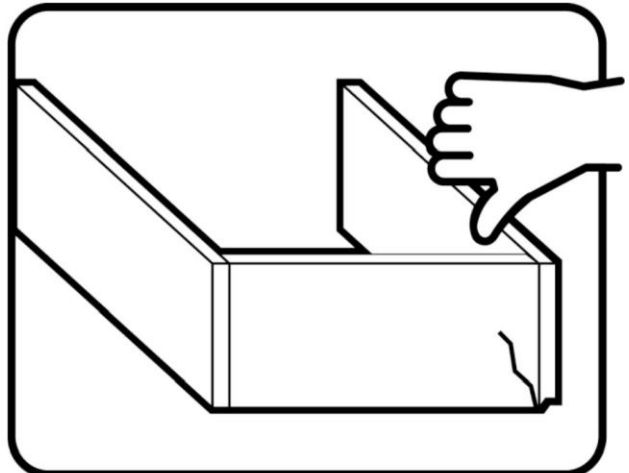
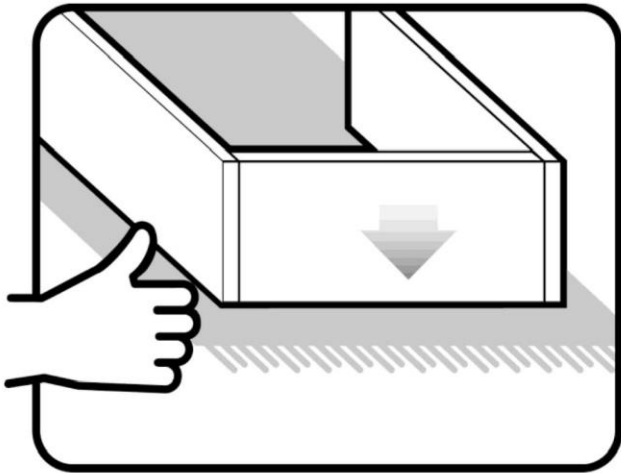
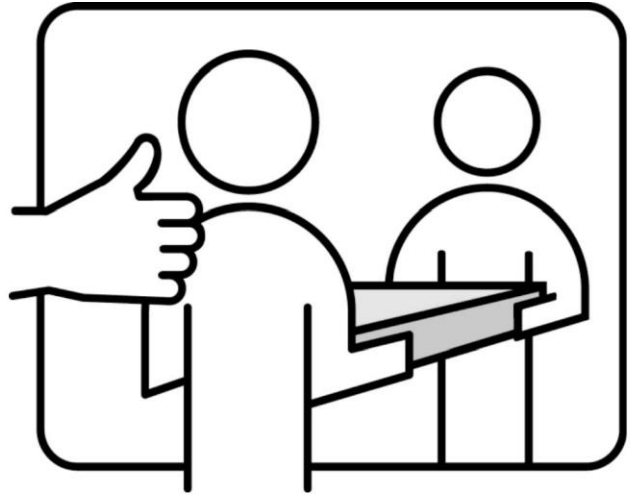
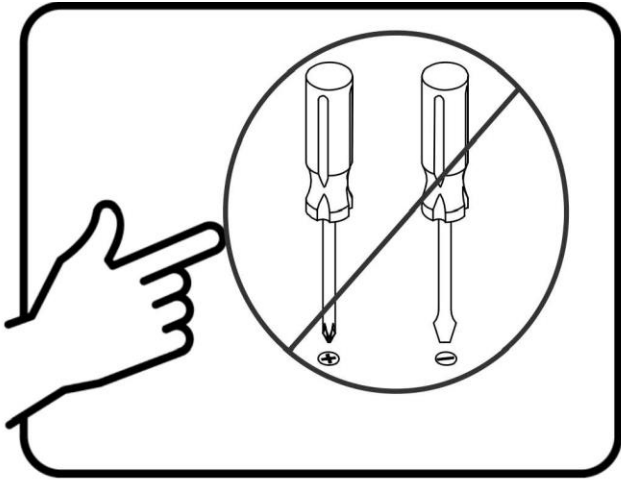

Assembly | Asamblea | Assemblage

Techniques | Técnicas | Techniques

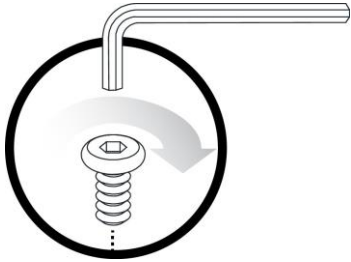

Care | Cuidado | Entretien













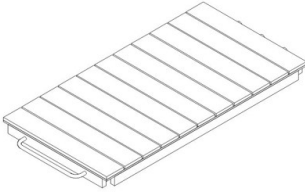

Safety | Seguridad | Sécurité





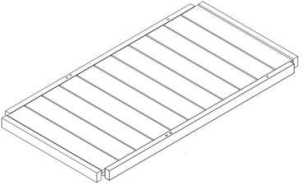

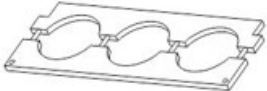

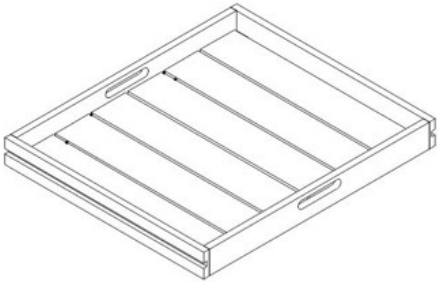
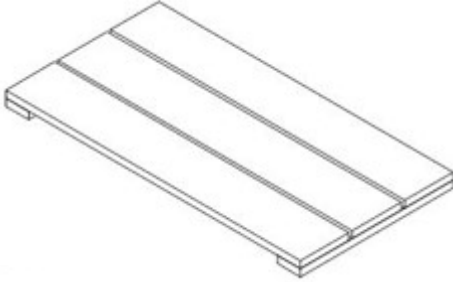

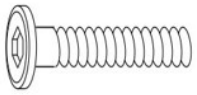

Note! | ¡Nota! | Remarque!

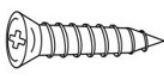

Assembly | Asambla | Assemblage

<p>A x1</p>  <p>Top panel Panel superior Panneau du haut</p>	<p>B x1</p>  <p>Leg Pierna Jambe</p>	<p>C x1</p>  <p>Leg Pierna Jambe</p>	<p>D x1</p>  <p>Leg Pierna Jambe</p>
<p>E x2</p>  <p>Slider Deslizador Curseur</p>	<p>F x1</p>  <p>Leg Pierna Jambe</p>	<p>G x1</p>  <p>Middle leg Pierna media Jambe moyenne</p>	<p>H x1</p>  <p>Middle leg Pierna media Jambe moyenne</p>
<p>I x1</p>  <p>Bottom panel Panel inferior Panneau du bas</p>	<p>J x2</p>  <p>Short bar Barra corta Barre courte</p>	<p>K x1</p>  <p>Bottle holder Sostenedor de botella Porte bouteille</p>	<p>L x2</p>  <p>Wheel Rueda Roue</p>
<p>M x1</p>  <p>Tray Bandeja Plateau</p>		<p>N x2</p>  <p>Shelf Estante Étagère</p>	

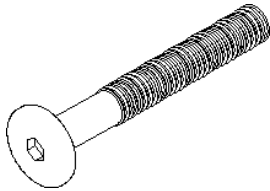
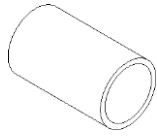

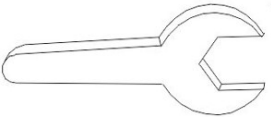
Assembly | Asamblea | Assemblage

<p>1 x8</p> <p>1/4 x 1 3/8"</p>  <p>Bolt Tornillo Boulon</p>	<p>2 x6</p> <p>1/6 x 1/2"</p>  <p>Screw Tornillo Vis</p>	<p>3 x2</p>  <p>1/6 x 1 1/8"</p> <p>Screw Tornillo Vis</p>	<p>4 x4</p>  <p>1/6 x 2"</p> <p>Screw Tornillo Vis</p>
<p>5 x2</p>  <p>Washer Arandela Rondelle</p>	<p>6 x4</p>  <p>Washer Arandela Rondelle</p>	<p>7 x8</p>  <p>Washer Arandela Rondelle</p>	<p>8 x2</p>  <p>Spring washer Arandela de resorte Rondelle à ressort</p>
<p>9 x2</p>  <p>Nut Tuerca Écrou</p>	<p>10a x2</p>  <p>Wheel bolt Tornillo de rueda Boulon de roue</p>	<p>10b x2</p>  <p>Sleeve Manga Manche</p>	<p>11 x1</p>  <p>Allen wrench Llave Allen Clé Allen</p>
<p>12 x1</p>  <p>Spanner wrench Llave Inglesa Clé à molette</p>			

Assembly | Asambla | Assemblage

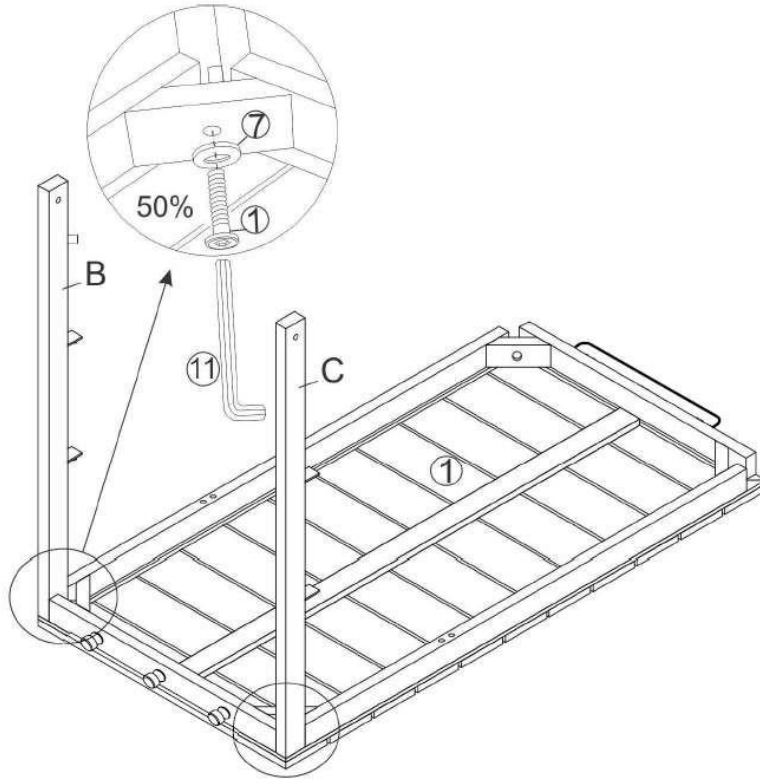

1

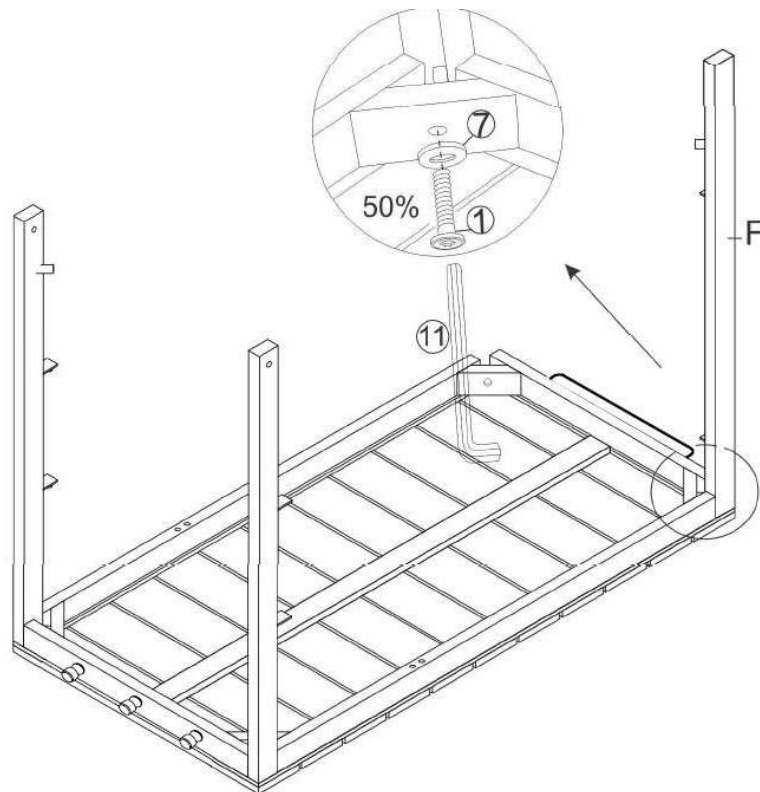

1		x2
7		x2
11		x1

2



1		x1
7		x1
11		x1

Assembly | Asamblea | Assemblage

3

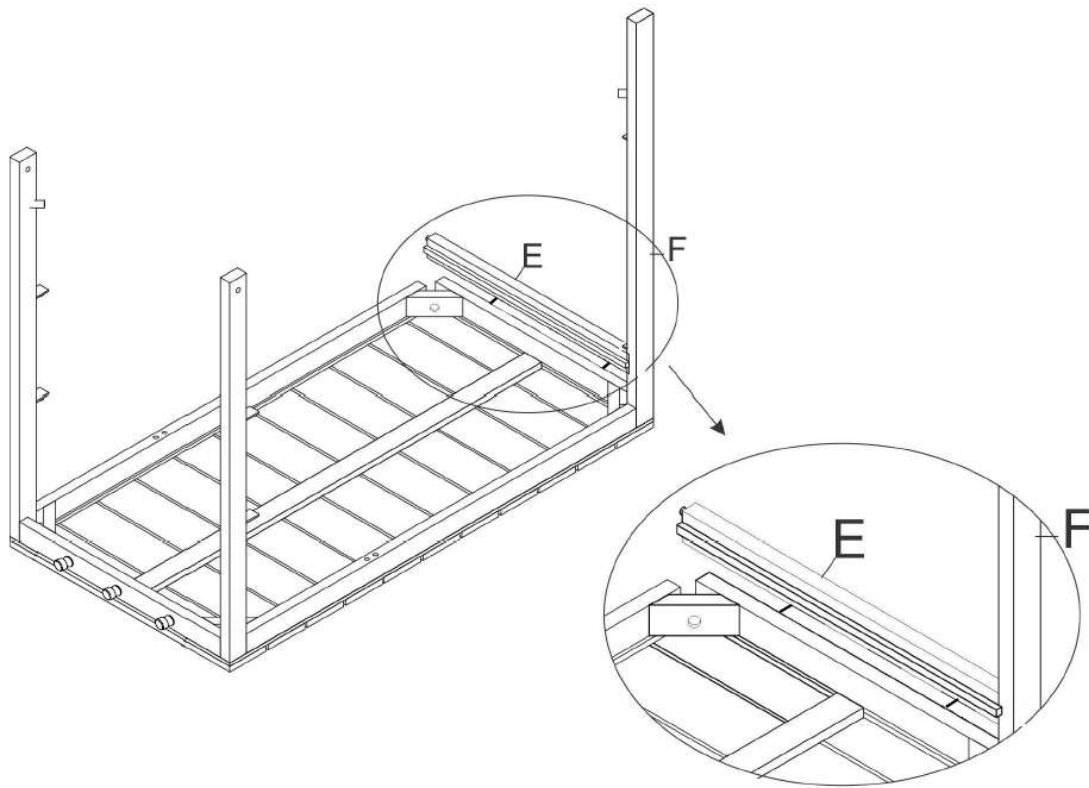

4

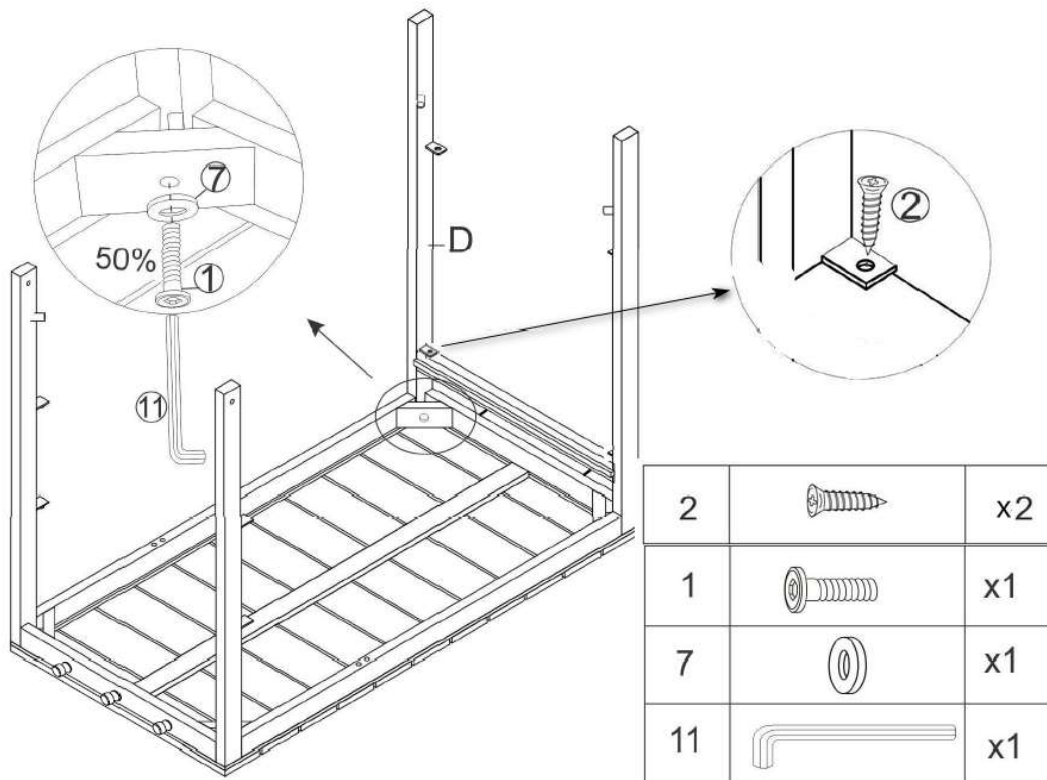

Do not over-tighten screws.
No apriete demasiado los tornillos.
Ne pas trop serrer les vis.

Assembly | Asambla | Assemblage

5

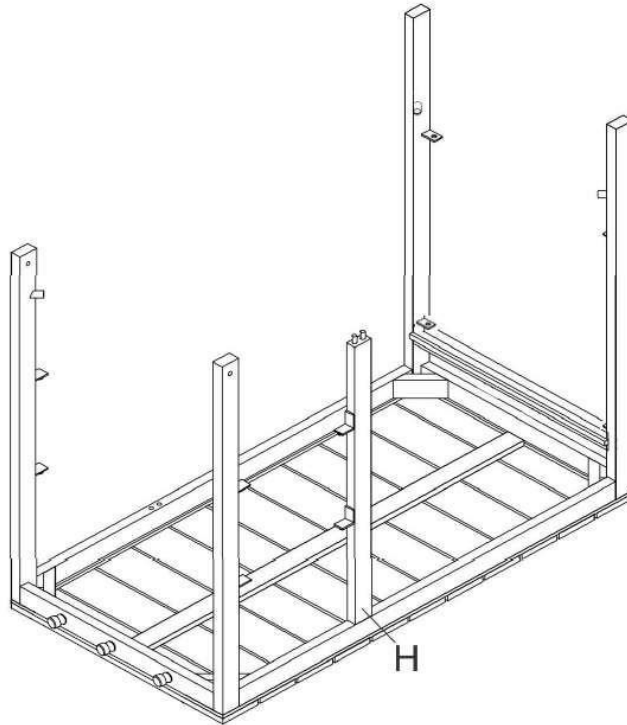

6

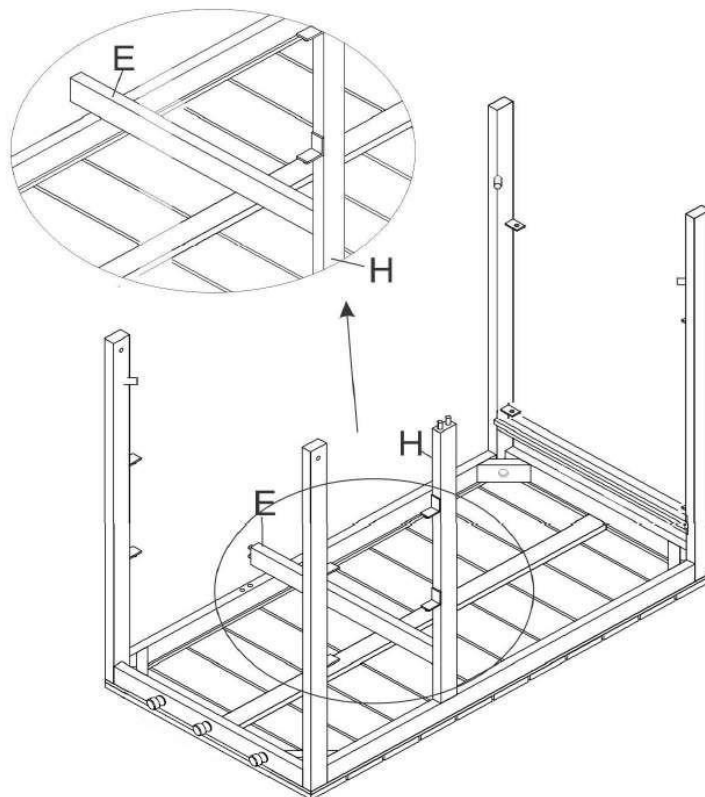

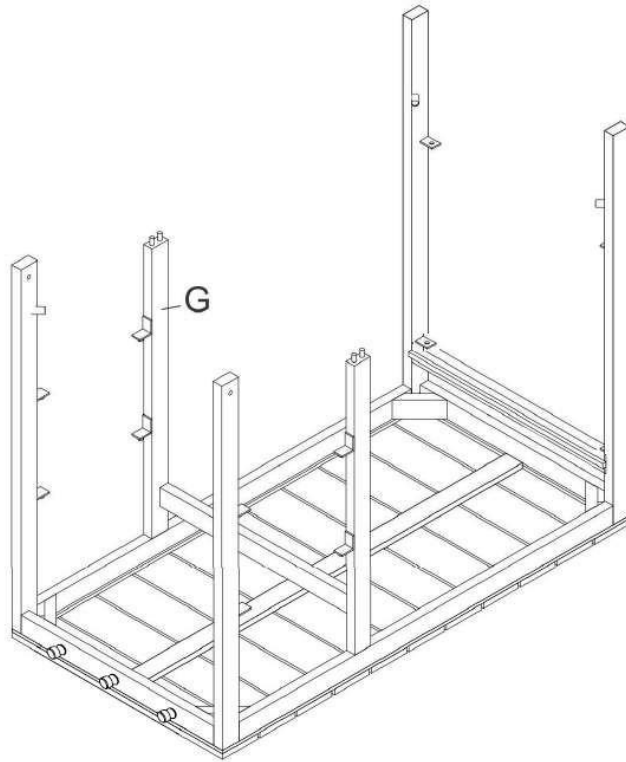

Assembly | Asambla | Assemblage

7

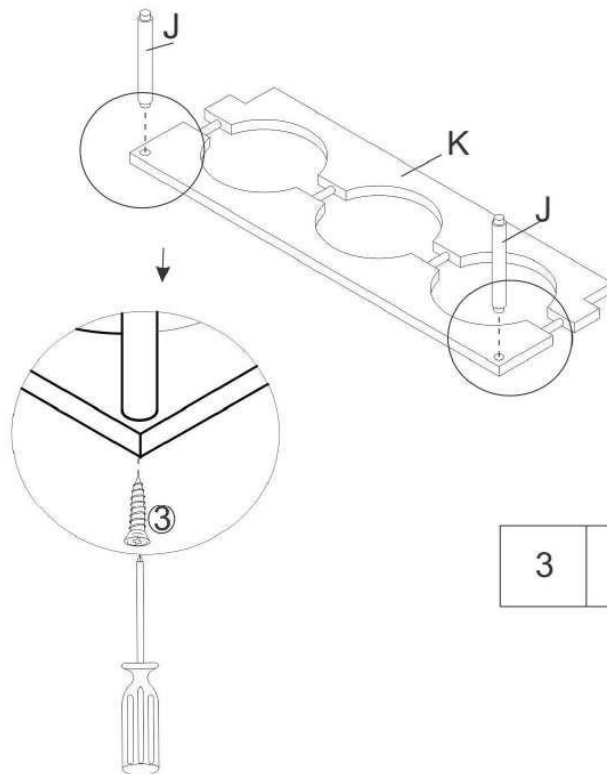

8



3		x2
---	---	----

Assembly | Asambla | Assemblage



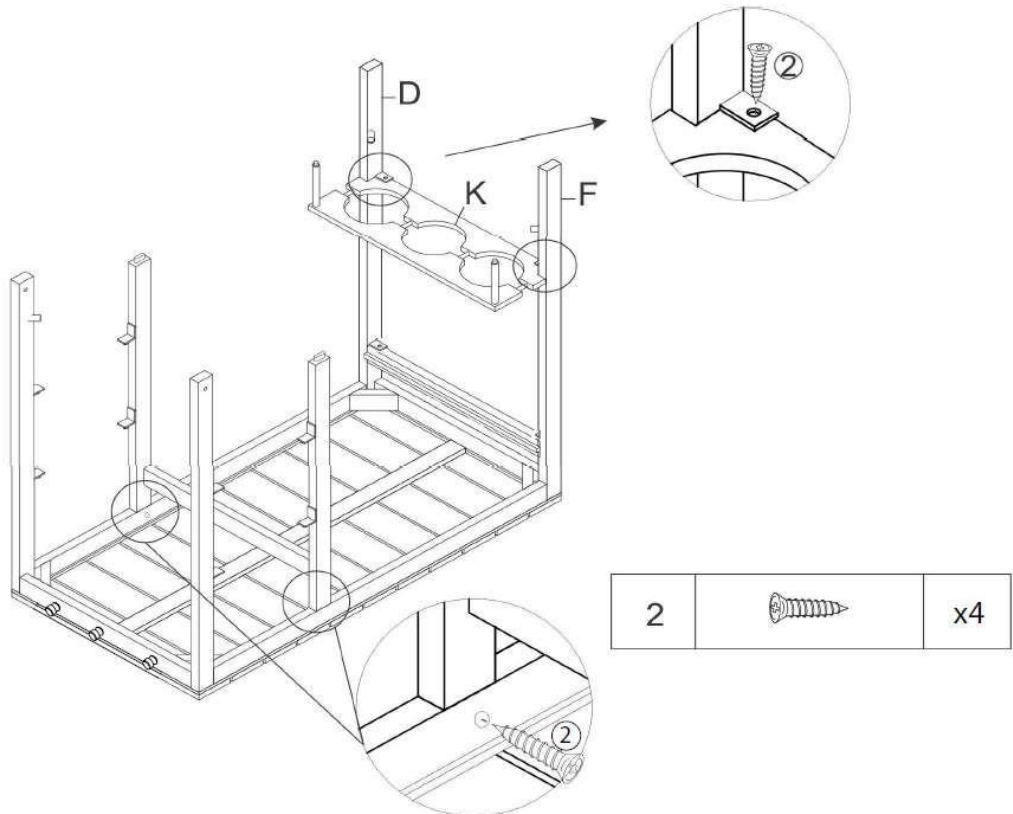

9

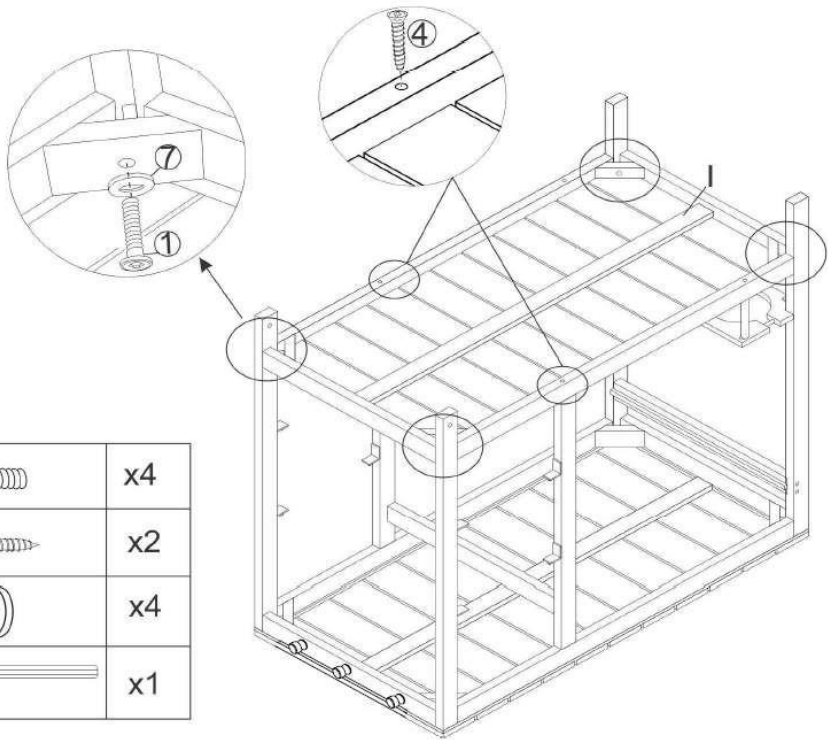

2		x4
---	---	----

10



1		x4
4		x2
7		x4
11		x1

Assembly | Asamblea | Assemblage

11

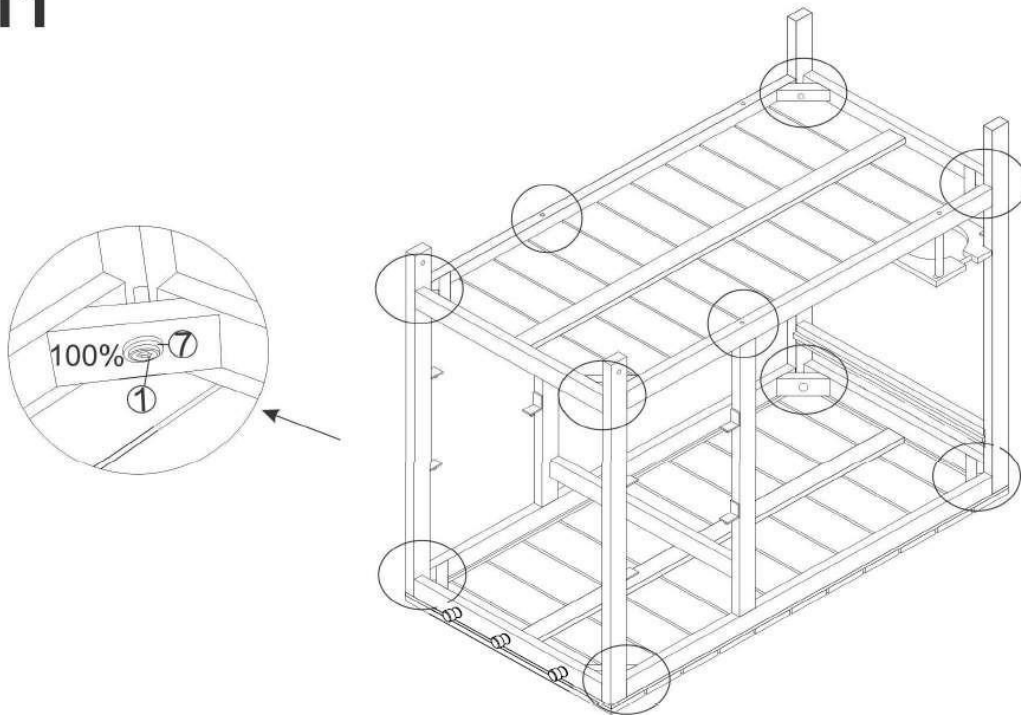

12

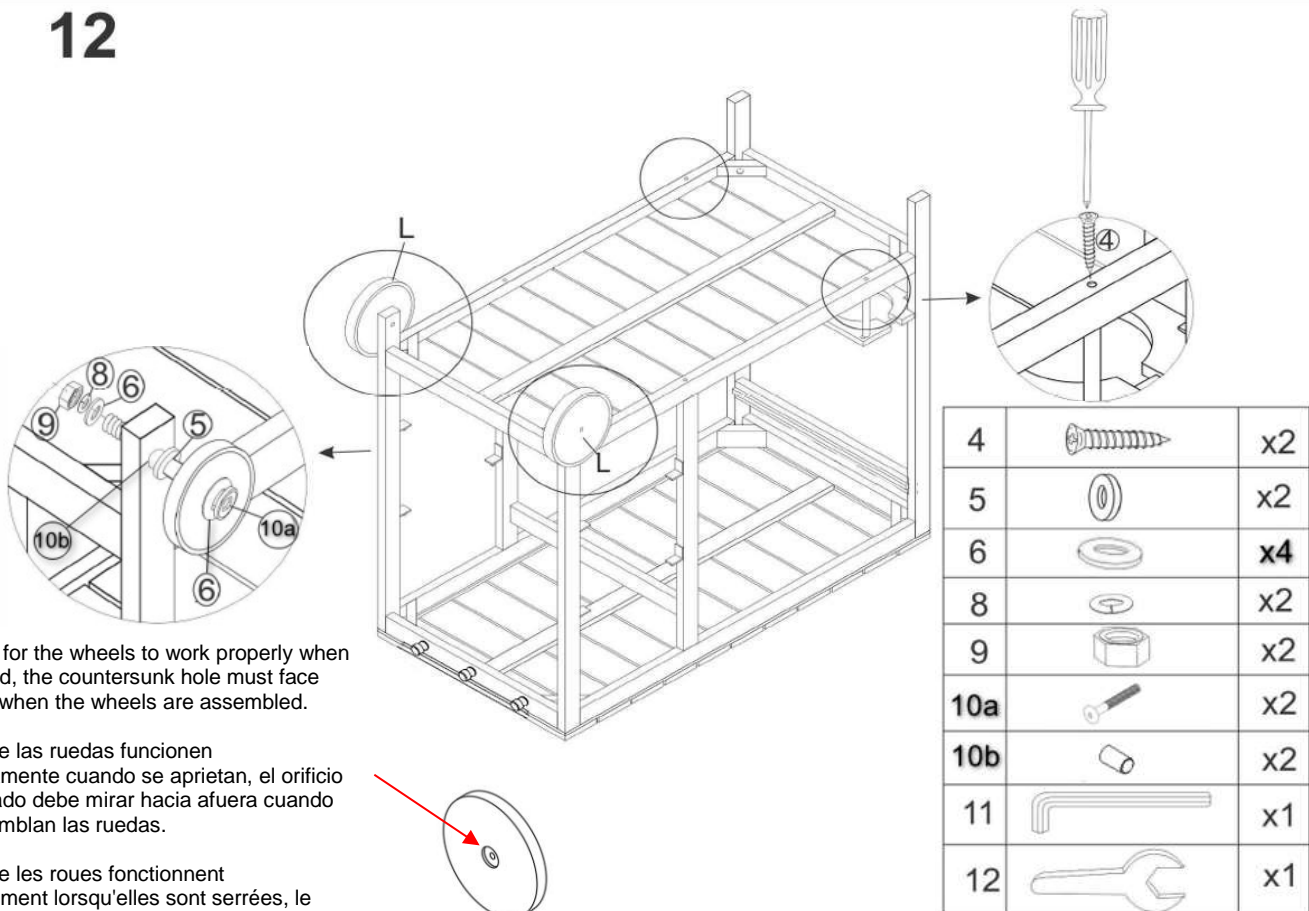

In order for the wheels to work properly when tightened, the countersunk hole must face outside when the wheels are assembled.

Para que las ruedas funcionen correctamente cuando se aprietan, el orificio avellanado debe mirar hacia afuera cuando se ensamblan las ruedas.

Pour que les roues fonctionnent correctement lorsqu'elles sont serrées, le trou fraisé doit être orienté vers l'extérieur lorsque les roues sont assemblées.

Assembly | Asambla | Assemblage

13

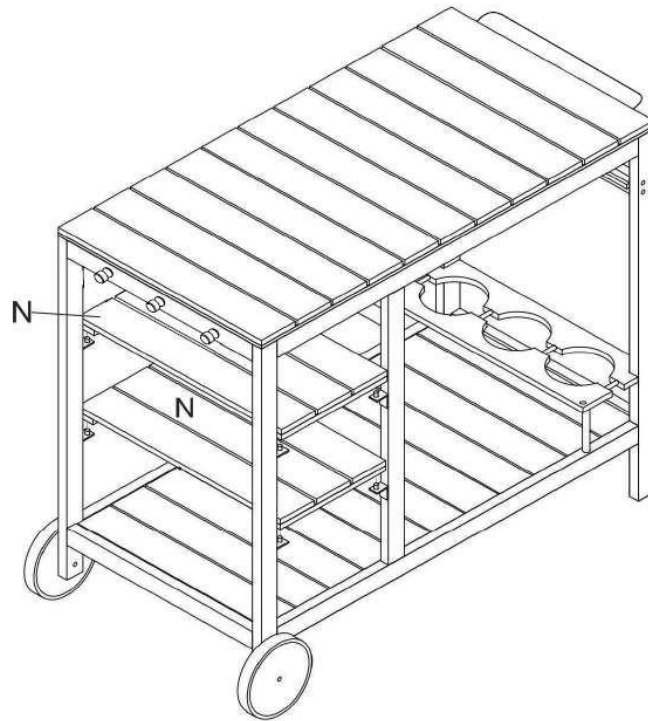

14

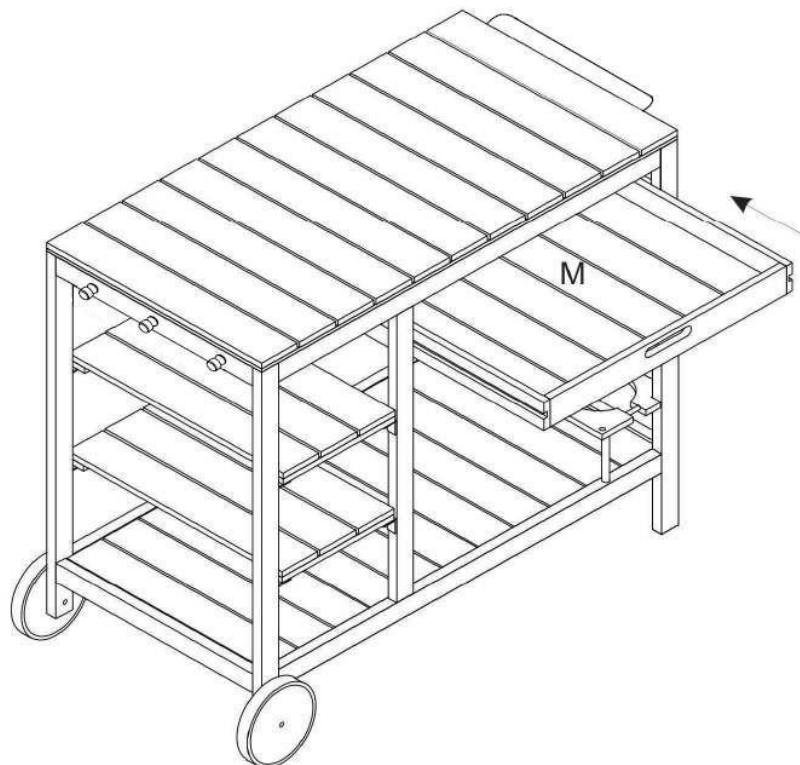

Assembly | Asambla | Assemblage



**May We Help You?
800.633.5096**

Please have this information ready when you call:

- Item Number
- PO#
- Purchaser Name
- Place of Purchase
- Purchase Date
- Date Product Arrived

Immediately examine this product carefully. Any request for missing or damaged part replacement must be received within 1 year of your receipt of the product. Requests for replacement parts, if available, will be honored within this time frame. Parts will not be available for items arriving fully assembled. We do not recommend modifying products and we are not responsible for any damages due to product modifications. If damages or missing parts are not reported within 1 year of receiving the product, we are under no obligation to provide parts or replacement merchandise. For product issues, please contact customer service at 800-633-5096 (toll-free) Mon-Fri 8:30am - 5pm CST. Please ask for a customer service representative for issues involving damages or replacement parts. Please ask for a technical assistance representative for any issues related to product assembly/construction.

Regarding product returns, please contact the retailer from whom you purchased the product.

For items purchased in a retail store, you will need to contact the retailer for all part needs.

Items purchased in a retail store or from a website under the following conditions are purchased as is and warranty will not be provided:

- Like new
- Open box
- Used
- As is

Items purchased from garage sales, resale stores, auctions, or individuals and are missing a component or part are not covered by warranty.

**Podemos ayudarle?
800.633.5096**

Tenga a mano esta información cuando llame:

- Numero de artículo
- PO#
- Nombre del comprador
- Lugar de compra
- Fecha de compra
- Fecha en que llegó el producto

Inmediatamente examine este producto con cuidado. Cualquier solicitud de reemplazo de pieza faltante o dañada debe recibirse dentro de 1 año de haber recibido el producto. Las solicitudes de repuestos, si están disponibles, serán atendidas dentro de este marco de tiempo. Las piezas no estarán disponibles para los artículos que lleguen completamente ensamblados. No recomendamos modificar los productos y no nos hacemos responsables de los daños debidos a las modificaciones del producto. Si no se informan daños o piezas faltantes dentro de 1 año de recibir el producto, no tenemos la obligación de proporcionar piezas o mercancía de reemplazo. Para problemas con el producto, comuníquese con el servicio al cliente al 800-633-5096 (sin cargo) de lunes a viernes, de 8:30 a.m. a 5 p.m. CST. Solicite a un representante de servicio al cliente si tiene problemas con daños o piezas de repuesto. Solicite un representante de asistencia técnica para cualquier problema relacionado con el montaje/construcción del producto.

Con respecto a las devoluciones de productos, comuníquese con el minorista al que le compró el producto.

Para los artículos comprados en una tienda minorista, deberá comunicarse con el minorista para todas las necesidades de piezas.

Los artículos comprados en una tienda minorista o en un sitio web bajo las siguientes condiciones se compran tal cual y no se proporcionará garantía:

- Como nuevo
- Abrir caja
- Usado
- Como es

Los artículos comprados en ventas de garaje, tiendas de reventa, subastas o particulares y les falta un componente o pieza no están cubiertos por la garantía.

**Pouvons-nous vous aider?
800.633.5096**

Veillez avoir cette information a portée de main lorsque vous appelez:

- Numero d'article
- PO#
- Nom de l'acheteur
- Lieu d'achat
- Date d'achat
- Date d'arrivée du produit

Immédiatement examiner ce produit soigneusement. Toute demande de remplacement de pièce manquante ou endommagée doit être reçue dans l'année suivant la réception du produit. Les demandes de pièces de rechange, si elles sont disponibles, seront honorées dans ce délai. Les pièces ne seront pas disponibles pour les articles arrivant complètement assemblés. Nous ne recommandons pas de modifier les produits et nous ne sommes pas responsables des dommages causés par des modifications du produit. Si des dommages ou des pièces manquantes ne sont pas signalés dans l'année suivant la réception du produit, nous ne sommes pas tenus de fournir des pièces ou des marchandises de remplacement. En cas de problème avec le produit, veuillez contacter le service client le 800-633-5096 (sans frais) du lundi au vendredi de 8h30 à 17h, heure de Paris. S'il vous plaît demander à un représentant du service clientèle pour les problèmes impliquant des dommages ou des pièces de rechange. Veuillez demander à un représentant de l'assistance technique de résoudre tout problème lié à l'assemblage/la construction du produit.

En ce qui concerne les retours de produits, veuillez contacter le détaillant chez qui vous avez acheté le produit.

Pour les articles achetés dans un magasin de détail, vous devrez contacter le détaillant pour tous les besoins en pièces.

Les articles achetés dans un magasin de détail ou sur un site Web dans les conditions suivantes sont achetés tels quels et la garantie ne sera pas fournie:

- Comme neuf
- Boîte ouverte
- Utilisé
- Comme si

Les articles achetés dans des vide-greniers, des magasins de revente, des ventes aux enchères ou des particuliers et auxquels il manque un composant ou une pièce ne sont pas couverts par la garantie.