

### Features

- Curved basin creates a comfortable bathing experience.
- Integral flange helps prevent water from seeping behind wall and simplifies alcove installation.
- Textured bottom surface.

### Material

- Acrylic.

### Installation

- Left drain.
- Alcove.

### Recommended Products/Accessories

- K-7161-AF 1-1/2" adjustable pop-up drain above- or through-floor
- K-7213 27" Cable Bath Drain
- K-7214 27" Cable Bath Drain
- K-23726 Drain treatment
- K-23732 Tub & shower cleaner



### Codes/Standards

- CSA B45.5/IAPMO Z124
- ASTM E162
- ASTM E662



### KOHLER® Plastic Baths and Receptors Lifetime Limited Warranty

See website for detailed warranty information.

### Available Colors/Finishes

*Color tiles intended for reference only.*

Color	Code	Description
-------	------	-------------

	0	White
	96	Biscuit

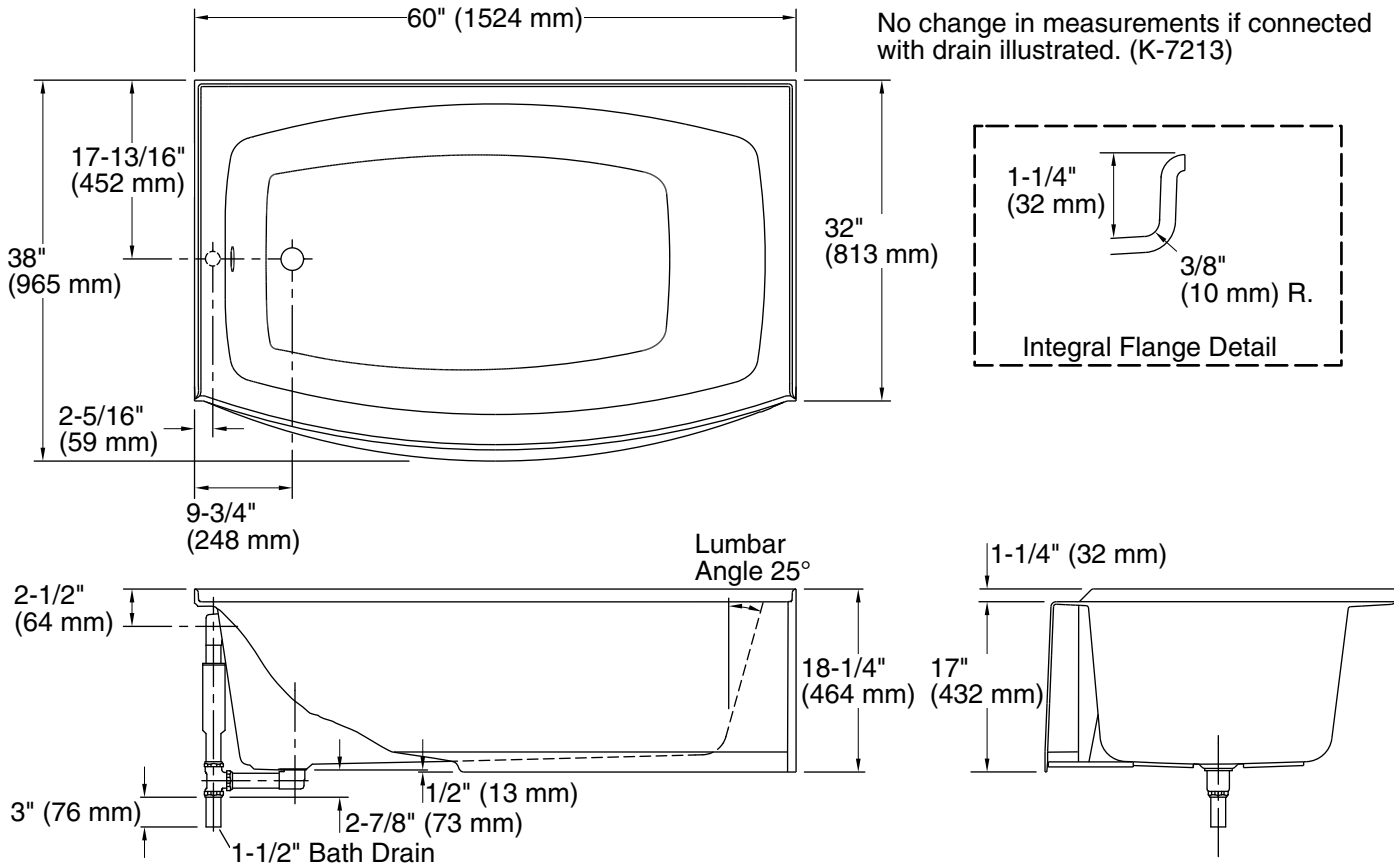

### Technical Information

All product dimensions are nominal.

Installation:	Three-wall alcove
Drain location:	Left
Basin area, bottom:	45-11/16" x 27-5/8" (1160 mm x 702 mm)
Basin area, top:	54" x 31" (1372 mm x 787 mm)
Weight:	78 lbs (35.4 kg)
Minimum floor load:	38 lbs/ft <sup>2</sup> (185.5 kg/m <sup>2</sup> )
Water depth:	12-5/8" (321 mm)
Water capacity:	60 gal (227.1 L)

### Notes

Measure your actual product for rough-in details.

Install this product according to the installation instructions.

The hot water supply should be 70% of the capacity of the bath or greater. Installations will vary.