

VARMILO

MIYA

VARMILO Keyboard artist.

User manual

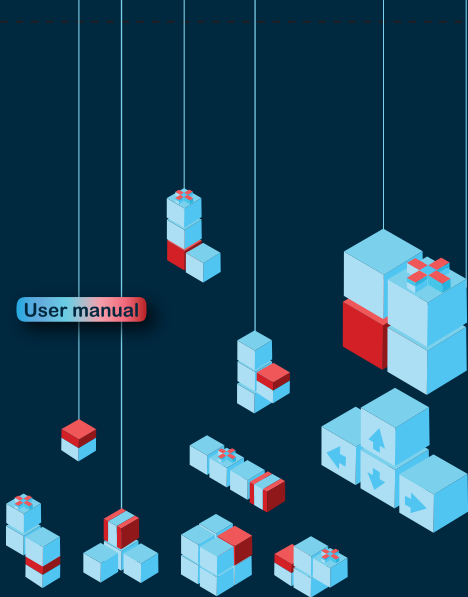

标准包装配件列表
Standard accessories list

数据线:
USB Cable:



拔键器:
Key Puller:

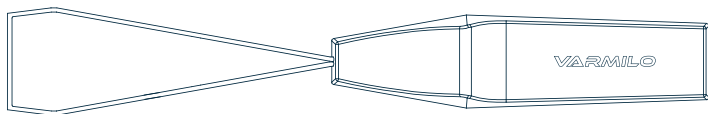

防尘罩:
Anti-dust Cover:

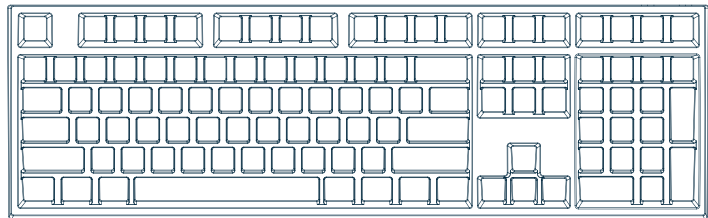

(在此仅列出108配列防尘罩，其他配列类同)
(Take MA108 layout as an example)



阿米洛静电电容机械轴触发方式

- 阿米洛静电电容轴在被按动时，电场感应极片之间的电容量会发生变化，键盘通过 $C=Q/U$ 公式计算电容量大小，达到一定电容量后触发。

阿米洛静电电容机械轴优点

- 无物理触点，理论寿命无限。
- 轴体手感一致性好，不会因为磨损而影响使用体验。
- 采用静电电容触发原理，同时又能保证纯粹的机械键盘手感。

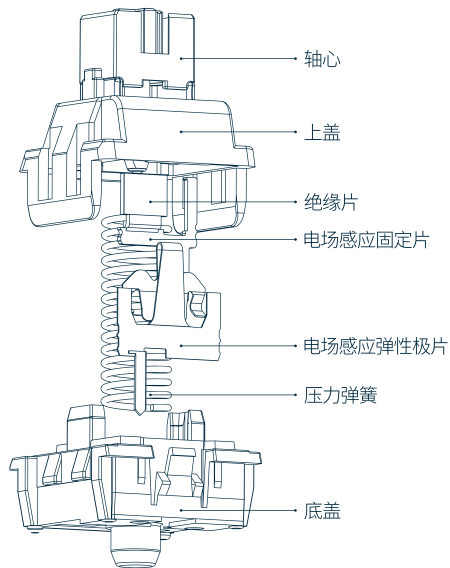

The Actuation of Varmilo EC switch

- When pressing Varmilo EC switch, the capacitance between field induction electrodes will change, the keyboard could calculate the capacitor volume through formula $C = Q / U$, and may trigger out when capacitance big enough.

Advantages of Varmilo EC switch

- No physical contact means no fatigue, theoretically speaking, it means unlimited service life.
- Longer consistency of the switch touch, better using experience.
- Adopting static capacitive triggering principle while ensuring pure mechanical keyboard feel.

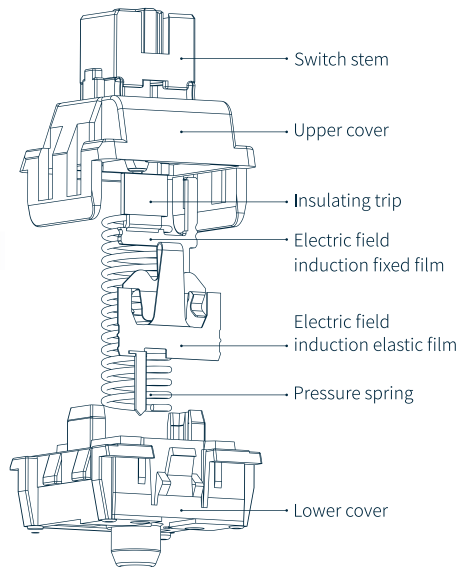

Esc、Fn功能 Esc、Fn Functions

	按键组合	功能
Esc功能	Shift+Esc	~
	Fn+Esc	`
Fn功能	Fn+数字行(1至=)	F行(F1至F12)
	Fn+F行(F1至F12)	数字行(1至=)
	Fn+J	Print Screen
	Fn+K	Scroll Lock
	Fn+L	Pause
	Fn+<	Home
	Fn+>	End
	Fn+Ctrl(右)	Application Key

	Key Combinations	Functions
Esc Functions	Shift + Esc	~
	Fn + Esc	`
Fn Functions	Fn + Number Line	F Line
	Fn + F Line	Number Line
	Fn + J	Print Screen
	Fn + K	Scroll Lock
	Fn + L	Pause
	Fn + <	Home
	Fn + >	End
	Fn + Ctrl(Right)	Application Key



- Fn+→可在常亮和呼吸两种模式中进行切换。
- Page Up、Page Down、Caps Lock不参与灯光效果。
- 在呼吸模式中按Fn+ ↓ 减缓灯效速度，Fn+ ↑ 加快灯效速度。
- 在常亮模式中按Fn+ ↓ 降低灯光亮度，Fn+ ↑ 提高灯光亮度。
- 上述功能仅对装有LED的键盘有效。
- Fn+X可关闭背光灯。

- Fn+→swapping between “full backlit” mode and “breathing” mode.
- Page Up、Page Down and Caps Lock do not operate in light effects.
- Under Breath, press Fn+ ↓ to slow down a light effect or Fn+ ↑ to speed it up.
- Under Always On, press Fn+ ↓ to decrease light brightness or Fn+ ↑ to increase it.
- The above functions are available only for the keyboards with LEDs.
- Turn off the backlit by Fn+X.



其他功能 Other Functions

- Fn+Page Down, 按一次, 数字行功能切换为F行功能(此时Page Down灯亮, Page Up灯灭)。
- Fn+Page Up, 按一次, F行功能切换为数字行功能(此时Page Up灯亮, Page Down灯灭)。
- Fn+任意Win, 按一次, 锁定或开启Win。
- Fn+左Win, 长按3秒, Caps Lock灯闪三下, Fn和左Win功能调换。
- Fn+左Ctrl, 长按3秒, Caps Lock灯闪三下, Caps Lock和左Ctrl功能调换。
- 关机断电及休眠后, 会自动记忆之前所有设定功能, 启动后自动回到设定的模式。
- To convert a number row to F function row, press Fn + Page Down.(The light of Page Down is on and that of Page Up off.)
- To covert F function row to a number row, press Fn + Page Up. (The light of Page Up is on and that of Page Down off.)
- To lock or switch on a Win key, press Fn and the Win simultaneously once.
- To exchange the functions of Fn and the left Win, hold the both down for 3 seconds until Caps Lock flashes three times.
- To exchange the functions of Caps Lock and the left Ctrl, hold the both down for 3 seconds until Caps Lock flashes three times.
- When the computer is restarted after shutdown or hibernation, previous keyboard settings will be resumed.



尊敬的用户，感谢您对Varmilo阿米洛的信任和支持。为了保护您的合法权益，更好的为您服务，我公司严格按照中华人民共和国相关法律，为您提供三包售后服务，产品保修说明如下：

1. 自您从授权经销商或官方途径购买Varmilo阿米洛产品之日起，若产品出现性能故障和品质问题，您将享有七天包退，十五天包换及一年免费保修服务。
2. 若您购买的产品，在超出上述保修期或产品因为人为原因损坏（自行拆卸，进水与烟灰，输入电流电压不当等）与自然灾害（如水灾，火灾，鼠害等）引起的损害，不在免费保修范围，您仍可享有Varmilo阿米洛提供的有偿维修服务，以使您的产品能够继续使用。
3. 消耗品（如脚垫、防滑贴）及赠品配件，不在三包的保修范围内。
4. 维修和更换之后的产品或配件，将延续送修之前所剩余的保修天数，或自Varmilo阿米洛将产品运送至您手上之日起90天。
5. 在您向Varmilo阿米洛提出维修和更换服务之前，请先参阅Varmilo阿米洛官网的产品疑难解答，网址为：Varmilo.com或致电Varmilo阿米洛售后服务电话：0755-26484009，若疑难解答无法帮您排除故障，您可将产品或配件交付至授权经销商或Varmilo阿米洛官方进行检测，我们会尽快为您提供相关服务。在将产品或配件送检之前，务必将非标准配件、定制配件提前取下，以免遗失或损坏。如：定制键帽，其他厂商的配件，私人LOGO等。
6. 本说明书的最终解释权 and 所有权属阿米洛品牌所有，后续产品升级请用户自行留意，持续关注，感谢您一路的支持与配合！

产品型号		产品号		出厂日期	
用户姓名		联系电话		购买日期	
用户地址					
问题描述：					



Warranty card

Dear users, thank you for great trust and support to Varmilo. In order to protect your legal rights and offer the best service, our company provides you with the after-sales service strictly in accordance with the laws of People's Republic of China, warranty terms are as follow:

1. Starting from the date you purchase Varmilo products from the authorized dealers or official channels, you will be entitled to 1-year free warranty service if the product has performance and quality problems.
2. The purchased product will be no longer under free warranty with the following conditions:
 - a: Exceed 1 year warranty period.
 - b: Damage caused by man-made (self-demolition, water splash, ash contamination, input current and voltage inappropriate)
 - c: Natural disasters (such as floods, fire, rodents) However, you will still be entitled to the paid maintenance service provided by Varmilo.
3. Consumables (such as the foot pad, anti-skid stickers, ect.) and gifts accessories are not under free warranty.
4. Products or accessories after repair or replacement will continue for the remaining of the warranty period, or 90 days starting from the date of receipt.
5. Please refer to the Varmilo Product Troubleshooting at <http://www.varmilo.com> or contact Varmilo sales representative before you request repair and replacement service. If the mentioned solutions can not solve your problem, you can deliver the product or accessory to an authorized dealer or Varmilo for testing. We will provide you with relevant services as soon as possible. Before submitting the product or accessories, please be sure to remove the non-standard parts and the customized parts in advance to avoid any loss or damage, such as: customized keycap, accessories from other manufactures, private logo and so on.
6. Varmilo reserves the right of final interpretation and ownership of this manual. Please pay close attention to subsequent product update. Thank you!

Model No.		Serial No.		Manufacturing Date	
Name		Tel.No.		Purchasing Date	
Add					
Problem Description:					





官网
Official Website



微博
Weibo



微信
WeChat

扫码即可了解有关阿米洛产品的最新信息
Scan the QR code for more detailed and updated news of Varmilo

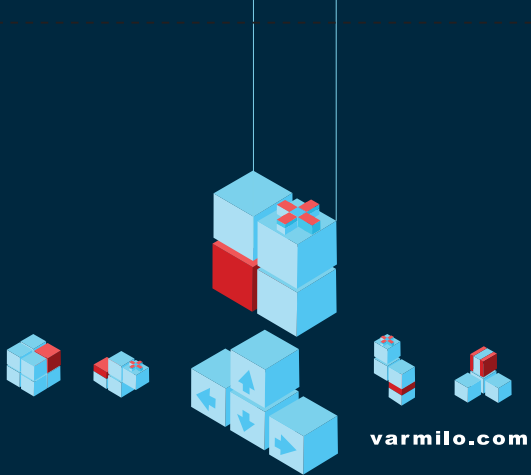

VARMILo