





# Assembly Instructions

## MODEL NO.: RC2 RECEPTION DESK

<b>A</b>  46Set	<b>B</b>  46Pcs	<b>C</b>  26Pcs	<b>D</b>  4Set	<b>E</b>  Ø80 2Pcs
--	--	--	--	--

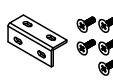
### STEP1

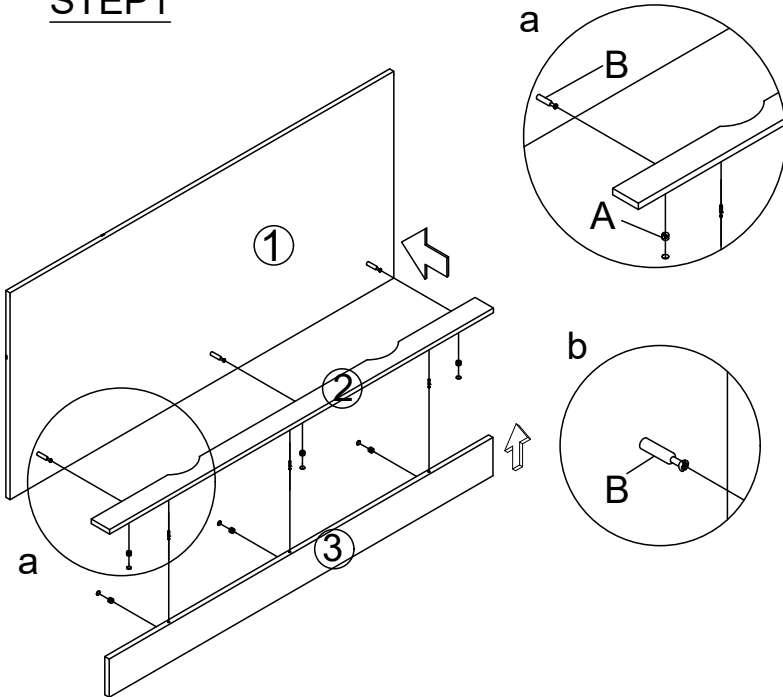

### STEP2

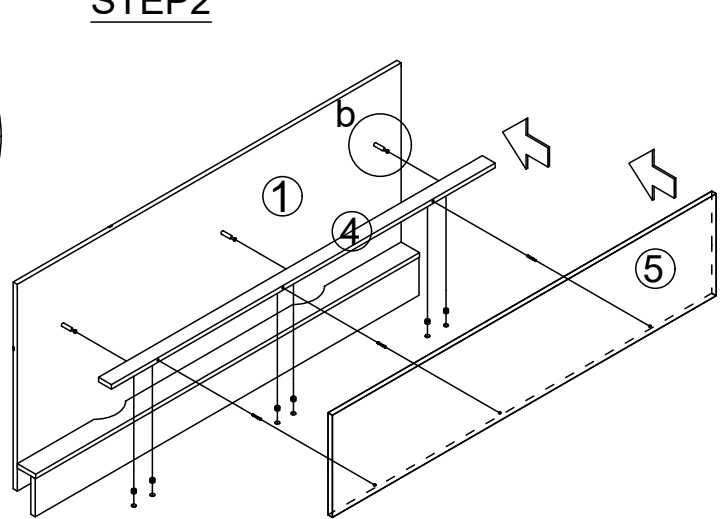

### STEP3

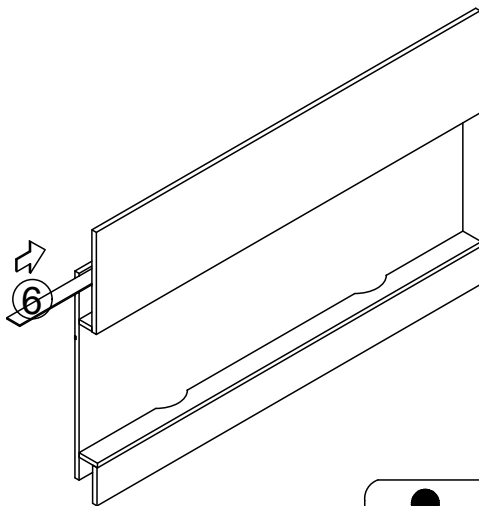

### STEP4

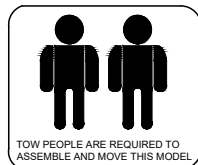
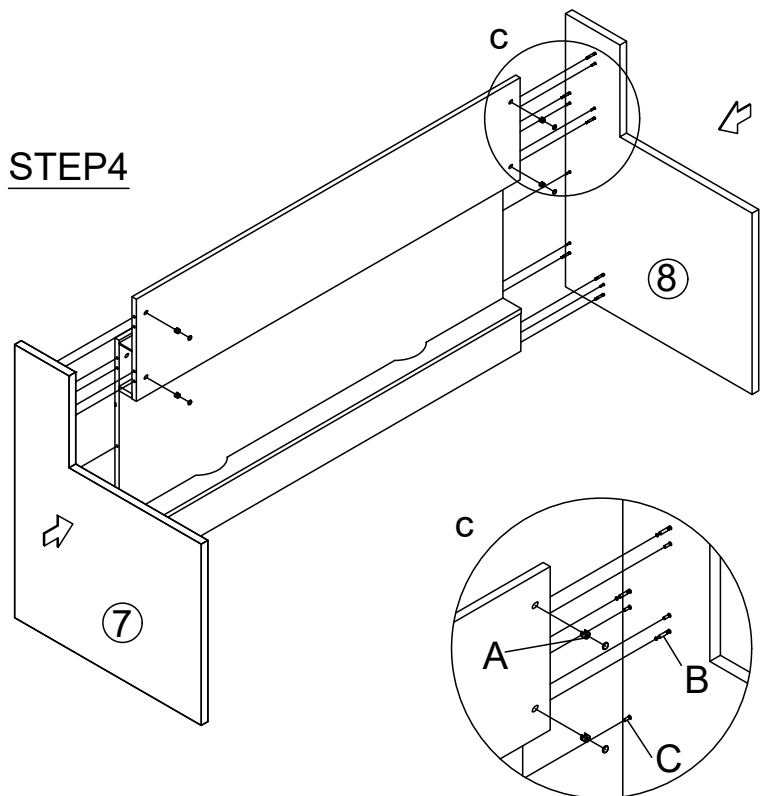

#### IMPORTANT NOTE:

- Place all parts on a clean and smooth surface such as a rug or carpet to avoid the parts from being scratched.
- Check to be sure that you have all parts and hardware.
- Remove all wrapping materials, including staples & packing straps before you start to assemble.
- Don't tighten all screws/bolts until all completely assembled.
- Keep all hardware parts out of reach of children

# Assembly Instructions

## MODEL NO.: RC2 RECEPTION DESK

### STEP 5

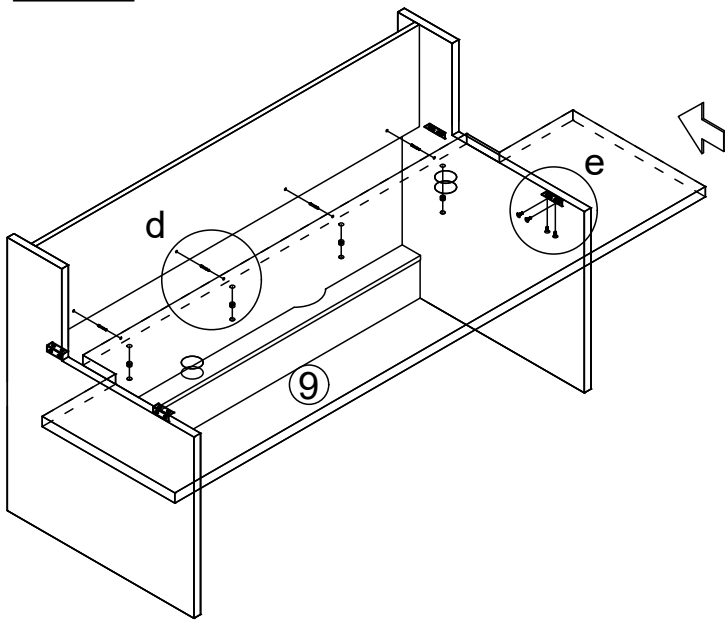

### STEP 6

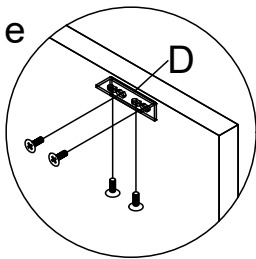
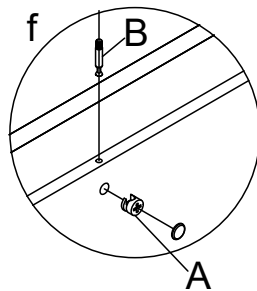
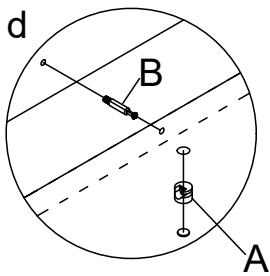
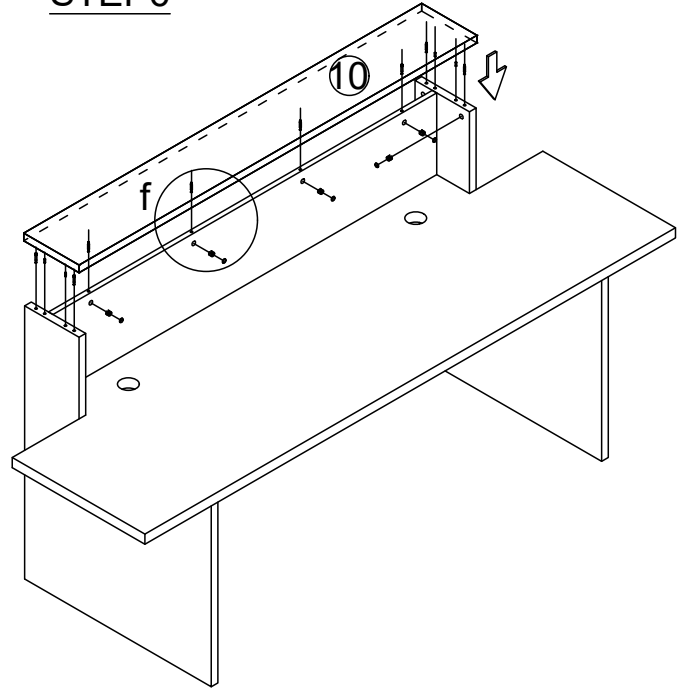

### COMPLETED ASSEMBLY

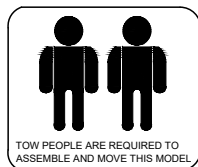
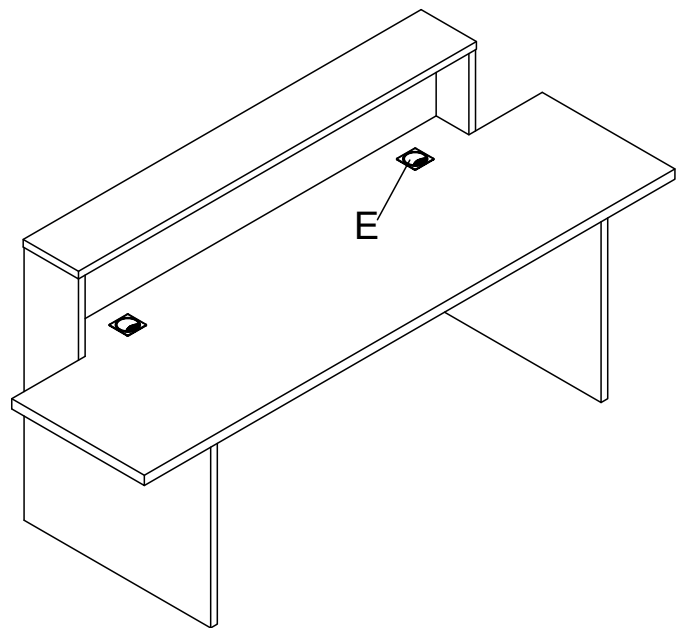

#### IMPORTANT NOTE:

- Place all parts on a clean and smooth surface such as a rug or carpet to avoid the parts from being scratched.
- Check to be sure that you have all parts and hardware.
- Remove all wrapping materials, including staples & packing straps before you start to assemble.
- Don't tighten all screws/bolts until all completely assembled.
- Keep all hardware parts out of reach of children