

DTR Series



BRASS TRICOCK VALVE



Specifications

- 250 lbs. WSP @ 406° F Max.
- 400 lbs. WOG
- MNPT Threaded End
- Sizes: 1/2"

Features

- Brass Body
- Steel Hand Wheel
- 100% Leak & Pressure Tested

Item	Size	Shank	A	B	Weight
DTR-L	1/2"	Long	4.06"	1.06"	0.48 lbs
DTR-S	1/2"	Short	3.62"	1.06"	0.45 lbs

Ref#	Description
1	Brass Body
2	Nozzle
3	Packing
4	Brass Packing
5	Washer
6	Stem
7	Steel Hand Wheel
8	Screw

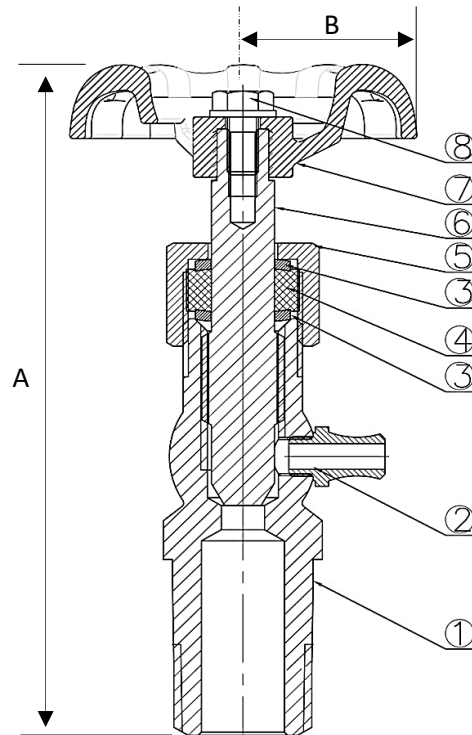

Copyright©2021 Höt-Steam® All rights reserved.

Ver.2211