

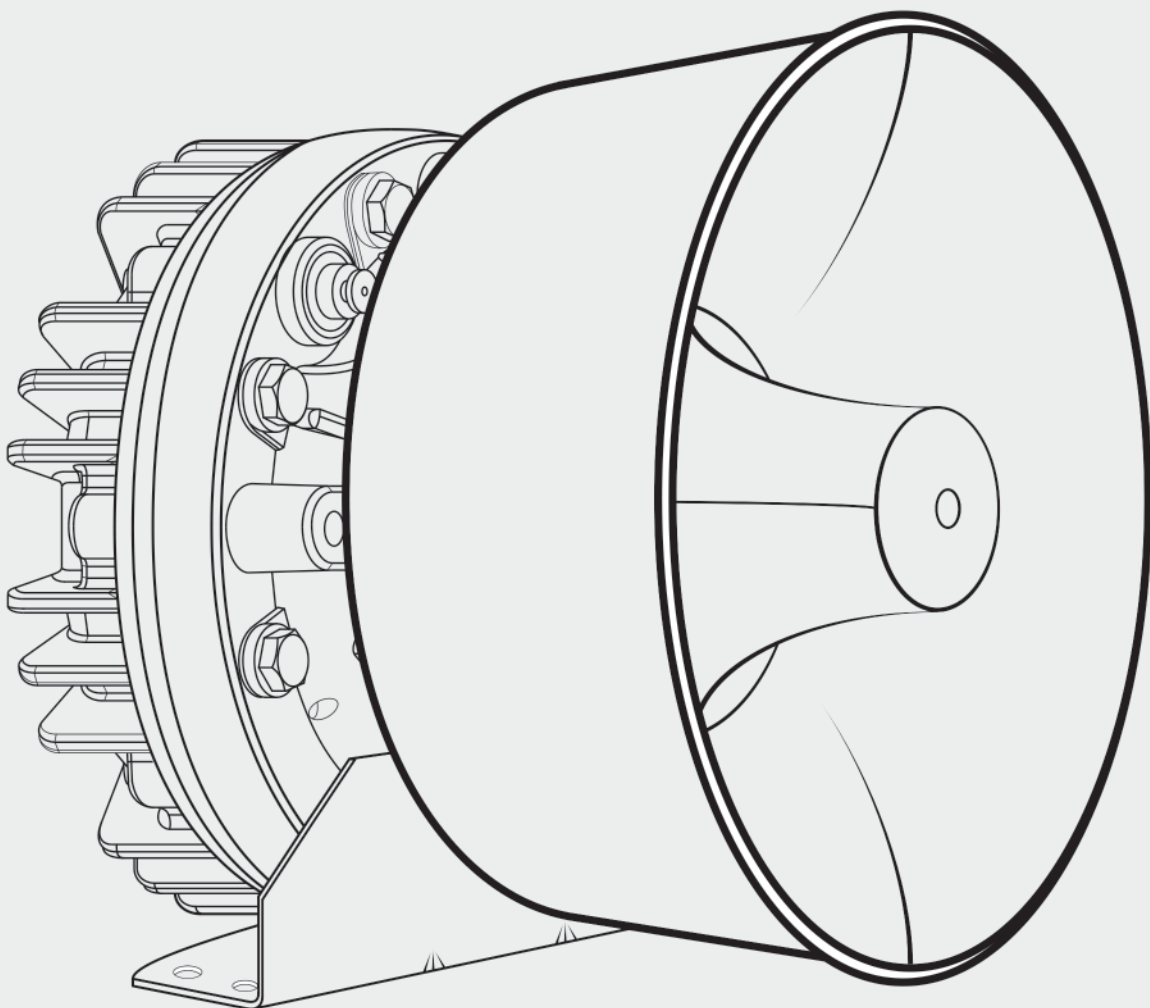

ABRAMS INSTRUCTION MANUAL
WWW.ABRAMSMFG.COM

INSTALLATION AND CONFIGURATION MANUAL
ABRAMS SUPREME 200W SIREN SPEAKER

V.1.3



SUPREME 200W SIREN SPEAKER

IMPORTANT! PLEASE READ THROUGH ALL PROVIDED INSTRUCTIONS AND ANY LISTED WARNINGS IN REGARDS TO PRODUCT USE.

MODEL#: SPS-200

INSTALLATION AND CONFIGURATION MANUAL
ABRAMS SUPREME 200W SIREN SPEAKER

Table of Contents:

SAFETY REGULATIONS AND WARRANTY.....2

EQUIPMENT AND DIMENSIONS..... 3

WIRING AND FUNCTION..... 4

INSTALLING BRACKETS..... 5

TROUBLESHOOTING AND MAINTENANCE..... 6

WARNING:

FAILURE TO INSTALL OR USE THIS PRODUCT ACCORDING TO MANUFACTURER’S RECOMMENDATIONS MAY RESULT IN PROPERTY DAMAGE, SERIOUS INJURY, AND/OR DEATH.

IMPORTANT:

PLEASE READ ALL OF THE FOLLOWING INSTRUCTIONS BEFORE INSTALLING YOUR NEW ABRAMS PRODUCT.

- PROPER INSTALLATION OF THIS PRODUCT REQUIRES THE INSTALLER TO HAVE A GOOD UNDERSTANDING OF AUTOMOTIVE ELECTRONICS, SYSTEMS AND PROCEDURES.
- DO NOT INSTALL THIS PRODUCT OR ROUTE ANY WIRES IN THE DEPLOYMENT AREA OF YOUR AIR BAG. EQUIPMENT MOUNTED OR LOCATED IN THE AIR BAG DEPLOYMENT AREA WILL DAMAGE OR REDUCE THE EFFECTIVENESS OF THE AIR BAG, OR BECOME A PROJECTILE THAT COULD CAUSE SERIOUS PERSONAL INJURY OR DEATH. REFER TO YOUR VEHICLE OWNER MANUAL FOR THE AIR BAG DEPLOYMENT AREA. THE USER/INSTALLER ASSUMES FULL RESPONSIBILITY TO DETERMINE PROPER MOUNTING LOCATION, BASED ON PROVIDING ULTIMATE SAFETY TO ALL PASSENGERS INSIDE THE VEHICLE.
- IF MOUNTING THIS PRODUCT REQUIRES DRILLING HOLES, THE INSTALLER MUST BE SURE THAT NO VEHICLE COMPONENTS OR OTHER VITAL PARTS COULD BE DAMAGED BY THE DRILLING PROCESS. CHECK BOTH SIDES OF THE MOUNTING SURFACE BEFORE DRILLING BEGINS. ALSO DE-BURR ANY HOLES AND REMOVE ANY METAL SHARDS OR REMNANTS. INSTALL GROMMETS INTO ALL WIRE PASSAGE HOLES.
- INSPECT AND OPERATE THIS PRODUCT REGULARLY TO CONFIRM ITS PROPER OPERATION AND MOUNTING CONDITION. DO NOT USE A PRESSURE WASHER TO CLEAN THIS PRODUCT.
- FOR THIS PRODUCT TO OPERATE AT OPTIMUM EFFICIENCY, A GOOD ELECTRICAL CONNECTION TO CHASSIS GROUND MUST BE MADE. THE RECOMMENDED PROCEDURE REQUIRES THE PRODUCT GROUND WIRE TO BE CONNECTED DIRECTLY TO THE NEGATIVE (-) BATTERY POST.
- IT IS RECOMMENDED THAT THESE INSTRUCTIONS BE STORED IN A SAFE PLACE AND REFERRED TO WHEN PERFORMING MAINTENANCE AND/OR REINSTALLATION OF THIS PRODUCT.
- FAILURE TO FOLLOW THESE SAFETY PRECAUTIONS AND INSTRUCTIONS COULD RESULT IN DAMAGE TO THE PRODUCT OR VEHICLE AND/OR SERIOUS INJURY TO YOU AND YOUR PASSENGERS!
- IF THIS PRODUCT USES A REMOTE DEVICE TO ACTIVATE OR CONTROL THIS PRODUCT, MAKE SURE THAT THIS CONTROL IS LOCATED IN AN AREA THAT ALLOWS BOTH THE VEHICLE AND THE CONTROL TO BE OPERATED SAFELY IN ANY DRIVING CONDITION.
- DO NOT ATTEMPT TO ACTIVATE OR CONTROL THIS DEVICE IN A HAZARDOUS DRIVING SITUATION.

WARRANTY (5 YEAR WARRANTY)

THIS PRODUCT WAS TESTED AND FOUND TO BE OPERATIONAL AT THE TIME OF MANUFACTURE. PROVIDED THIS PRODUCT IS INSTALLED AND OPERATED IN ACCORDANCE WITH THE MANUFACTURER’S RECOMMENDATIONS, ABRAMS GUARANTEES THIS PRODUCT FOR A PERIOD OF 5 YEARS FROM THE DAY OF PURCHASE OR DELIVERY, WHICH EVER IS LATER. UNITS DEMONSTRATED TO BE DEFECTIVE WITHIN THE WARRANTY PERIOD WILL BE REPLACED. IMPROPER INSTALLATION OR USE OF INAPPROPRIATE OR INADEQUATE WIRING OR CIRCUIT PROTECTION CAUSES THE WARRANTY TO BE VOID. FAILURE OR DESTRUCTION OF THE PRODUCT RESULTING FROM ABUSE OR UNUSUAL USE AND/OR ACCIDENTS IS NOT COVERED BY THIS WARRANTY. ABRAMS SHALL IN NO WAY BE LIABLE FOR OTHER DAMAGES INCLUDING CONSEQUENTIAL, INDIRECT OR SPECIAL DAMAGES WHETHER LOSS IS DUE TO NEGLIGENCE OR BREACH OF WARRANTY. ABRAMS MAKES NO OTHER EXPRESS OR IMPLIED WARRANTY INCLUDING, WITHOUT LIMITATION, WARRANTIES OF FITNESS OR MERCHANTABILITY, WITH RESPECT TO THIS PRODUCT.



INSTALLATION AND CONFIGURATION MANUAL ABRAMS SUPREME 200W SIREN SPEAKER

EQUIPMENT AND DIMENSIONS

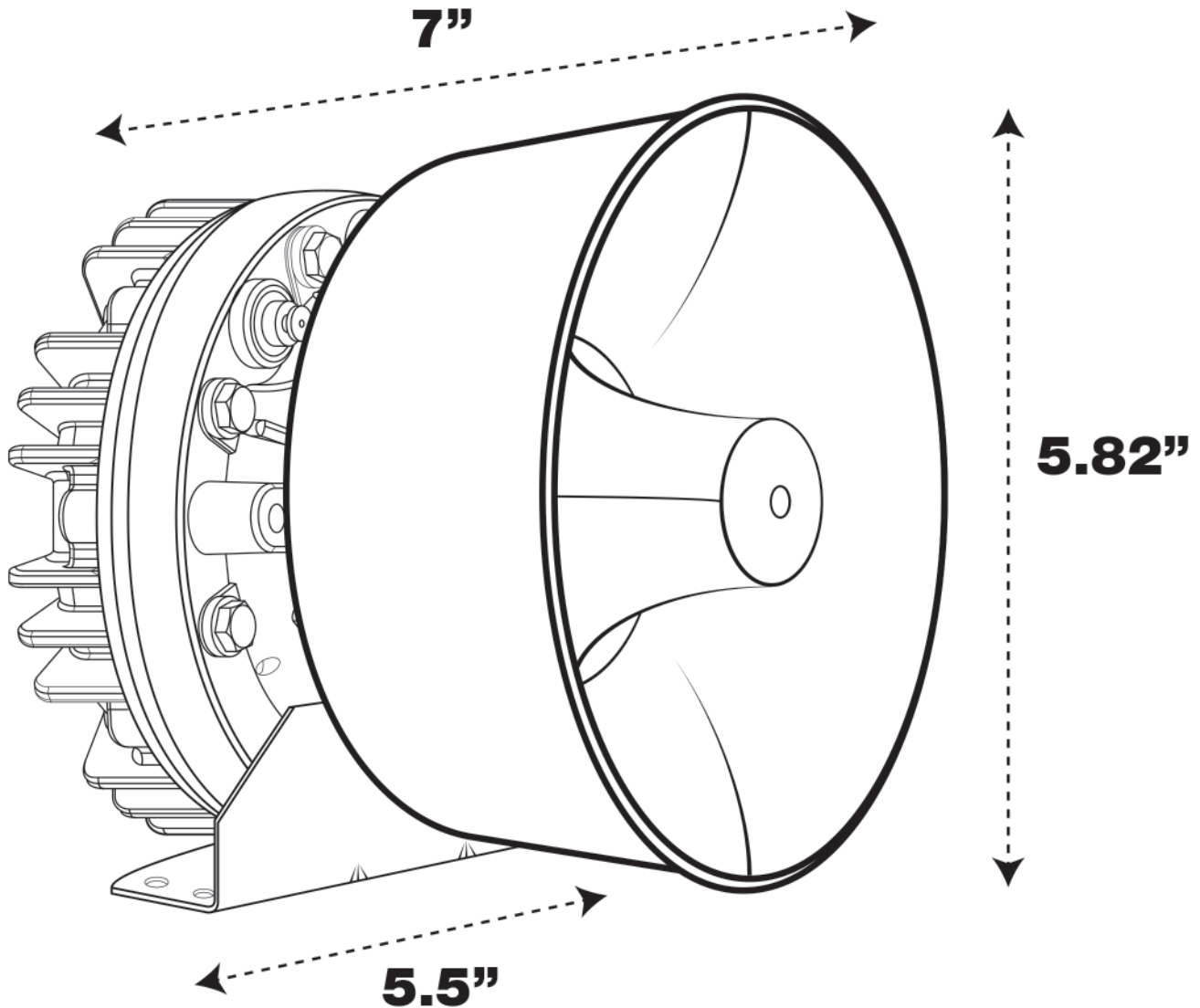

PACKAGE CONTENTS:

- ABRAMS SUPREME 200W SIREN SPEAKER
- UNIVERSAL L-BRACKET
- 6FT SPEAKER CABLE HARNESS
- PRODUCT INSTALLATION MANUAL

IMPORTANT! PLEASE READ THROUGH ALL PROVIDED INSTRUCTIONS AND ANY LISTED WARNINGS IN REGARDS TO PRODUCT USE.

INSTALLATION AND CONFIGURATION MANUAL ABRAMS SUPREME 200W SIREN SPEAKER

WIRING AND FUNCTION

STEP 1:
 THE ABRAMS SUPREME 200W SPEAKERS DOES NOT INCLUDE A SIREN UNIT. TO ACTIVATE THE SPEAKER, FOLLOW OEM INSTRUCTIONS FOR INSTALLING THE SIREN SYSTEM UNIT.

IMPORTANT! THE ABRAMS SUPREME 200W SIREN SPEAKER DOES NOT HAVE A POSITIVE OR NEGATIVE SPEAKER OUTPUT WIRE

STEP 2:
 TO POWER THE SPEAKER, EXTEND BOTH BROWN WIRES TO THE OUTPUT TERMINAL OF THE SIREN SYSTEM AMPLIFIER. FOLLOW SIREN OEM INSTRUCTIONS TO CORRECTLY CONNECT THE SPEAKER UNIT TO THE SIREN SPEAKER SYSTEM.

THE ABRAMS SUPREME 200W SPEAKER DOES NOT HAVE A POSITIVE OR GROUND WIRE.

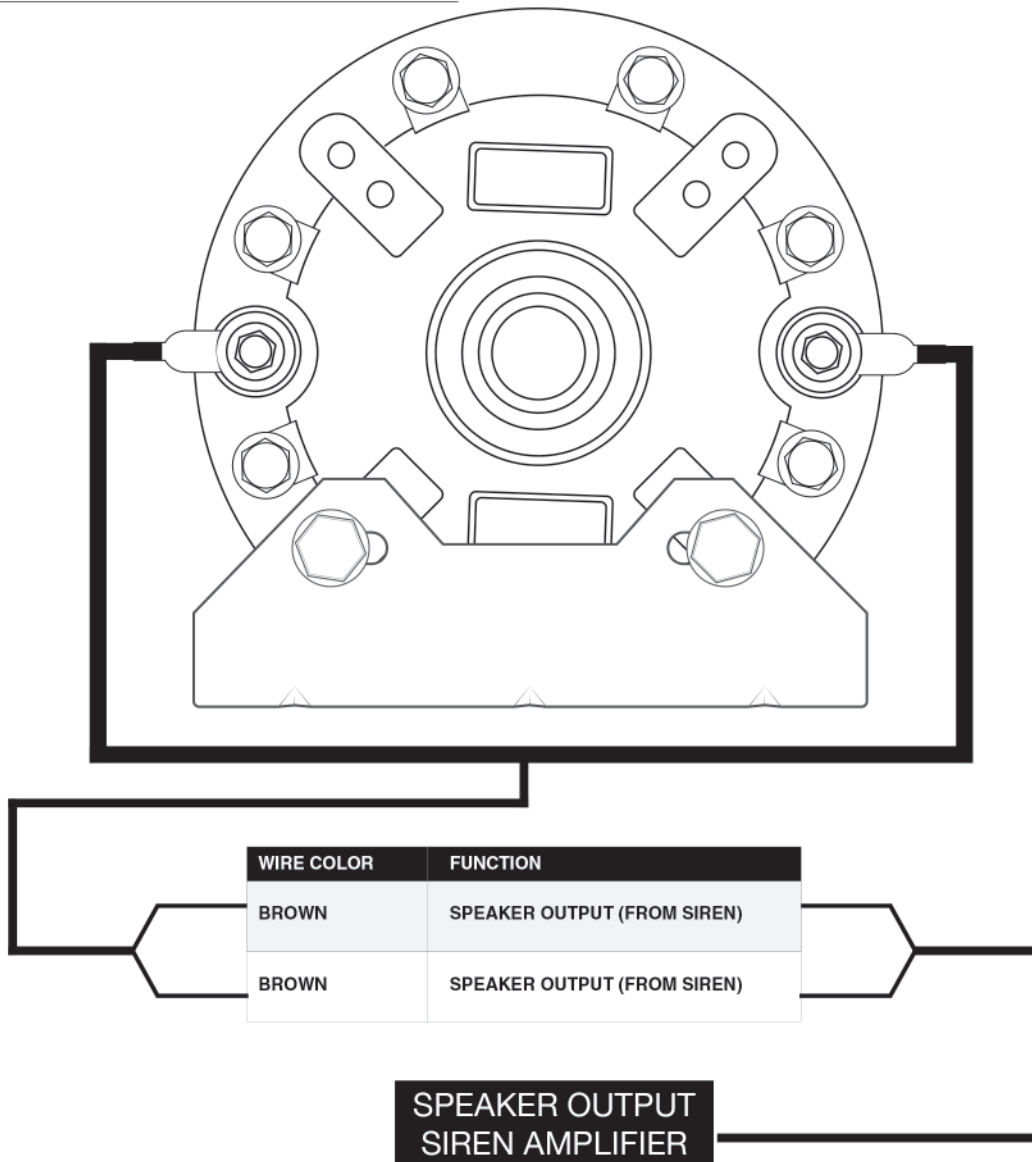

IMPORTANT:
 THE INSTALLATION TECHNICIAN AND OPERATOR MUST READ THIS MANUAL BEFORE STARTING INSTALLATION OR OPERATION OF YOUR NEW PRODUCT. THEY MUST HAVE A THOROUGH UNDERSTANDING OF AUTOMOTIVE SYSTEMS, ELECTRONICS AND PROCEDURES.

WARNING:
 PLEASE UNDERSTAND THAT THE USER AND INSTALLER ASSUME ULTIMATE, COMPLETE AND FULL RESPONSIBILITY IN DETERMINING PROPER MOUNTING LOCATION AND POSITIONING. WHEN INSTALLING, CONSIDER A LOCATION BASED ON ITS ABILITY TO PROVIDE TOTAL SAFETY TO ALL PASSENGERS.

INSTALLATION AND CONFIGURATION MANUAL ABRAMS SUPREME 200W SIREN SPEAKER

INSTALLING BRACKETS

INSTRUCTIONS FOR MOUNTING A L-BRACKET

STEP 1:
CLEAN THE SELECTED MOUNTING SURFACE AREA.

STEP 2:
WITH THE SPEAKER UNIT RESTED ON A WORK SURFACE, REMOVE THE HORN FROM THE SPEAKER BY TURNING THE FOLDED KNOB COUNTER-CLOCKWISE

STEP 3:
REMOVE THE TWO BOLTS CONNECTING THE SPEAKER TO THE PROVIDED L-SHAPED BRACKET. THIS WILL DETACH THE SPEAKER FROM THE BRACKET.

STEP 4:
PLACE THE L-BRACKET AGAINST THE SELECTED MOUNTING SURFACE, AND MARK THE SPOT FOR AT LEAST TWO MOUNTING HOLES.

STEP 5:
DRILL A MINIMUM OF TWO, 1/4" HOLES IN THE MOUNTING SURFACE, MAKING SURE NOT TO DAMAGE ANY VITAL COMPONENTS OF THE MOUNTING SURFACE.

STEP 6:
PROCEED TO SECURE THE PROVIDED BRACKET TO THE MOUNTING SURFACE. BOLT THE L-BRACKET TO THE SURFACE MOUNT, UTILIZING BOLTS LARGER THAN 1/4" TO SECURE THE L-BRACKET TO THE SURFACE MOUNT.

STEP 7:
MOUNT THE SPEAKER BACK ON TO THE L-BRACKET.

STEP 8: REPOSITION HORN OVER SPEAKER BY TURNING THE FOLDED KNOB CLOCKWISE.

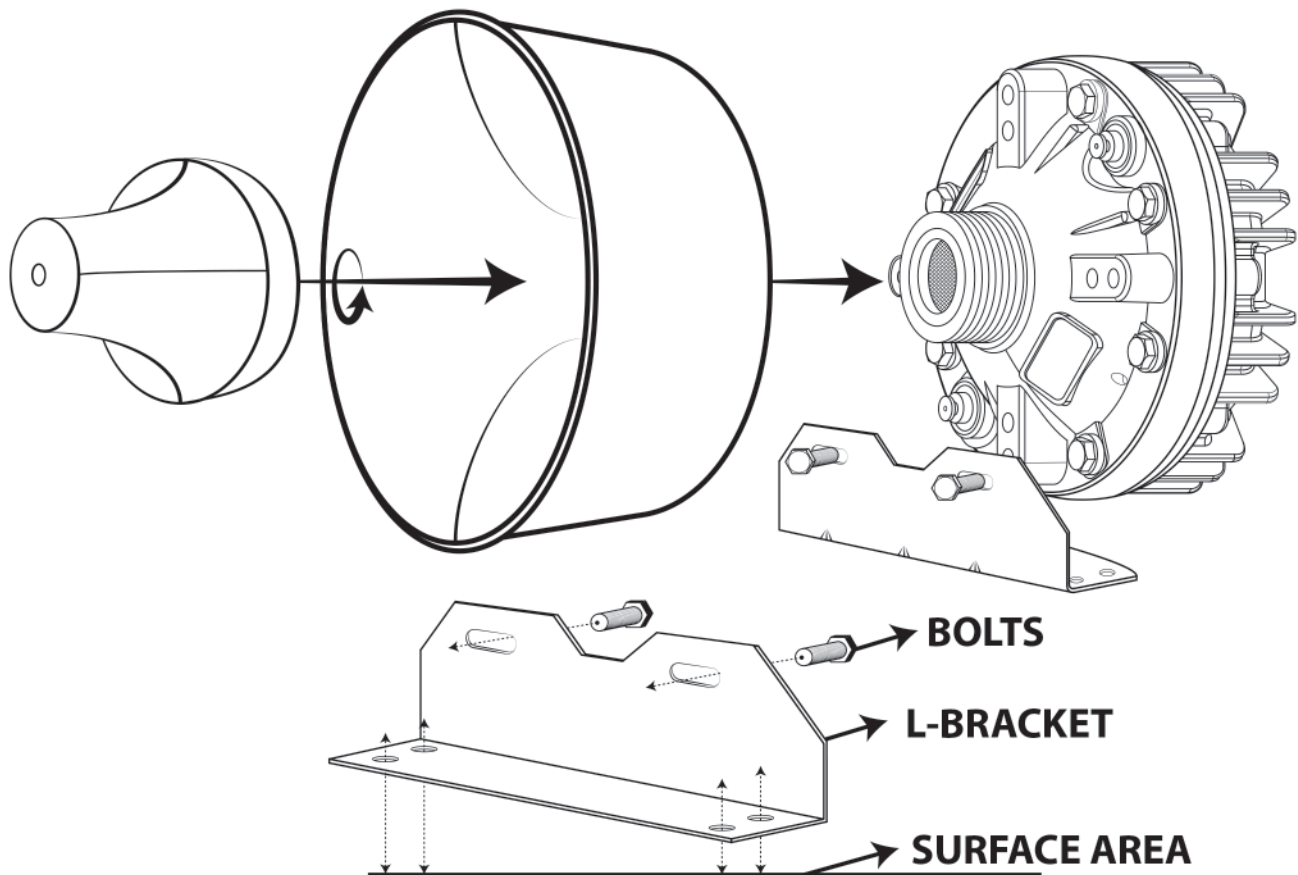

UTILIZING BOLTS LARGER THAN 0.25", SECURE THE L-BRACKET TO THE SURFACE MOUNT.

**IF YOU REQUIRE ADDITIONAL INFORMATION AND/OR VIDEO AND USER GUIDES, PLEASE VISIT WWW.ABRAMSMFG.COM/SUPPORT OR CALL ABRAMS CUSTOMER SUPPORT 844.9.ABRAMS

INSTALLATION AND CONFIGURATION MANUAL ABRAMS SUPREME 200W SIREN SPEAKER

TROUBLESHOOTING AND MAINTENANCE

Trouble Shooting

All manufacture defects are covered under the Abrams Warranty accordingly. Warranty is void with disassembly or rewiring of any Abrams Products or Improper Wiring or Installation. If you are unsure how to trouble shoot your siren speaker for any reason or if the trouble shooting does not fix your issue, call Customer Service immediately for assistance at 844-9-ABRAMS

Problem	Scenarios	Possible Cause	Trouble Shooting
Static	Muffled or Crackling Sound	Electrical interference OR Bad amplifier Improper Ground	<p>Check the ground cable to ensure that the siren is grounded correctly and its cables have no nicks or cuts in the wiring cause electrical interference from the chassis.</p> <p>Disconnect the speaker and test the amplifier, the tones can be heard faintly from the amplifier and if there is static heard from the amplifier the amplifier will need to come in for service. Move the ground to the battery terminal. If already grounded correctly, check how the siren amplifier is secured to the vehicle. If the screws securing the amplifier can cause electrical interference if screwed the floor of the vehicle where metal is contacting the amplifier.</p> <p>If test are inconclusive, submit a RMA online at www.abramsmfg.com/form/create_rma/ contact our customer service department email info@abramsmfg.com to place a warranty claim.</p> <p>Test another speaker to compare sound, if another speaker is working with no static, submit a RMA online at www.abramsmfg.com/form/create_rma/ contact our customer service department email info@abramsmfg.com to place a warranty claim.</p>
No Sound	Siren is powered on but no sound from speaker.	The siren may be blown or have a short	Test another speaker to compare sound, if another speaker is working with no issues, submit a RMA online at www.abramsmfg.com/form/create_rma/ contact our customer service department email info@abramsmfg.com to place a warranty claim.