



LGS-2200-H

Abrams Logic 2200 Programmable Handheld Siren System & Light Controller

— Installation & Operation Manual —

Firmware Ver. A1



NOTICE TO INSTALLER

Before installation and operation — read all instructions and warnings.
Deliver this manual to the end user of this product.

TABLE OF CONTENTS

WARNING	1
CONTENTS	2
SPECIFICATIONS	2
WIRING	3
DEFAULT HAND-CONTROLLER OPERATION	6
PC PROGRAMMING	8
INSTALLATION	9

WARNING

1. Proper installation of the product requires the installer to have a good understanding of automotive electronics, systems and procedures. It is essential to install the unit properly to ensure safe and reliable operation.
2. Please read through all instructions thoroughly and carefully before installing the unit.
3. Failure to follow these instructions could result in serious damage to the unit or vehicle and may void warranties.
4. The correct mounting and wiring is the key to the effectiveness of **LGS-2200-H**
5. Installers must read and follow instructions and warnings in the manual from the original manufacturer.
6. The operator should verify the siren system is fastened to the vehicle securely and is functioning properly. Failure to follow all safety precautions and instructions may cause property damage, injury, or death.
7. Ensure that any switch control panel is located in an area that allows both the vehicle and the control panel to be operated safely in any driving condition.

WARNING

Sound Hazard - Sound level from a siren speaker (109dB at 2M) may cause hearing damage.



Do not operate the siren without adequate hearing protection for you and anyone in immediate vicinity.
(Ref. OSHA 1910.95 for occupational noise exposure guidelines)

CONTENTS

- ❶ Siren amplifier x 1 pc
- ❷ 4-PIN power harness x 1 pc
- ❸ 4-PIN high current relay outputs harness x 1 pc
- ❹ 4-PIN speaker harness x 1 pc
- ❺ 8-PIN inputs harness x 1 pc
- ❻ 10-PIN mid/low current relay outputs harness x 1 pc
- ❼ Sheet metal screws (ø4 x 16mm) x 4 pcs
- ❽ Controller x 1 pc
- ❾ Controller clip x 1 pc
- ❿ Sheet metal screws (ø4 x 16mm) x 2 pcs
- ⓫ Decal x 1 set
- ⓬ Manual x 1 pc

Accessories

- ❶ RJ45 cable x 1 pc (6m)
- ❷ RJ45 coupler x 1 pc

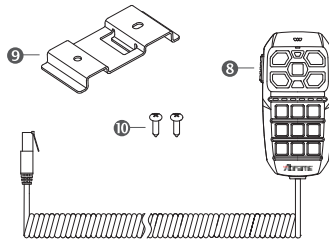
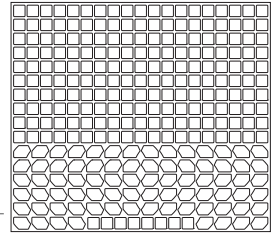
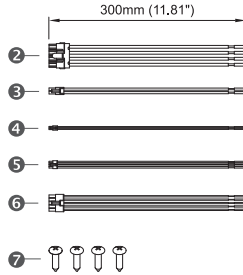
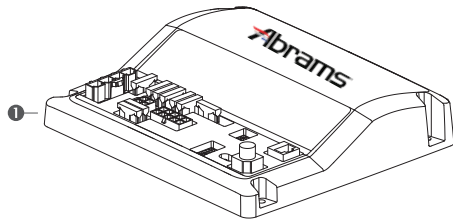
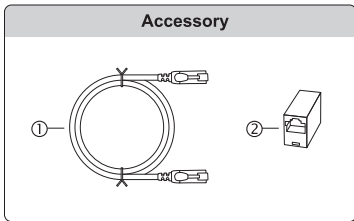

SPECIFICATIONS

Input Voltage: 12~24VDC

Siren Output Power: 200W (100W x2)

Siren Output Load: 100W-ACR 11Ω

Siren Frequency: 759Hz - 1592Hz (may varies through PC setting)

Max. Current (Siren only):

20A @ 12VDC / 10A @ 24VDC (w/o light control outputs)

Standby Current: 0 mA (w/o IGN wire) / <0.35 A (w/ IGN wire)

Operating Temperature Range: -30°C~65°C

Light Controls Output: 15A x3, 10A x3, 2A x2, 0.25A x4

Fuse Rating:

Blade Fuse: 30A x1, 15A x3, 10A x3, 2A x2

Resettable Fuse: 0.25A x4

Dimensions(amplifier): 190mm x 217mm x 45.6mm

Dimensions(controller): 66.4mm x 134mm x 26.9mm

TONES	CYCLE RATES
HORN	Composite (Constant)
WAIL	12CPM
YELP	155CPM
PHASER (PIERCER)	882CPM
HI/LO	40CPM

(Actual Tone may varies through PC setting)

WIRING

• Wiring diagram:

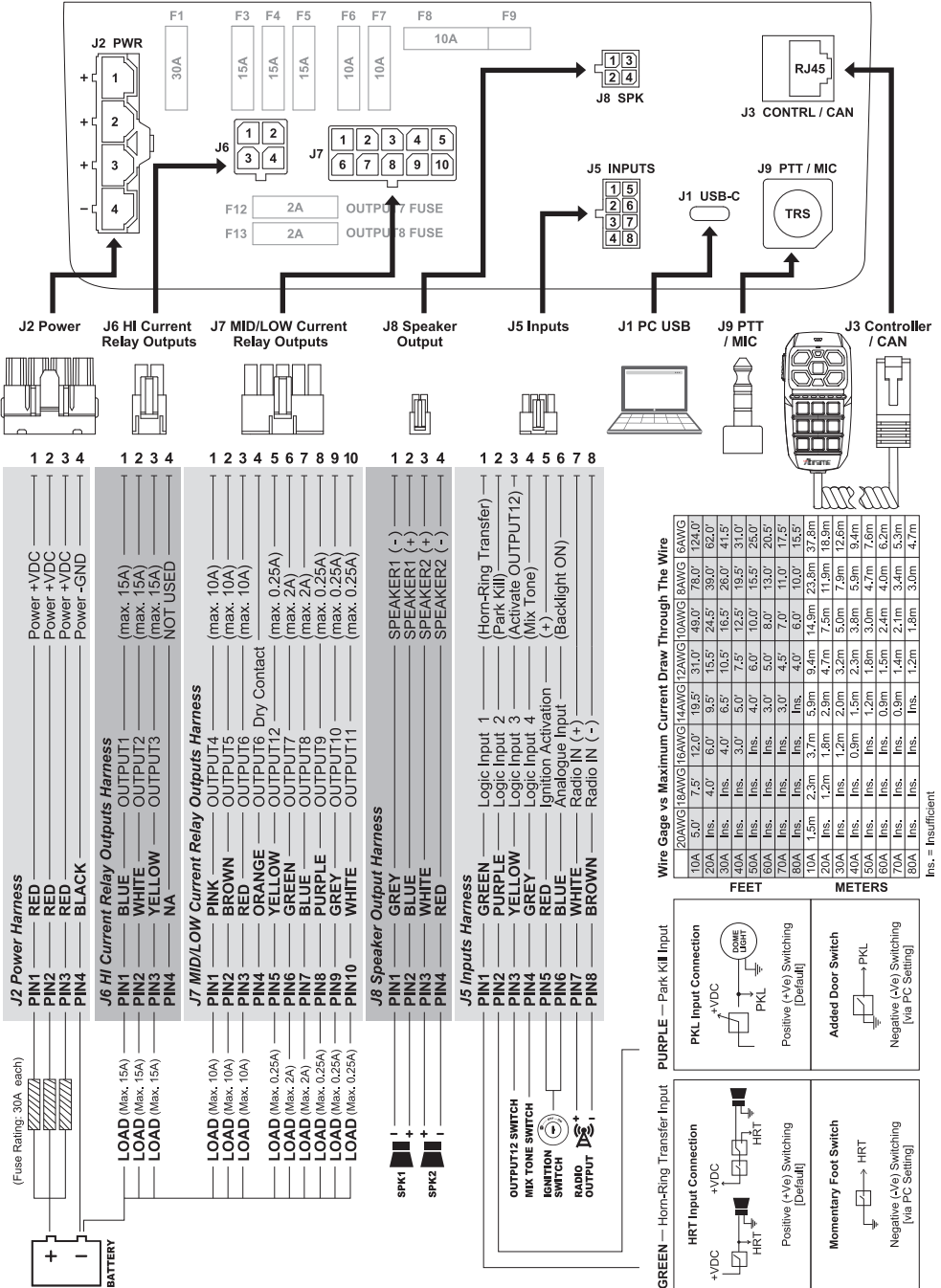

Wire Gauge vs Maximum Current Draw Through The Wire

Wire	20AWG (16AWG)	14AWG (12AWG)	10AWG (8AWG)	6AWG
10A	5.0' 7.5'	12.0' 19.5'	31.0' 49.0'	78.0' 124.0'
20A	Ins.	4.0' 9.5'	15.5' 24.5'	39.0' 62.0'
30A	Ins.	4.0' 6.5'	10.5' 16.5'	26.0' 41.5'
40A	Ins.	3.0' 5.0'	7.5' 12.5'	19.5' 31.0'
50A	Ins.	Ins.	4.0' 6.0'	10.0' 15.5'
60A	Ins.	Ins.	3.0' 5.0'	8.0' 13.0'
70A	Ins.	Ins.	3.0' 4.5'	7.0' 11.0'
80A	Ins.	Ins.	Ins.	4.0' 10.0'
100A	1.5m	2.3m	3.7m	5.9m
20A	1.2m	2.0m	3.2m	5.0m
30A	Ins.	1.2m	2.0m	3.2m
40A	Ins.	0.9m	1.5m	2.3m
50A	Ins.	0.9m	1.2m	1.8m
60A	Ins.	Ins.	1.0m	1.5m
70A	Ins.	Ins.	0.9m	1.2m
80A	Ins.	Ins.	Ins.	1.2m

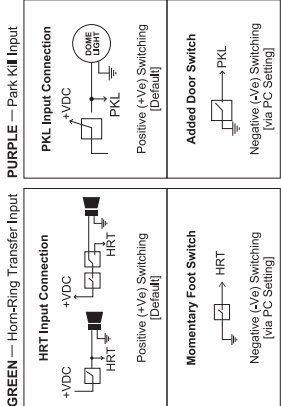

Ins. = Insufficient

4-PIN POWER Harness (J2 Connector)

● **Power +VDC & -GND (J2-PIN1~PIN3 & J2-PIN4)**

1. Connect three **RED** wires to the positive (+) battery terminal. Fuse each wire independently @30 Amps (user-supplied). DO NOT install these fuses until the wiring for the entire system has been completed.
2. Connect **BLACK** wire to the vehicle's chassis ground (typically adjacent to the battery).
3. Plug the Connector into the siren amplifier unit.

4-PIN SPEAKER Harness (J8 Connector)

● **Speaker 1 Out (J8-PIN1~PIN2)**

Connect the **GREY** (SPK1-) and **BLUE** (SPK1+) wires to one 100W 11-ohm impedance speaker.

● **Speaker 2 Out (J8-PIN3~PIN4)**

Connect the **WHITE** (SPK2+) and **RED** (SPK2-) wires to one 100W 11-ohm impedance speaker.

NOTE: Do not attempt to connect two speakers in parallel or series on any one pair of Speaker outlets.

8-PIN INPUTS Harness (J5 Connector)

● **Ignition Input (J5-PIN5)**

Apply +VDC continuously to **RED** wire to enable the siren system. This wire serves as the power switch for the entire unit. Connect this wire to a positive circuit controlled by the vehicle ignition switch, with the ignition acting as the ON/OFF switch (power up /power down). DO NOT connect this wire directly to the battery, the system will not operate and the battery will drain.

● **Programmable Logic Inputs (J5-PIN1~PIN4)**

These four inputs may be programmed to activate other Button, Input, Output, Siren and/or etc. via positive or negative switching. By default, they function as Horn-Ring, Park Kill and Mix Tone inputs:

- **Horn-Ring Transfer Input (J5-PIN1)**

Connect this input to the vehicle horn ring circuit; apply +VDC continuously to **GREEN** wire for Air Horn Tone. This tone will temporarily override all other Siren Tones and Radio Rebroadcast while it is activated. If Hands-Free mode is active, momentarily apply +VDC to start the Siren, tap again to change tone and double tap to end the Siren. This input also activate OUTPUT7 while it is active.

- **Park Kill Input (J5-PIN2)**

Connect this input to the vehicle Park Shift circuit; apply +VDC continuously to **PURPLE** wire for temporarily mute of all other Siren Tones and Radio Rebroadcast while it is activated. Once released, all siren tone and Radio Rebroadcast will resume (if applicable).

- **Logic Input 3 (J5-PIN3)**

Apply +VDC continuously to **YELLOW** wire to activate OUTPUT12.

- **Dual Tone Input (j5-PIN4)**

While a siren tone is active, apply +VDC continuously to **GREY** wire to activate mix tone function for a multi-speaker effect. This function may be used even with single speaker set-up.

NOTE: While Mix Tone is activated, the effective sound pressure level (SPL) for each speaker will be lower than that of regular single tone. This is to protect the speaker from overloading by the secondary tone and provide better clarity of sound and speaker lifetime.

● **Programmable Analogue Input (J5-PIN6)**

This analog input can be programmed to activate other buttons, inputs, outputs, sirens, etc. depending on the input voltage (1VDC ~ 32VDC). By default, this input function is BACKLIGHT POWER ON:

- **Backlight ON Input (J5-PIN6)**

Apply +VDC continuously to **BLUE** wire to activate backlight on the handheld controller.

● **Radio Re-broadcast Input (J5-PIN7~PIN8)**

Connect **WHITE** and **BROWN** wires to the speaker output of a radio console.

4-PIN HIGH CURRENT RELAY OUTPUTS Harness (J6 Connector)

- **OUTPUT1~3 (J6-PIN1~PIN3)**

Connect to auxiliary devices power up to 15 Amps max.

- **N.A. (J6-PIN4)**

Not Used.

10-PIN MID/LOW CURRENT RELAY OUTPUTS Harness (J7 Connector)

- **OUTPUT4~5 (J7-PIN1~PIN2)**

Connect to auxiliary devices power up to 10 Amps max.

- **OUTPUT6 (J7-PIN3) & OUTPUT6 Dry Contact (J7-PIN4)**

OUTPUT6 may function in one of the two scenarios below based on its Fuse Position:

- **FUSE Position 1 - General Purpose Output (Factory Default)**

Connect J7-PIN3 to auxiliary devices power up to 10 Amps max.

- **FUSE Position 2 - Dry Contact Relay**

Connect J7-PIN3 (RED) and J7-PIN4 (ORANGE) each to one device where two devices will be connected when OUTPUT6 is activated.

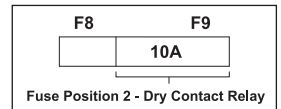
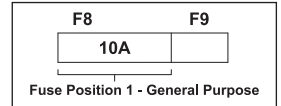

- **OUTPUT7~8 (J7-PIN6~PIN7)**

Connect to auxiliary devices power up to 2 Amps max. or use as Lightbar function activation switch.

- **OUTPUT9~12 (J7-PIN8~PIN10, PIN5)**

Connect to auxiliary devices power up to 0.25 Amps max. or use as Lightbar function activation switch.

DEFAULT OUTPUT WIRING

Unless otherwise re-programmed via PC software. By default, these Output wires function as Follow:

- **CODE1~CODE3 Output (J6-PIN1~PIN3)**

Connect each of the three outputs to power devices that will be turned ON and OFF with CODE1, CODE2 and CODE3 buttons respectively.

- **SW12~SW14 Output (J7-PIN1~PIN3)**

Connect each of the three outputs to power devices that will be turned ON and OFF with SW12, SW13 and SW14 button respectively.

- **Logic Input 3 Output (J7-PIN5)**

Connect this output to power devices that will be turned ON and OFF with Logic Input 3.

- **Horn-ring Warning Output (J7-PIN6)**

Connect this output to power devices that will be turned ON and OFF with Horn-Ring Transfer input or Air Horn button.

- **Icon Driver Output (J7-PIN7)**

Connect this output to power devices that will be turned ON and OFF with Siren Tone activation (excluding MAN Tone).

- **Traffic Arrow Outputs (J7-PIN8~PIN10)**

Connect these outputs to activation wires of a Traffic Arrow device that will be turned ON and OFF with TA button.

- J7-PIN8 to Left Arrow activation.
- J7-PIN9 to Right Arrow activation.
- J7-PIN10 to TA Warning activation

DEFAULT HAND-HELD CONTROLLER OPERATION

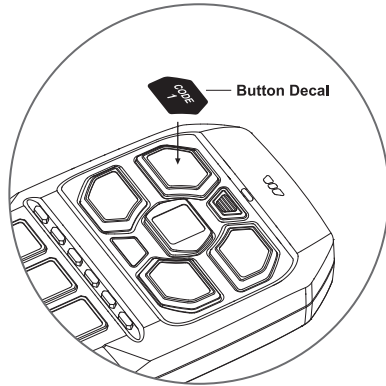
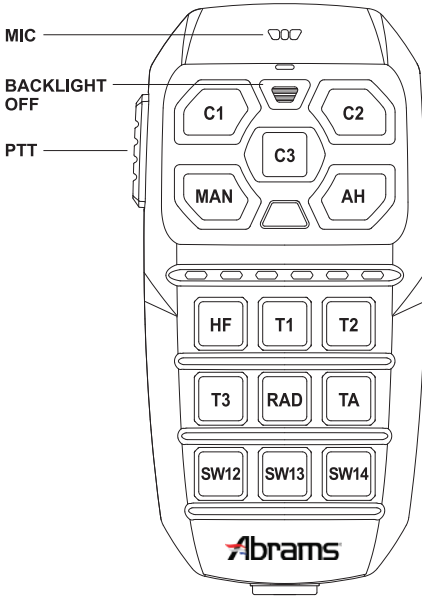

NOTE: The controller is shipped without any button decals installed. Place the desired decal onto each button.

- **PTT - PA Broadcast (BTN-PTT)**

Press and hold to activate Microphone for PA Broadcast through the siren speaker. This Button overrides all other acoustic functions (i.e. Air Horn, Siren Tone and Radio Rebroadcast) while it is activated

- **C1 - CODE1 (BTN1)**

Press once to activate or de-activate OUTPUT1.

- **C2 - CODE2 (BTN2)**

Press once to activate or de-activate OUTPUT2 and [C1].

- **C3 - CODE3 (BTN3)**

Press once to activate or de-activate OUTPUT3, [C2], [C1] and [T1].

If [T2] and [T3] is active when de-activating [C3], de-activate [T2] and [T3].

- **MAN (BTN4)**

- **When Siren Tone is not active:**

Activate momentary MAN WAIL tone when pressed. This tone will ramp up to sustain a specific pitch until released (stopped immediately).

- **When Siren Tone is active:**

Press once to change Primary Siren Tone to Override Tone (Based on the current active tone, Override Tone may differ); press again to revert back to Primary Siren Tone.

- **When HF Mode (Hands-Free) is active:**

Press once to start Siren Tone; press again to cycle through all HF Tone List; double press to end Siren Tone.

Default HF Tone List: WAIL > YELP > PHASER > HILO > ...

- **AH - AIR HORN (BTN5)**

Momentarily activate the AIR HORN tone and OUTPUT7 when it is pressed. This tone will override all other Siren Tones and Radio Rebroadcast while it is activated.

- **HF - HANDS-FREE (BTN6)**

Press [HF] once to enter HF Mode Standby; while in standby, press [MAN] button or [Horn-Ring Transfer] Input (J5-PIN1) once to start Siren Tone; press again to cycle through all HF Tone List; double press to end Siren Tone.

Default HF Tone List: WAIL > YELP > PHASER > HILO > ...

While [HF] is active (in standby or in siren tone), press [HF] again to exit HF Mode.

This Button will de-activate the [T1], [T2], [T3] and [RAD] upon activation.

- **T1 - WAIL (BTN7)**

Press once to activate or de-activate WAIL tone and OUTPUT8. While in WAIL tone, press [MAN] once to change Primary Siren Tone to Override Tone in YELP; press [MAN] again to revert back to WAIL tone. This Button will de-activate the [HF], [T2], [T3] and [RAD] upon activation.

- **T2 - YELP (BTN8)**

Press once to activate or de-activate YELP tone and OUTPUT8. While in YELP tone, press [MAN] once to change Primary Siren Tone to Override Tone in PHASER (a.k.a PIERCER); press [MAN] again to revert back to YELP tone. This Button will de-activate the [HF], [T1], [T3] and [RAD] upon activation.

- **T3 - PHASER/PIERCER (BTN9)**

Press once to activate or de-activate PHASER tone (a.k.a PIERCER) and OUTPUT8. While in PHASER tone, press [MAN] once to change Primary Siren Tone to Override Tone in HILO; press [MAN] again to revert back to PHASER tone. This Button will de-activate the [HF], [T1], [T2] and [RAD] upon activation.

- **RAD - RADIO REBROADCAST (BTN10)**

Press once to activate or de-activate Radio Rebroadcast tone. This Button will de-activate the [HF], [T1], [T2] and [T3] upon activation.

- **TA - TRAFFIC ARROW (BTN11)**

Press once to activate OUTPUT9 and LED indicator going left;
press again to activate OUTPUT10 and LED indicator going right;
press again to activate OUTPUT9, OUTPUT10 and LED indicator going left-right split;
press again to activate OUTPUT11 and LED indicator flashing randomly;
press again to OFF.

- **SW12 ~14 (BTN12~14)**

Press once to activate or de-activate OUTPUT4, OUTPUT5, OUTPUT6.

- **BACKLIGHT OFF (BTN15)**

Press once to de-activate or activate Green backlight; also dim Red backlight while it is activated. This Button will de-activate all current active buttons upon activation.

● QUICK REFERENCE

ID	Default Function	Description
PTT	PTT	Push-To-Talk (Microphone/PA).
BTN-B	BACKLIGHT OFF	Turns the backlight OFF.
BTN1	CODE1	Activates OUTPUT1.
BTN2	CODE2	Activates OUTPUT2, CODE1.
BTN3	CODE3	Activates OUTPUT3, CODE2, CODE1 & TONE1.
BTN4	MAN	Activates MANUAL tone; or Override Tone; or Change HF Tone.
BTN5	AIR HORN	Activates AIRHORN tone.
BTN6	HANDS-FREE MODE	Enter HF Mode; press MAN button to cycle through HF Tone List.
BTN7	TONE1	Broadcasts WAIL tone; press MAN button for YELP.
BTN8	TONE2	Broadcasts YELP tone; press MAN button for PHASER (PIERCER).
BTN9	TONE3	Broadcasts PHASER (PIERCER) tone; press MAN button for HILO.
BTN10	RADIO	Activates Radio Rebroadcast through the siren speaker.
BTN11	TRAFFIC ARROW	Cycles through Traffic Arrow, Left (OUTPUT9) > Right (OUTPUT10) > Split (OUTPUT9&10) > Warning (OUTPUT11) > Off
BTN12	SW12	Activates OUTPUT4.
BTN13	SW13	Activates OUTPUT5.
BTN14	SW14	Activates OUTPUT6.

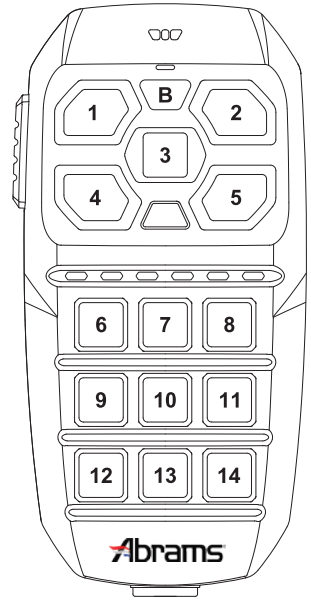

PC PROGRAMMING

All control buttons and function wires may be customized and re-programmed to user's preference for

Button modes,

Switch types,

- Press ON, Release OFF
- Press ON, Press OFF
- Press ON, Double Press OFF
- Press ON, Hold OFF
- Press ON, Timer OFF
- Double Press ON, Timer OFF

Shut Down Save Status,

Activation / Deactivation of,

- Each button / input / output / buzzer / tone / LED indicator / backlight

Tone Settings,

- Primary Tone / Override Tone / Mixer Tone
- HF Tone List
- Finish style

Volume,

Function precedence (priority),

Low voltage protection mode,

Shut Down delay,

and etc.

For more information about PC programming and Software, please refer to Software Manual or contact your sales representative.

INSTALLATION

Mounting

• Siren amplifier

1. Select a location that is not exposed directly to weather elements, such as the driver compartment firewall, below the seat, or in the trunk; avoid any interference of air bag deployment.
2. Using the siren amplifier as a template, mark four mounting holes to be drilled.
3. Drill four mounting holes for sheet metal screws.
4. Install the siren amplifier with provided sheet metal screws.

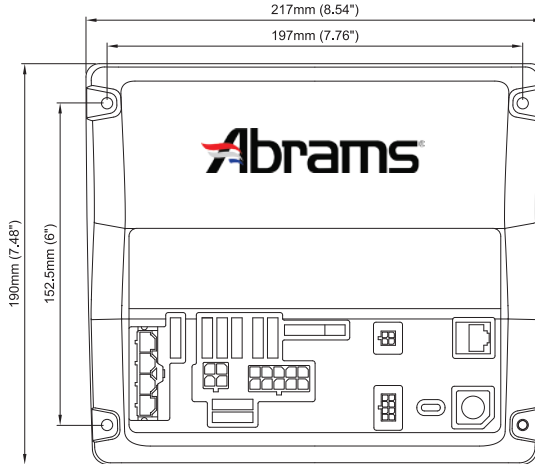

• Controller clip

1. Select a location where is convenient to the operator; avoid any interference of air bag deployment.
2. Using the mounting clip as a template, mark the two holes to be drilled.
3. Drill two mounting holes for sheet metal screws.
4. Install the microphone clip with provided sheet metal screws.

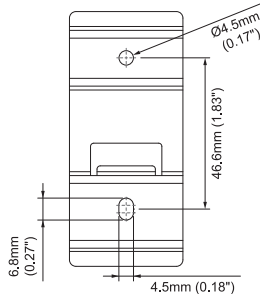

WARNING



PINCH HAZARD - Steel, iron and/or other ferrous objects may be attracted suddenly and forcefully to the magnets, creating the risk of pinch-type injuries. Keep all mild steel and iron tools and equipment well away from the magnets at all times.

IMPORTANT! - Be certain to keep the controller away from the mounting location until you've cleaned up any metal shavings or other debris.