



www.Abrams-MFG.com info@abramsmfg.com,
4716 New Utrecht Ave Brooklyn, NY 11219.

Installation and Operation Instructions

LED Forklift Light

Model: FSL-BA
Model: FSL-RA

Specifications

- Voltage: Multi-voltage 10 - 30VDC
- Beam: Arrow
- Mounting: Bracket mount
- LED Color: Blue or Red optional
- Lens: PC lens
- IP Rating: Ip67

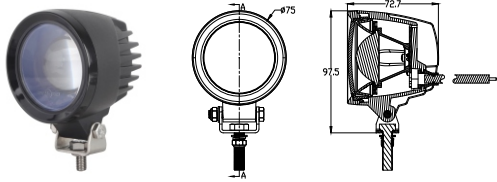

Safety First

This document provides all the necessary information to allow the product to be properly and safely installed. Before beginning the installation and/or operation of your new product, the installation technician and operator must read this manual completely. Important information is contained herein that could prevent serious injury or damage.

- ◆ Proper installation of this product requires the installer to have a good understanding of automotive electronics, systems and procedures.
- ◆ If mounting this product requires drilling holes, the installer **MUST** be sure that no vehicle components or other vital parts could be damaged by the drilling process. Check both sides of the mounting surface before drilling begins. Also de-burr the holes and remove any metal shards remnants. Install grommets into all wire passage holes.
- ◆ If this manual states that this product may be mounted with suction cups, magnets or tape, clean the mounting surface with a 50/50 mix of isopropyl alcohol and water and dry thoroughly.
- ◆ Do not install this product or route any wires in the deployment area of your air bag. Equipment mounted or located in the air bag deployment area will damage or reduce the effectiveness of the air bag, or become a projectile that could cause serious personal injury or death. Refer to your vehicle owners manual for the air bag deployment area. The User/Installer assumes full responsibility to determine proper mounting location, based on providing ultimate safety to all passengers inside the vehicle.
- ◆ For this product to operate at optimum efficiency, a good electrical connection to chassis ground must be made. The recommended procedure requires the product ground wire to be connected directly to the NEGATIVE (-) battery post (this does not include products that use cigar power cords).
- ◆ If this product uses a remote device for activation or control, make sure that this device is located in an area that allows both the vehicle and the device to be operated safely in any driving condition.
- ◆ Do not attempt to activate or control this device in a hazardous driving situation.
- ◆ This product contains either strobe light(s), halogen light(s), high-intensity LEDs or a combination of these lights. Do not stare directly into these lights. Momentary blindness and/or permanent damage to your eyesight may occur.

- ◆ Use only soap and water to clean the outer lens. Use of other chemicals could result in premature lens cracking (crazing) and discoloration. Lenses in this condition have significantly reduced effectiveness and should be replaced immediately. Inspect and operate this product regularly to confirm its proper operation and mounting condition. Do not use a pressure washer to clean this product.
- ◆ It is recommended that these instructions be stored in a safe place and referred to when performing maintenance and/or reinstallation of this product.



FAILURE TO FOLLOW THESE SAFETY PRECAUTIONS AND INSTRUCTIONS **COULD RESULT IN DAMAGE TO THE PRODUCT OR VEHICLE AND/OR SERIOUS INJURY TO YOU AND YOUR PASSENGERS!**

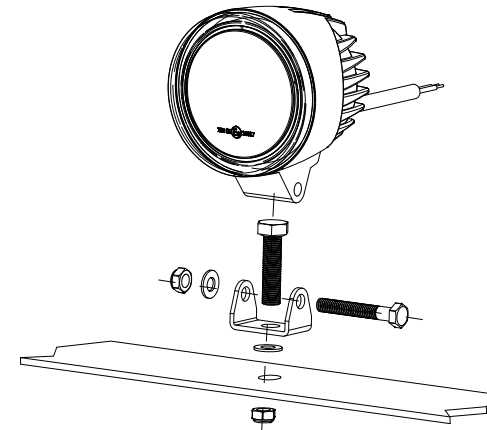

Bracket Mount

1. Position the hinge bracket onto the proposed mounting surface. Using the bracket as a template, mark the area where the mounting hole is to be drilled.

Caution: Permanent mounting of this product will require drilling. It is absolutely necessary to make sure that no other vehicle components could be damaged by this process. Check both sides of the mounting surface before starting. If damage is likely, select a different mounting location.

2. Drill a clearance hole for a bolt. Using the hardware provided, secure the bolt to the mounting surface.
3. Secure the lighthead to the hinge bracket as shown. When the lighthead is at the desired angle, tighten the hardware to hold that position.
4. Using appropriately sized wire, extend the RED wire to switched +12V/24V DC. Fuse this wire @3A. Extend the BLK wire to ground.



All customer supplied wires that connect to the positive terminal of the battery must be sized to supply at least 125% of the maximum operating current and FUSED at the battery to **carry that load**.



Before returning the vehicle to active service, visually confirm the proper operation of this product, as well as all vehicle components/equipment.