

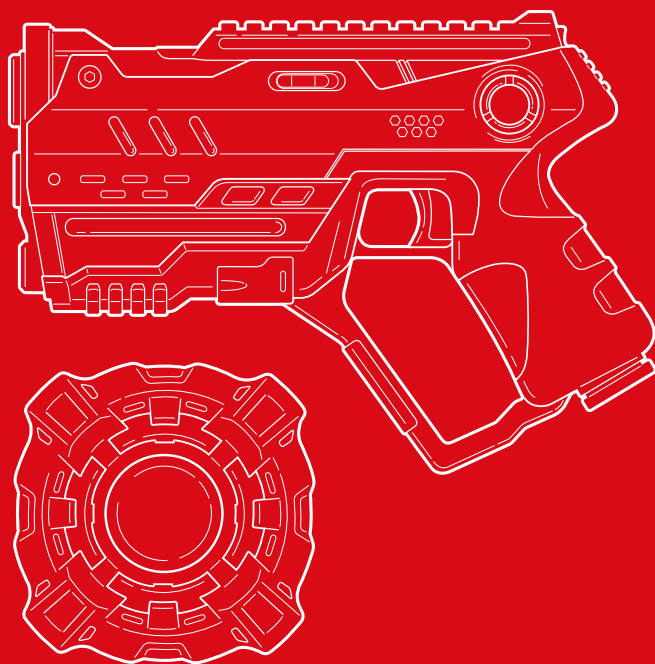

INSTRUCTION MANUAL



Laser Force PISTOLS WITH VESTS

**WAITING ON
ACTIVATION!**

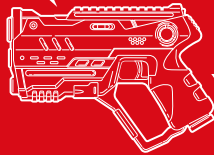

If gun says “*waiting on activation,*”
reset the gun to activate:

- 1.** Player on a different team points gun at deactivated gun and holds down the team selection button.
- 2.** The deactivated gun will say “full blood resurrection” and reset.
- 3.** Select desired team; health and ammo will reset.

bestchoiceproducts.com

NOTICE

Please retain these instructions for future reference.

- Avoid exposure to direct sunlight and excessive heat.
- Do not immerse product in water.
- Do not alter this product in any way as it may result in product failure.
- If any parts are missing, broken, damaged, or worn, stop using this product until repairs are made and/or factory replacement parts are installed.
- Do not use this item in a way inconsistent with the manufacturer's instructions as this could void the product warranty.

REQUIRED



PHILLIPS
SCREWDRIVER



3 AAA BATTERIES
PER GUN



3 AAA BATTERIES
PER VEST



1 PERSON
ASSEMBLY



APPROXIMATELY
5 MIN.
ASSEMBLY

PISTOL DIAGRAM

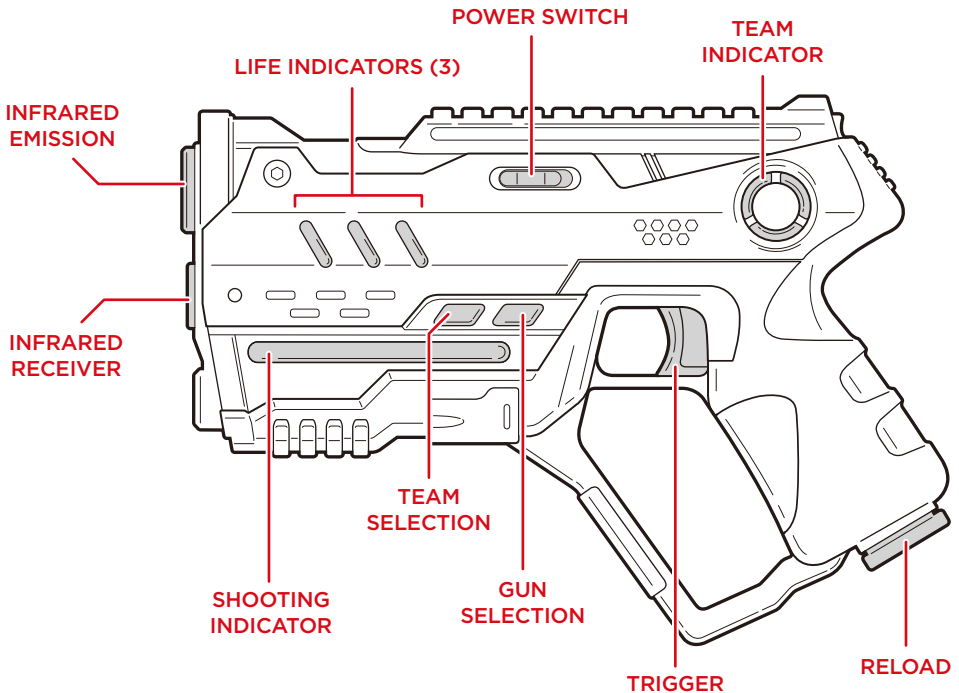

- **Life Indicators (3)**: Each life indicator represents 3 health (for a total of 9).
- **Low Battery**: The 3 life indicators will flash slowly to indicate that the blaster has low battery.
- **Max Strike Distance**: 130 feet

VEST DIAGRAM

LIGHT INDICATOR / INFRARED RECEIVER

LIFE INDICATORS (4)

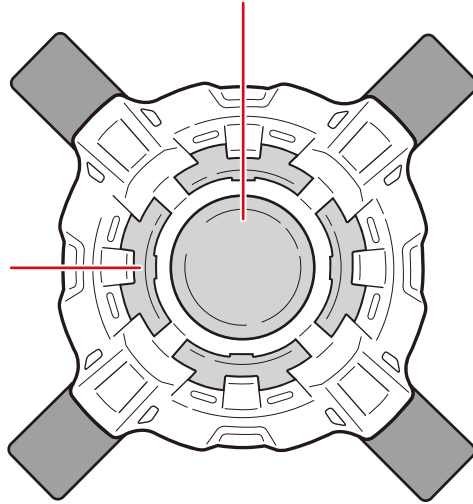

- **Infrared Receiver:** Vibrates and flashes colors when hit
- **Light Indicator:** Displays team color
- **Life indicators (4):** Each life indicator represents 3 health (for a total of 12)

NOTE: Pistols and vests have separate life indicators. The pistol has 9 health points and the vest has 12 health points; therefore, each player has combined 21 health points.

BATTERY INSTALLATION - PISTOL & VEST

1. Use a screwdriver to remove the battery cover.
2. Insert 3 AAA batteries. Make sure the batteries are inserted with the correct polarity.
3. Replace the battery cover.

PISTOL

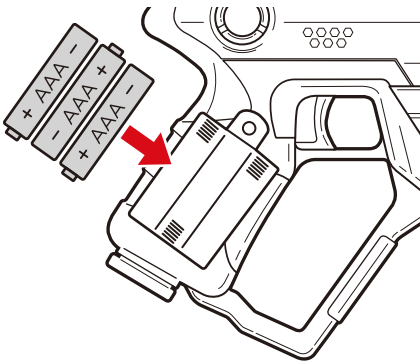

VEST

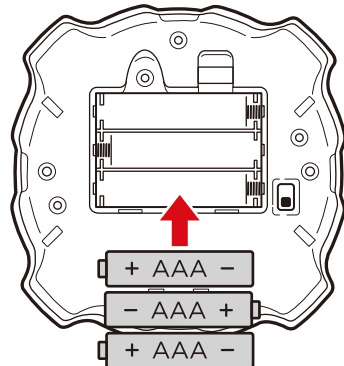

VEST INSTRUCTIONS

1. Place vest strap over your neck.
2. Fasten buckle in the back. Tighten straps to secure vest.

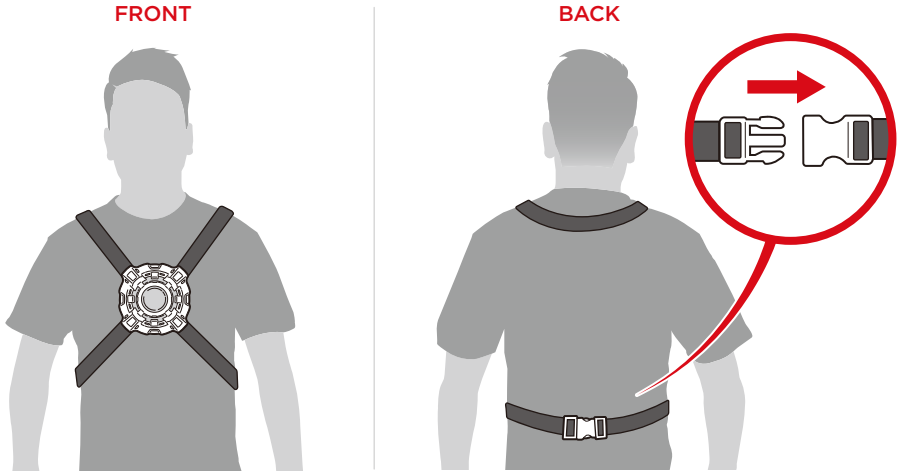

OPERATING INSTRUCTIONS

- 1 Switch the pistol on. The pistol will default to single shot mode.
- 2 Press the team selection button to toggle between teams. There are 4 colors to represent 4 possible teams – blue, red, green, or white. You cannot shoot your own team.
- 3 Switch the vest on and it will toggle different colors. Use the pistol to shoot the vest and the vest will turn the color of your team. The vest is now assigned to your team. You cannot shoot your own team's vest.
- 4 Press the gun selection button to toggle between 4 gun modes:

GUN MODES	Single Shot	Laser Gun	Machine Gun	Plasma Gun
SHOTS				
HEALTH REDUCED BY EACH SHOT				

When you run out of ammo, press the reload button under the grip to reload.

- 5 The pistol and the vest are infrared receivers with a different amount of health points (pistol has 9 health and vest has 12 health). Aim and shoot at an opponent's pistol or vest to register a hit. Once hit, the life indicator will reduce accordingly and the pistol/vest will vibrate and emit a sound. When your life indicator reaches 0, the indicators will flash and you will not be able to shoot anymore.

RESET PISTOL & VEST

- A player cannot change teams or reset a gun during a game.
- To reset a gun (if gun says “waiting on activation”) or change teams:
 1. Player on a different team points gun at your gun and holds down the team selection button.
 2. The gun will say “full blood resurrection” and reset.
 3. Select a new team; health and ammo will reset.
- To reset a vest, switch the vest off and on.

CARE

- If unused for a long period of time, remove the batteries.
- If necessary, clean this product with a damp cloth.

COMPATIBLE SETS

With the ability to mix and match Best Choice Products Laser Force Blaster Sets, you'll have more than enough blasters for your next event, birthday party, or family reunion!

TROUBLESHOOTING

PROBLEM	REASON	SOLUTION
Blasters do not work	Low battery	Replace the batteries
	Infrared signal could not reach the blaster because the distance is too far or angle is wrong	Reduce the firing distance and firing angle
	Obstacles blocking the infrared signal	Remove the obstacles
Blasters operate automatically	Low battery	Replace the batteries
	Overexposure to direct sunlight	Block sunlight or play in an area without direct sunlight
	Competing infrared transmission from other devices, such as TV remotes	Stop using or move away from competing infrared devices
Blaster says “waiting on activation”	Blaster deactivated	Reset blaster (see Reset Pistol & Vest section)

NOTE: If normal operation of the product is disturbed or interrupted, strong electro-magnetic interference may be causing a problem. Reset the product by turning it completely off and then back on. If normal operation does not resume, try replacing the batteries and moving the product to another location.

LASER PRODUCT WARNING

These toys are 100% safe. Our infrared blasters have been tested by a 3rd party product safety facility and determined to emit safe, infrared (non-visible) lights at less than a 1mW power output. No eye-protection is needed. It is similar to the lights used in a garage opener or TV remote. They are in conformance with Code of Federal Regulations 21 CFR 1040.10.

WARNINGS REGARDING BATTERIES

- Do not mix alkaline, standard (carbon zinc) and rechargeable (nickel hydride) batteries.
- Do not mix old and new batteries.
- Non-rechargeable batteries should not be charged.
- Rechargeable batteries should be charged under adult supervision only.
- Exhausted batteries should be removed.
- The supply terminals should not be short-circuited.
- Do not put batteries next to or in a heat source (fire, electronic heating device, etc.).
- Do not hit batteries against hard objects.
- Do not submerge batteries in water.
- Batteries should be inserted with the correct polarity.

FCC COMPLIANCE STATEMENT

This device complies with part 15 of the FCC rules. Operation is subject to the following two conditions: (1) This product may not cause harmful interference, and (2) this device must accept any interference received, including interference that may cause undesired operation.

NOTE: This equipment has been tested and found to comply with the limits for a Class B digital device, pursuant to part 15 of the FCC Rules. These limits are designed to provide reasonable protection against harmful interference in a residential installation.

This equipment generates, uses, and can radiate radio frequency energy and, if not installed and used in accordance with the instructions, may cause harmful interference to radio communications. However, there is no guarantee that interference will not occur in a particular installation.

If this equipment does cause harmful interference to radio or television reception, which can be determined by turning the equipment off and on, the user is encouraged to try to correct the interference by one or more of the following measures:

- Reorient or relocate the receiving antenna.
- Increase the separation between the equipment and receiver.
- Connect the equipment to an outlet on a circuit different from that to which the receiver is connected.
- Consult the dealer or an experienced radio/TV technician for help.

WARNING: Any changes or modifications to this unit not expressly approved by the party responsible for compliance could void the user's authority to operate the equipment.

Responsible party (contact for FCC matters only):

Quality Control Dept.
5642 Ontario Mills Parkway
Ontario, CA 91764



HELP CENTER



Question about your product? We're here to help. Visit us at:

help.bestchoiceproducts.com



Chat Support



Product Inquiry



Orders FAQ



Product Assembly



Returns & Refunds

PRODUCT WARRANTY INFORMATION

All items can be returned for any reason within 60 days of the receipt and will receive a full refund as long as the item is returned in its original product packaging and all accessories from its original shipment are included. All returned items will receive a full refund back to the original payment method. All returned items will not be charged a re-stocking fee.

All returned items require an RA (Return Authorization) number, which can only be provided by a Best Choice Products Customer Service Representative when the return request is submitted. Items received without an RA may not be accepted or may increase your return processing time. Once an item has been received by Best Choice Products, refunds or replacements will be processed within 5 business days.

All returns must be shipped back to the Best Choice Products Return Center at the customer's expense. If the reason for return is a result of an error by Best Choice Products then Best Choice Products will provide a pre-paid shipping label via email. Boxes for return shipping will not be provided by Best Choice Products, and is the customer's responsibility to either use the original shipping boxes or purchase new boxes.

Pictures may be required for some returns to ensure an item is not damaged prior to its return. Items returned are not considered undamaged until they are received by Best Choice Products and verified as such. All damages to items are the customer's responsibility until the item has been received by and acknowledge by Best Choice Products as undamaged.



WARNING

Manufacturer and seller expressly disclaim any and all liability for personal injury, property damage or loss, whether direct, indirect, or incidental, resulting from the incorrect attachment, improper use, inadequate maintenance, or neglect of this product.