

SMARTBANK PRO USER & INSTALLATION GUIDE

Revision: B

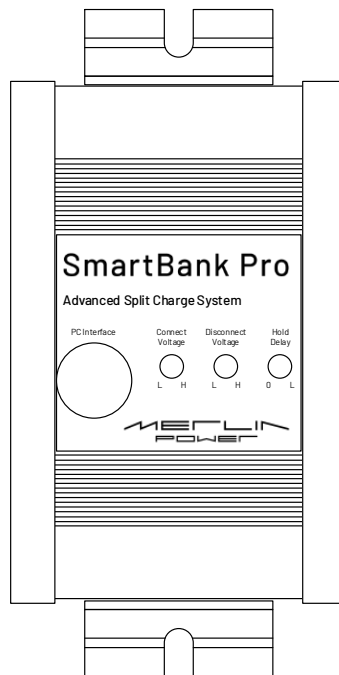

Merlin Equipment Ltd
Clyst Court
Hill Barton Industrial Estate
Exeter, Devon, EX5 1SA
United Kingdom
T: +44 (0)1202 697979

Merlin Power Systems
332-4 West Montauk Highway
Hampton Bays
New York NY11946
United States of America
T: +1(631) 594 5102

www.merlin-power.com

WARNING

Your attention is drawn to "Caution!" and "Warning!" statements throughout this manual.

"Caution!" refers to practices that may cause damage to the Merlin Product or your electrical system.

"Warning!" identifies practices that may cause injury or death.

SmartBank Pro is designed for installation by qualified and competent electrical engineers.

Qualified and competent engineers will be familiar with safe working practices, local health & safety legislation and the proper and safe use of tools and equipment.

Therefore not all obvious practices that may lead to system damage, injury or death are detailed within this manual.

If you are in anyway unsure about any aspect of the installation or use of SmartBank Pro, contact your Dealer or Merlin Power Systems for advice.

PRECAUTIONS

- This product is designed for use in 12 and 24 Volt DC vehicular systems depending on model. Use in other than its designed application may result in fire, electric shock or other injury.
- DO NOT disassemble, modify or alter. Doing so may result in an accident, fire or electric shock.
- USE ONLY in vehicles with a NEGATIVE GROUND. Failure to do so may result in fire, electric shock, damage or other injury.
- FUSES: Use the correct ampere rating when replacing fuses. Failure to do so may result in fire, injury, electric shock or damage.
- DO NOT install or operate the CPU in an explosive atmosphere.
- DO NOT install or expose the CPU to excessive temperatures or humidity.
- If in any doubt consult a suitably qualified and competent engineer or the supplier.
- DO NOT substitute Contactors or switches with any other types that have not been approved and tested.
- MAINTENANCE. If you have problems or suspect device failures DO NOT attempt to repair the unit yourself. Return it to your Dealer or Merlin for servicing.

APPROVALS AND CONFORMITY

CERTIFICATE OF CONFORMITY



Declaration of Conformity

Merlin Equipment Limited, hereby declares that the product marketed as SmartBank Pro is in compliance with the requirements of EU Electromagnetic Compatibility (EMC) Directive 2014/30/EU.

VCA Approval Number 10R-058879

 10R-058879

Test Report No: TRA-025367-38-00A



SmartBank Pro complies with RoHS (Reduction of Hazardous Substances) Directive 2011/65/EC. At the end of life, SmartBank Pro should be disposed of as normal electrical waste.

SmartBank Pro has been tested to and surpasses ISO-7637-2 for use Vehicles.

Signed:

A handwritten signature in blue ink, appearing to read 'James Hortop'.

James Hortop
Managing Director
Merlin Equipment Limited

INTRODUCTION

Thank you for choosing Merlin SmartBank Pro!

SmartBank Pro is a highly advanced split charging system for multiple battery banks.

SmartBank Pro may be used for split charging of two or three independent battery banks. It is supplied with either a single split charge contactor (for two battery banks) or two contactors (for three battery banks).

SmartBank Pro will operate on certain hybrid and electric vehicles and those fitted with both standard lead/acid, AGM, Gel and Lithium-Ion Batteries.

Please take the time to read and understand this manual before installation and use.

CONTENTS

WARNING.....	2
PRECAUTIONS	3
APPROVALS AND CONFORMITY.....	4
CERTIFICATE OF CONFORMITY.....	4
INTRODUCTION.....	5
CONTENTS.....	5
IDENTIFICATION OF SYSTEM COMPONENTS	6
INSTALLATION	7
POSITIONING OF PARTS	7
FIRST FIX INSTALLATION	7
ECU INSTALLATION	8
WIRING SCHEMATICS.....	9
NOTES.....	12
SET UP AND ADJUSTMENTS	13
PROGRAMMING.....	14
SMARTBANK PRO OPERATION.....	15
AFTER INSTALLATION	16
PRODUCT SPECIFICATIONS	16
PRODUCT ACCESSORIES.....	17
WARRANTY	17

IDENTIFICATION OF SYSTEM COMPONENTS

SmartBank Pro comprises a number of components. SmartBank Pro is configured for 2 or 3 battery bank installations, at 12 or 24 Volt DC. A number of additional components (e.g. Contactors, Switches) may also be used in the system.

SmartBank Pro Control Unit (ECU):

Contains main CPU and battery monitoring circuitry.



SmartBank Pro ECU

Contactors:

External contactors are used for split charge between battery banks.



Contactor

Standard contactors are rated at 200A continuous for both 12 & 24V systems.

Control Switch:

An Illuminated rocker switch can be provided for the switched input into the SmartBank Pro ECU. This can be used to provide emergency connection of the split charge contactor.



Attention: The Preview is based on a sample product; this can differ from the actual configuration supplied

Control Switch

SmartBank Pro control status can be communicated to the user via the LED contained within the switch. Alternatively, external LEDs can be provided.

INSTALLATION

Warning! Isolate power supply before starting installation.

POSITIONING OF PARTS

SmartBank Pro main components (ECU & Contactors) do not need to be easily accessible from a user's perspective. Only the control switch needs to be readily accessible to the user.

The following should be observed as parts of the SmartBank Pro are designed for wet / dirty environments, but others are not.

SmartBank Pro ECU:

The ECU is designed for location in a dry / clean environment. The ECU is **NOT** suitable for installation or operation in atmospheres where there is a risk of ignition or explosion. The ECU is **NOT** suitable for installation outside, under bonnet or in wet / damp cupboards.

Caution! Damage will occur if the ECU is allowed to get wet.

Warning! Do not install the ECU in a petrol/gas engine room environment.

Contactors:

The split charge contactors are designed to be installed under hood, in wet engine room environments and battery compartments. The contactor is IP66 rated and will withstand hose downs. The contactors should be located as close as possible to the associated batteries.

Emergency Parallel Switch:

The Switch is designed for location in a dry environment. It should be mounted on the dashboard or within easy view/access for the vehicle operator.

FIRST FIX INSTALLATION

Pre-Installation Preparation:

- Disconnect the main positive and negative from each battery bank to ensure no power is on the vehicle (up to 3 battery banks).
- Remove items (e.g. seats, access panels etc) to ensure easy installation.
- Survey the sites where you wish to locate components.

Mount Components:

Mount the components in the agreed locations with the specifying Engineer. We recommend installing directly to bulkheads using stainless steel bolts. All nuts should be either of the Nyloc type or protected with a shake proof washer. Appropriately sized washers should be used to mount components to distribute component weight and loadings.

Plan and lay in cables:

Lay in the cables / wiring to the various components as per the system diagram supplied by the specifying / design Engineer. Ensure all cables are routed away from vehicle control devices and are suitably fixed and secured. Cables and wiring should not be installed above vehicle access points.

ECU INSTALLATION

The SmartBank Pro ECU is supplied with 2 Mounting Flanges. Each flange has a mounting slot to enable fitment of M5 bolts. Ensure that the unit is securely mounted to the vehicle using suitable bolts, washers and nuts. Unit dimensions are as detailed below:

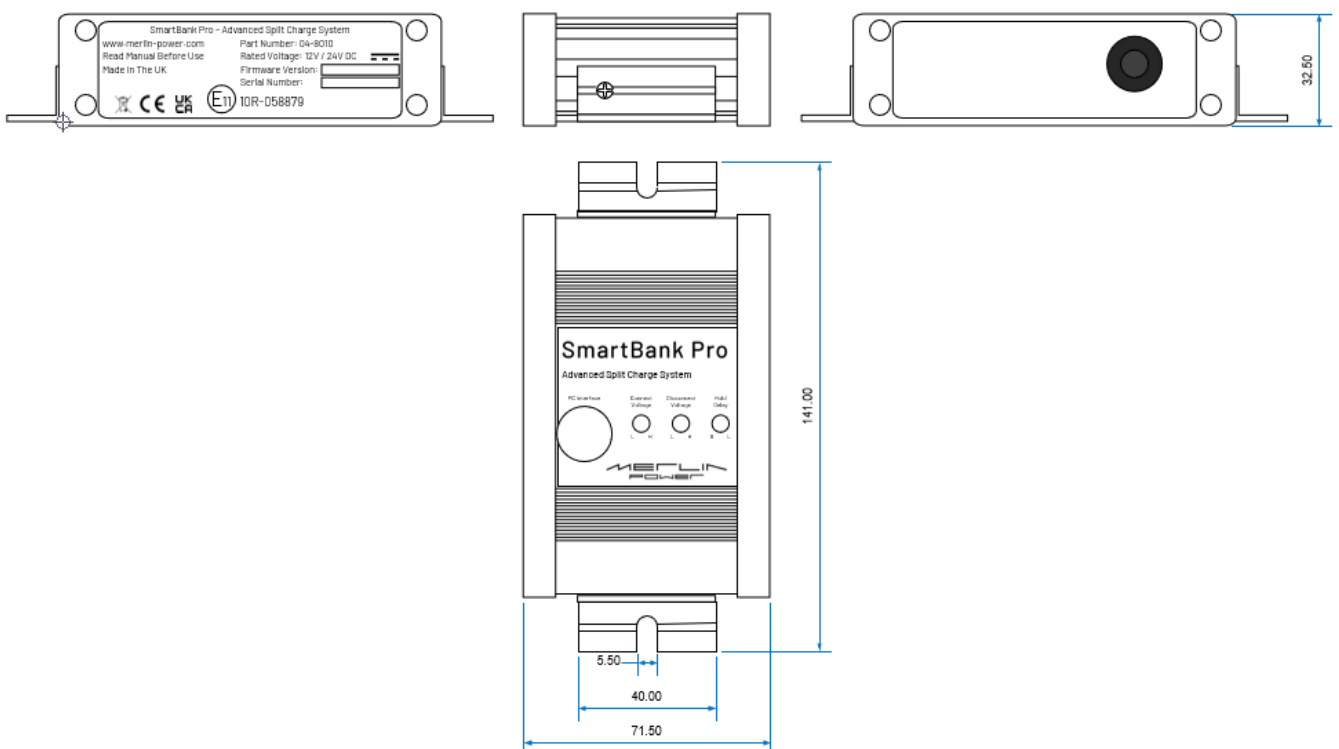

Note: Wiring loom omitted for clarity.

The SmartBank Pro wiring connections are as detailed within the Interface Control Document.

WIRING SCHEMATICS

TYPICAL SYSTEM LAYOUTS:

This section is for information only. Please check with the specifying / design engineer. However, these diagrams show a typical layout which will give you an understanding of how the systems install and the component parts required.

The following 2 Battery Bank Example is based upon a typical installation:

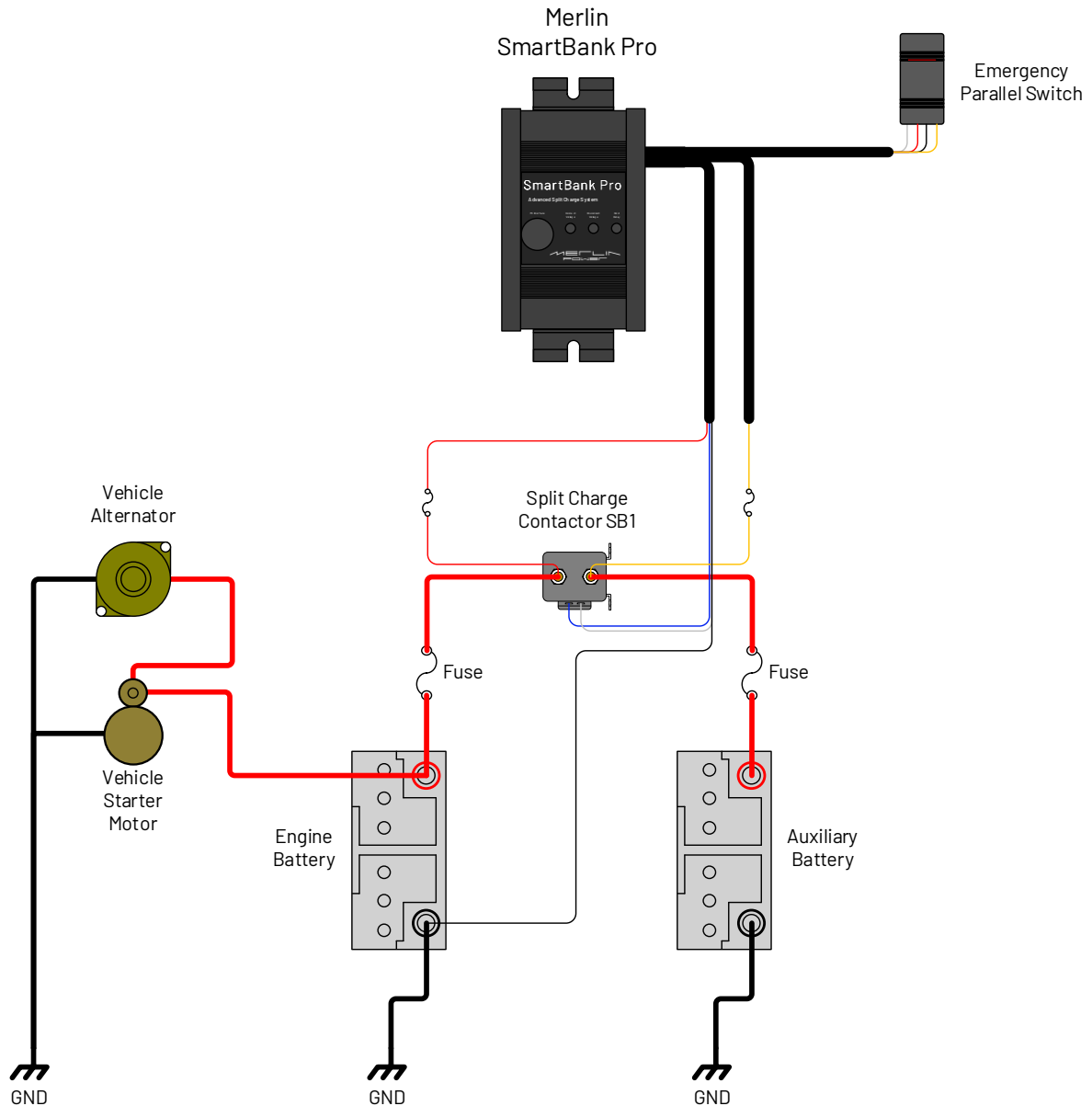

The following 3 Battery Bank Example is based upon a typical installation:

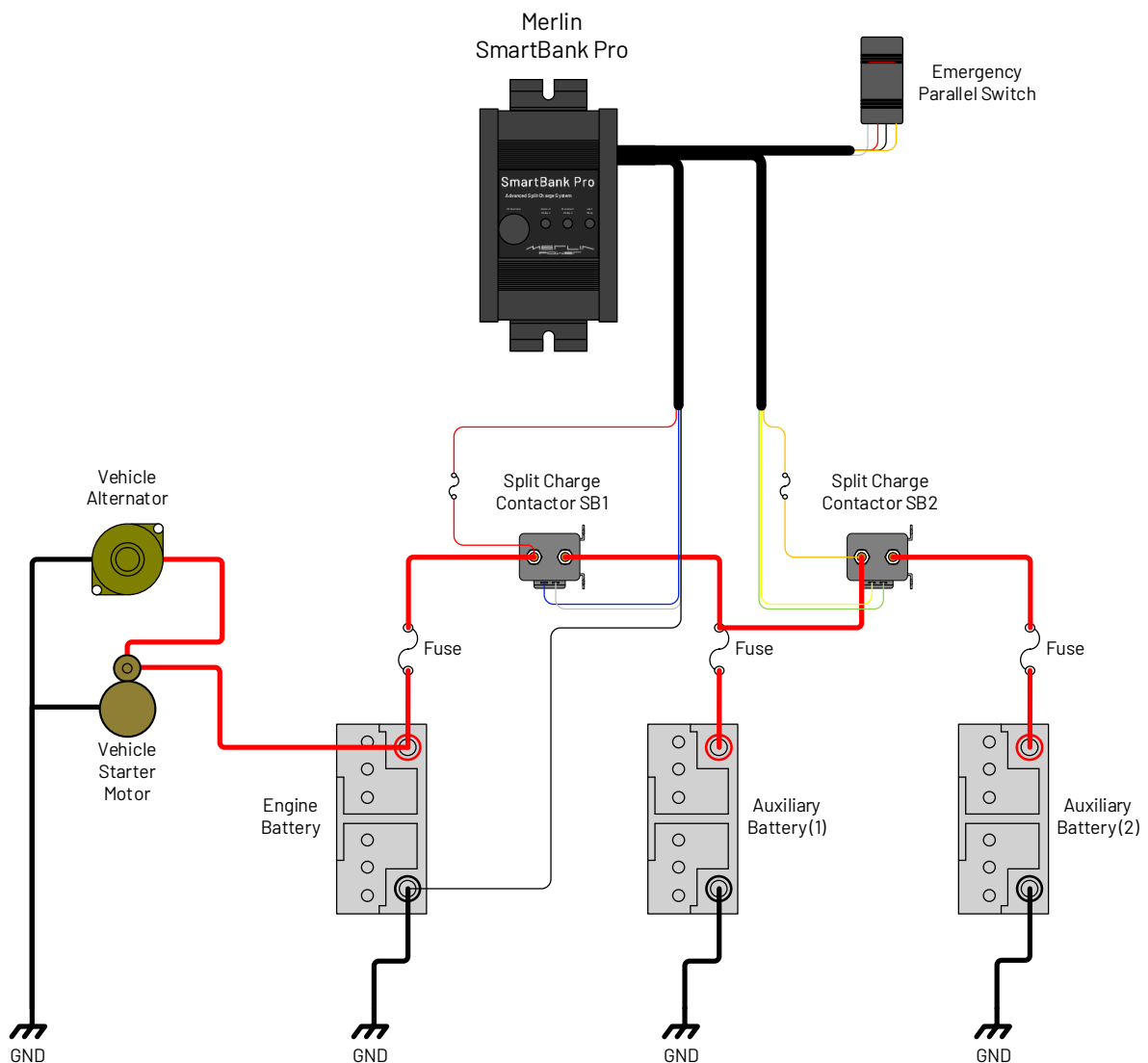

- *Caution! Ensure always that the correct polarity is observed on the SmartBank Pro wiring. Serious damage to the SmartBank Pro ECU will occur if wires are shorted or connected the wrong way around.*
- *Caution & Warning! We recommend that appropriately rated fuses or circuit breakers are inserted between batteries and SmartBank Contactors to protect against short circuits. These should be rated based upon maximum vehicle alternator output (Amps) or a maximum current rating of 200A.*
- Fuses should be located as close as possible to the battery positive terminal of each battery bank.
- High current cables must have a current rating higher than that of the associated fuse.

CONTROL & SENSE CABLING:

The SmartBank Pro is supplied with 3 separate wiring looms generally as per the diagram below:

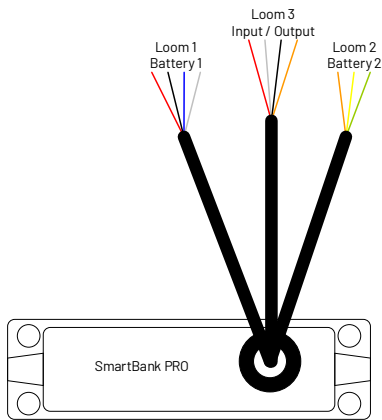

Loom connections are as follows:

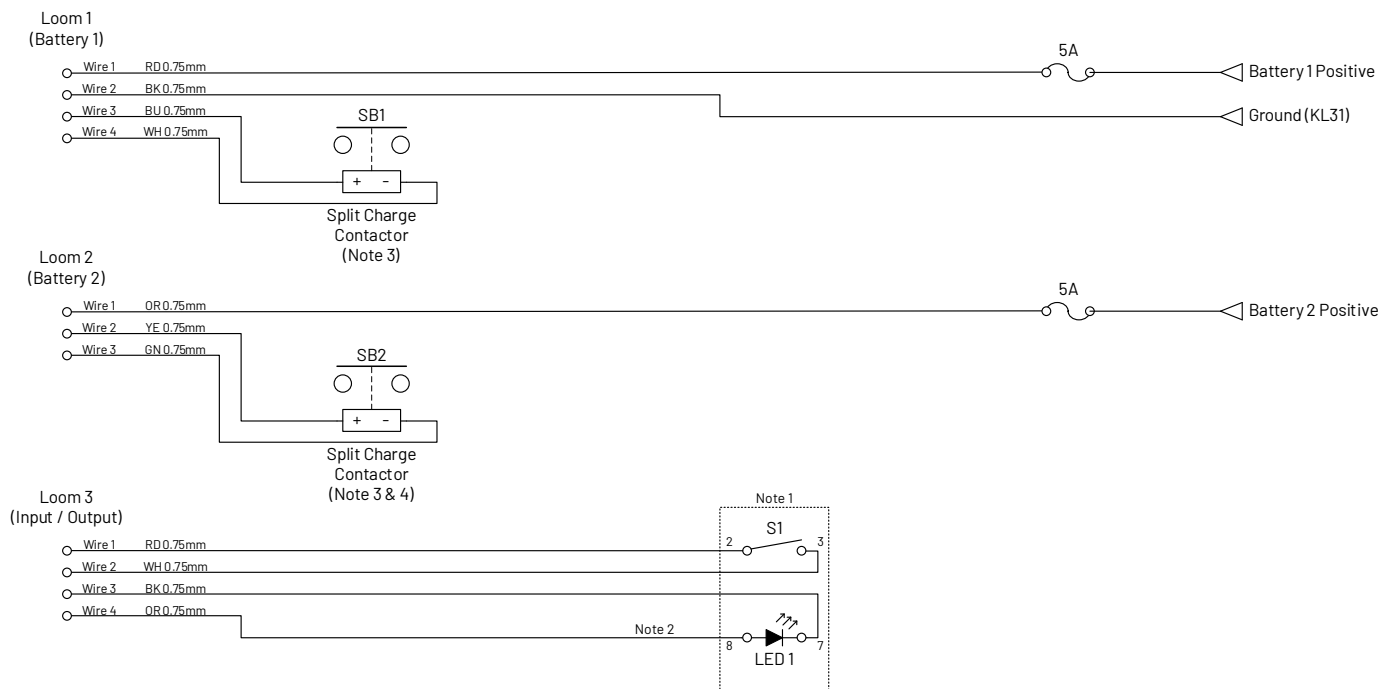

Note 1: Drawing details Carling type momentary switch with integral LED.

Separate Switch and LED can be utilised if required.

Note 2: LED Supply 5 Volt DC source with a 1K series limiting resistor.

Note 3: SmartBank contactor terminal connections are not handed.

Note 4: SB2 only used on 3 battery systems.

Note 5: Wire / cable wiring must comply with IPC/WHMA-A-620A.

- **Caution!** Care should be taken with the contactor coil connections. Serious damage to the SmartBank Pro will occur if wires are shorted or incorrectly connected.

NOTES

FINAL CHECKS:

Once cabling is complete. We highly recommend following the checklist below before reconnecting the main battery cables:

- *CAUTION! Incorrect and reverse polarity may damage the system.*
- *WARNING! Reverse polarity connections to batteries may cause them to explode. Check all cabling before powering up the system.*

PRE POWERUP-CHECKS:

- Check security of each component.
- Check main battery cables against system diagrams.
- Check main battery cables are correctly sized based upon rated loads.
- Check tightness of all connections.
- Ensure all live terminals are covered with rubber insulating boots.
- Check all negative connections are secure.

BATTERY CONNECTION:

Connect the batteries.

You will hear various clicks and clunks as the SmartBank Pro determines the position of contactors. Depending on unit status the switch LED may light.

DIGITAL SIGNAL PROCESSING:

SmartBank Pro senses and processes voltages using a Digital Signal Processing (DSP) which filters out transient spikes and electrical noise preventing contactors connecting and disconnecting erroneously.

The DSP operation means that the SmartBank Pro will take time to respond to sudden changes in voltage, so it may appear that there is a time-lag between the voltage reaching a certain level and the SmartBank Pro reacting to it. This is normal operation.

Bi-Directional Charging

SmartBank Pro acts as a Bi-Directional charge system. This means that it will sense charge on both engine and auxiliary batteries. Therefore, it will split charge when charge is applied to either the engine battery (via the alternator) or auxiliary battery (via a battery charger).

Note that SmartBank Pro has two voltage sensors and is bi-directional for Battery Banks 1 and 2. In systems using 3 battery-banks, the charge will be mono-directional for battery 3.

Therefore, if you wish for charge sources to charge all 3 batteries, they should be connected to battery banks 1 or 2.

SET UP AND ADJUSTMENTS

CONFIGURATION:

SmartBank Pro will work 'out of the box' for both 2 and 3 battery bank systems.

Manual adjustment of split charge settings is achieved using rotary trimming potentiometers ("trim pots") which are accessible through the front case of the ECU.

The trim pots on the front of the CPU allow you to adjust the Connect Voltage, Disconnect Voltage and Hold Timer settings.

- Connect range = 13.0 to 13.8 Vdc (26.0 to 27.6V for 24V Operation)
- Disconnect range = 12.5 to 13.3 Vdc (25.0 to 26.6V for 24V Operation)
- Hold timer range = 0 to 255 seconds.

Adjustment is made by rotating the trim pots using a trimming tool or a small (1.5mm) flat-blade screwdriver. These are accessed through holes in the front face of the enclosure. Protective blanking plugs cover the holes and need to be removed in order to adjust the trim pots.

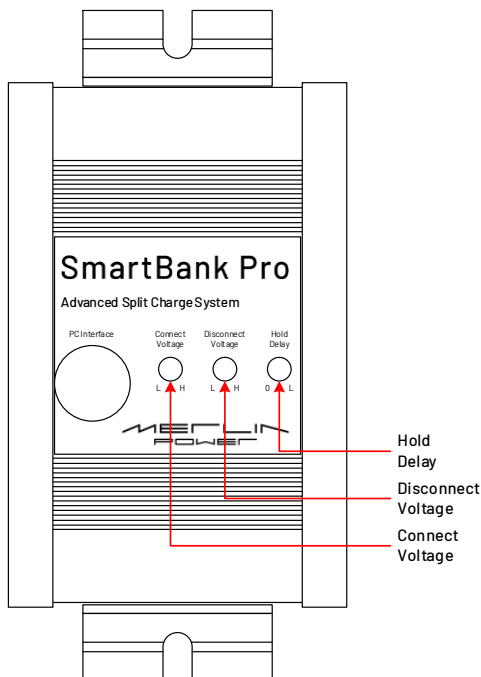

The left-hand trim pot adjusts the connection voltage threshold. The middle trim pot adjusts the disconnection voltage threshold. Voltage adjustment range is almost perfectly linear.

For example, with the control in the 12 o'clock position, this would be in the middle of the adjustment range (e.g. 13.4 Vdc for Connection).

The right-hand trim pot adjusts the time delay between zero and 255 seconds and again the adjustment is linear.

For a 3-battery bank system, split charge contactor SB2 will operate at the same Connect Voltage, Disconnect Voltage and Hold Timer settings as SB1. However, a small-time delay is built in which activates/deactivates the SB2 after SB1.

EMERGENCY PARALLEL SWITCH:

The emergency parallel switch (when pressed) will close the SB1 contactor and hold the engine and auxiliary battery in parallel for the same time period as the Hold Timer is set for. This allows for emergency jump starting of the engine, if the engine battery has been allowed to run flat or fails.

The LED on the emergency parallel switch will be illuminated whenever the split charge contactor is connected.

PROGRAMMING

SmartBank Pro can be supplied configured for vehicle applications where specific alternator charge profiles are used. These include:

- Smart Regenerative Charging Systems (SRCS)
- Euro 6 Configured Vehicles

In these instances, the trim pots on the unit will be disabled as specific configuration settings have been programmed within the unit.

Should the end user require custom programming, the SmartBank Pro can be supplied as an ECU only with external components as required. In this instance a 'Specifying Guide' will need to be completed by the specifying engineer. This should include (but not be limited to) the following information:

- Vehicle type
- Vehicle alternator rating (Amps)
- Auxiliary battery size (Ah) & type (e.g. Lead Acid / AGM)
- Maximum auxiliary battery bank loads
- Battery split charge connect / disconnect voltages
- System switch inputs required

Please ensure all programming requirements and parameters and any customer training needs are addressed by your specifying engineer before taking delivery of the unit.

SMARTBANK PRO OPERATION

SmartBank Pro has been developed as a total split charge product for 2 or 3 battery banks.

During normal operation the SmartBank Pro will monitor the voltages of both the engine and auxiliary batteries. Depending on these voltages it will carry out the following tasks:

1. Split Charge (SmartBank)

Should the engine or auxiliary battery voltage increased to above the configured 'Connect Voltage' the split charge contactor will connect and parallel the engine and auxiliary battery banks enabling split charging between the pair.

The red LED in the switch will also illuminate.

If a second split charge contactor is also fitted (3 battery banks), this will also connect after a short delay.

Should the connected battery pair(s) voltage discharge to below the configured 'Disconnect Voltage' for the preset 'Hold Delay' timer period, the contactor(s) will open separating the battery banks.

2. Emergency Parallel

The SmartBank Pro has the ability to parallel both the engine and auxiliary battery banks together to provide an emergency 'jump start' facility in the event of a flat engine start battery.

To operate the emergency parallel facility, press the 'Emergency Parallel' switch. The split charge contactor SB1 will connect for the 'Hold Delay' timer period and the LED will illuminate in the switch.

AFTER INSTALLATION

After installation and set-up, the blanking plugs (provided) should be fitted into the holes in the front of the unit. Note that they are designed to be difficult to remove so make sure you are finished before inserting them! The rubber blanking plugs restrict ingress of moisture and dirt into the ECU.

If you are unsure about any aspect please consult a suitably qualified engineer, your Dealer or Merlin Equipment Ltd before commissioning the unit.

PRODUCT SPECIFICATIONS

SmartBank Pro	
Part Number(s)	04-8010 (ECU Only) 04-8011 (12V 2 Batteries) 04-8012 (12V 3 Batteries) 04-8013 (24V 2 Batteries) 04-8014 (24V 3 Batteries) 04-8011-EURO6 (Euro 6 Vehicles) 04-8011-SRCS (SRCS Vehicles)
ECU Dimensions (Excluding Cables)	141 x 71.5 x 32.5mm (L x W x H)
ECU Weight	0.18Kg (Ex cabling) 0.36Kg (Inc cabling)
Voltage Rating	12 or 24V DC
Operational Input Voltage Range	6.5 to 36V DC
Operation Temperature Range (°C)	-25 to + 105°
Maximum Contactor Current	200A Continuous, 350A Peak
Current Consumption	10mA* <i>*Unit in idle state with no contactors or LEDs powered</i>
Maximum number of Battery Banks	3
Voltage Reading Range	0 to 19.3V or 38.6V (Dependant on 12 / 24V Setting)
Voltage Reading Accuracy	+/- 0.1V DC on 12V setting +/- 0.2V DC on 24V setting
LED Output	5V DC Source with 1K series limiting resistor
PC Communications	Serial - RS232 Communications

PRODUCT ACCESSORIES

Merlin Part Number	Description
19-5002	PowerGuard /SmartBank Pro Programming Lead
19-5014	Split Charge Contactor 12V
19-5015	Split Charge Contactor 24V
19-5018	Input Switch (On)-Off Momentary with Red LED
19-5019	Input Switch (On)-Off Momentary with Green LED
10-4012	Cable Cap Insulation Boot 2 - 2/0 AWG Red
10-4013	Cable Cap Insulation Boot 2 - 2/0 AWG Black
HWC/FHMG/1	Mega Fuse Holder
HWC/FME/200	200A Mega Fuse
HWC/ATOF/KIT	ATO Single Blade Fuse Holder
HWC/BF5	5 Amp Blade Fuse

WARRANTY

For details of our market-leading warranty policy, please refer to the FAQs section of the Merlin Power website: www.merlin-power.com



All details of the warranty policy are detailed here, to include duration, scope, claims procedure, limitations & governing law.

If your product requires troubleshooting or warranty service, contact your merchant. If you are unable to contact your merchant, or the merchant is unable to provide service, contact Merlin directly at: Merlin Equipment Ltd, Clyst Court, Hill Barton Industrial Estate, Exeter, Devon, EX5 1SA, United Kingdom. Tel: +44 (0)1202 697979.