



REF: QSF-030  
Issue: 1.0

## OneBox 75 User & Installation Guide

### Revision B



**Merlin Equipment Ltd**  
Clyst Court  
Hill Barton Industrial Estate  
Exeter, Devon, EX5 1SA  
United Kingdom  
T: +44 (0) 1202 697979

**Merlin Power Systems**  
332-4 West Montauk Highway  
Hampton Bays New York NY11946  
United States of America  
T: +1 (631) 594 5102

[www.merlinequipment.com](http://www.merlinequipment.com)



## WARNING

Your attention is drawn to **“Caution!”** and **“Warning!”** statements throughout this manual.

**“Caution!”** refers to practices that may cause damage to the OneBox 75 or your electrical system.

**“Warning!”** identifies practices that may cause injury or death.

***OneBox 75 is designed for installation by qualified and competent electrical engineers. Keep away from Children.***

***Qualified and competent engineers will be familiar with safe working practices, local health & safety legislation and the proper and safe use of tools and equipment. Therefore, not all obvious practices that may lead to system damage, injury or death are detailed within this manual. If you are in any way unsure about any aspect of the installation or use of OneBox 75, contact your Dealer or Merlin Equipment for advice.***



Merlin Equipment Ltd  
Clyst Court  
Hill Barton Industrial Estate  
Exeter, Devon, EX5 1SA  
United Kingdom

T: +44 (0) 1202 697979  
[www.merlinequipment.com](http://www.merlinequipment.com)

## Precautions

### ***Caution & Warning!***

- This product is designed for use in 12Volt DC systems only. Use in other than its designed application may result in fire, electric shock or other injury.
- DO NOT disassemble, modify or alter. Doing so may result in an accident, fire or electric shock.
- DO NOT cover or obstruct any air vent openings or install in a zero-clearance compartment.
- USE ONLY in vehicles with a NEGATIVE GROUND. Failure to do so may result in fire, electric shock, damage or other injury.
- External fuses (Not supplied with the unit) MUST be installed in each positive feed to the unit. Each fuse must be located as close to the battery terminal as possible (within 30cm).
- FUSES: Use the correct ampere rating when replacing fuses. Failure to do so may result in fire, injury, electric shock or damage.
- DO NOT install or operate the ECU in an explosive atmosphere.
- DO NOT install or expose the ECU to excessive temperatures or humidity.
- Install the ECU in a clean, dry environment. DO NOT install or expose the unit to wet or damp areas.
- If in any doubt consult a suitably qualified and competent engineer or the supplier.
- MAINTENANCE. If you have problems or suspect device failures DO NOT attempt to repair the unit yourself. Return it to your Dealer or Merlin for servicing.

## Approvals and Conformity

### Certificate of Conformity



#### Declaration of Conformity

Merlin Equipment Limited, Trading as Merlin Power Systems hereby declares that the product marketed as OneBox 75 is in compliance with the requirements of EU Electromagnetic Compatibility (EMC) Directive 2014/30/EU

VCA Approval Number: 10 R-05/01 10493 00



Approval No: E11\*10R05/01\*10493\*00

Test Report: 3C18/13465-1



OneBox complies with RoHS (Reduction of Hazardous Substances) Directive 2011/65/EC.  
At the end of life, OneBox should be disposed of as normal electrical waste.  
OneBox has been tested to and surpasses ISO-7637-2 for use on vehicles.

Signed:

A handwritten signature in blue ink, appearing to read 'James Hortop'.

James Hortop  
Managing Director  
Merlin Equipment Ltd

## **Introduction**

Thank you for choosing Merlin OneBox 75!

OneBox 75 is a complete power management system designed to facilitate both split charging and auxiliary flat battery protection in a single compact unit. You can also protect the engine start battery with an optional external contactor.

OneBox 75 overcomes the issues presented by modern Euro 6 and Euro 7 compliant vehicles where standard battery management systems fail to operate correctly. The system will also operate on certain hybrid and electric vehicles and those fitted with both standard lead/acid, AGM, Gel and Lithium-Ion Batteries.

OneBox 75 is CANbus enabled and can both broadcast and receive data over J1939 CAN Protocol.

3 power saving modes are available to ensure that OneBox 75 presents as smaller load as practically possible to the electrical system to ensure that batteries do not run flat when vehicles are not used for extended periods of time.

***CAUTION! Please take the time to read and understand this manual before installation and use.***

## **Contents**

Precautions .....	3
Approvals and Conformity .....	4
Certificate of Conformity .....	4
Introduction .....	5
Contents .....	6
Identification of System Components .....	7
Installation.....	9
Positioning of Components .....	9
First Fix Installation .....	10
OneBox 75 Installation .....	11
Wiring Schematics.....	12
OneBox 75 ECU Connections & Wiring: .....	12
Typical System Layout .....	13
Notes .....	15
Programming.....	16
OneBox 75 Operation.....	18
After Installation .....	20
Product Specifications.....	20
DC-DC Converter Efficiency Graph .....	21
Torque Settings .....	21
Product Accessories .....	21
Warranty .....	22

## Identification of System Components

OneBox 75 comprises of a number of components. OneBox 75 is configured for 2 battery bank installations, at 12 Volt DC. A number of additional components (e.g. Contactors, Switches) may also be used in the system.

OneBox 75 Control Unit (ECU):

Contains main CPU, split charge contactor, DC-DC converter, auxiliary battery isolation contactor, contactor control and battery monitoring circuitry.



OneBox 75 ECU and associated connectors

Insulating Boots:

OneBox 75 is supplied with 4. No Red and 1. No Black Terminal Insulating Boots.



Insulating Boots

Contactors:

An external contactor may also be used to isolate the engine battery.



Contactor

Standard contactor is rated at 200A continuous for 12V systems.

## Control Switches:

Illuminated rocker switches can be provided for the switched inputs into the OneBox 75 ECU. These can be used to control of the isolation contactors and to provide emergency connection of the split charge contactor.

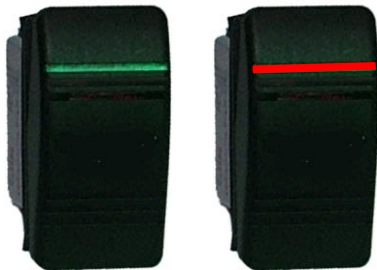

*Attention: The Preview is based on a sample product, this can differ from the actual configuration supplied.*

Control Switches

OneBox 75 Control Status can be communicated to the user via the LEDs contained within the switch. Alternatively, external LEDs can be provided.

Up to 4 Switches can be required per vehicle as follows:

- Isolate Engine Battery Switch
- Isolate Auxiliary Battery Switch
- Emergency Battery Parallel
- Override Switch

## System Cabling:

OneBox 75 can be supplied with a mating wiring loom for connecting to external components.



**Caution! Please ensure familiarity with the wiring of cable connectors, switches etc. It is highly recommended only personnel that have undertaken correct training attempt these tasks.**

**Warning! Incorrectly connected cables may damage OneBox 75 or vehicle electrics and will invalidate the Warranty.**



## Installation

**Warning!** Isolate all power supply sources before starting installation.

### Positioning of Components

OneBox 75 main components (ECU & Contactors) do not need to be easily accessible from a user's perspective. Only the control switches need to be readily accessible to the user.

The following should be observed as parts of the OneBox 75 are designed for wet/dirty environments, but others are not.

OneBox 75 ECU:

The ECU is designed for location in a dry / clean environment. The ECU is **NOT** suitable for installation or operation in atmospheres where there is a risk of ignition or explosion. The ECU is **NOT** suitable for installation outside, under bonnet or in wet / damp cupboards.

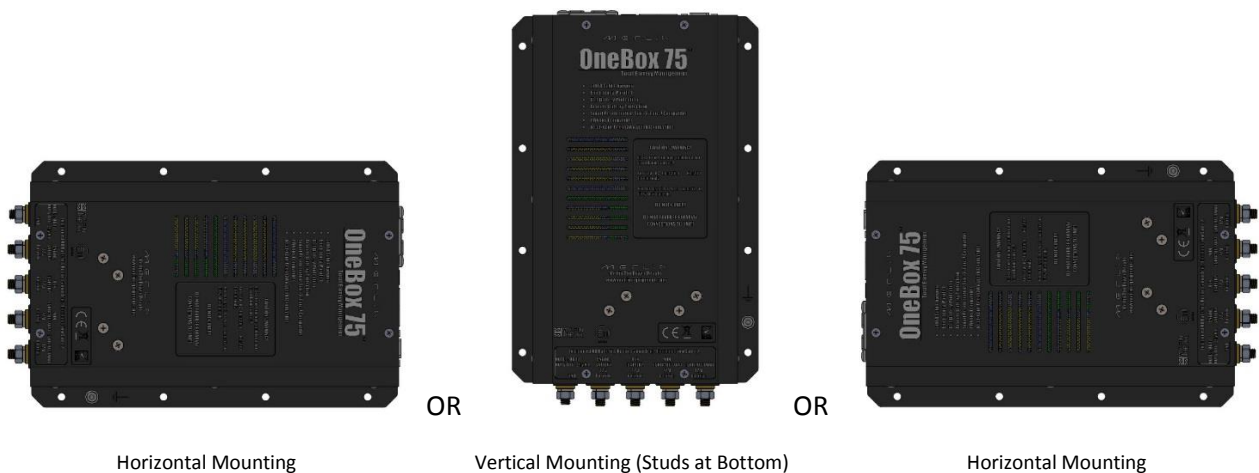

The ECU is recommended to be mounted horizontally, or vertically with the connection Studs at the bottom. It can also be mounted above or below a flat surface as detailed below.



**Caution! Damage will occur if the OneBox 75 ECU is allowed to get wet.**

**Warning! Do not install the OneBox 75 ECU in a petrol/gas engine room environment.**

### Contactors:

The external isolation contactor is designed to be installed under hood, in wet engine room environments and battery compartments. The contactor is IP66 rated and will withstand hose downs. The contactor should be located as close as possible to the engine battery.

### Control Switches:

The Switches are designed for location in a dry environment. They should be mounted on the dashboard or within easy view/access for the vehicle operator.

## First Fix Installation

### Pre-Installation Preparation:

- Disconnect the main positive and negative from each battery bank to ensure no power is on the vehicle (up to 2 battery banks)
- Remove items (e.g. seats, access panels etc) to ensure easy installation
- Survey the sites where you wish to locate components.

### Mount Components:

Mount the components in the agreed locations with the specifying Engineer. We recommend installing directly to bulkheads using stainless steel bolts. All nuts should be either of the Nyloc type or protected with a shake proof washer. Appropriately sized washers should be used to mount components to distribute component weight and loadings.

### Plan and lay in cables:

Lay in the cables / wiring to the various components as per the system diagram supplied by the specifying / design Engineer. Ensure all cables are routed away from vehicle control devices and are suitably fixed and secured. Cables and wiring should not be installed above vehicle access points.

## OneBox 75 Installation

The OneBox 75 ECU is supplied with 2 Mounting Flanges. Each flange has 4 mounting holes (Totals 8 Number) to enable fitment of 8 x M6 bolts. Ensure that the unit is securely mounted to the vehicle using suitable bolts, washers and nuts. Unit dimensions are as detailed below:

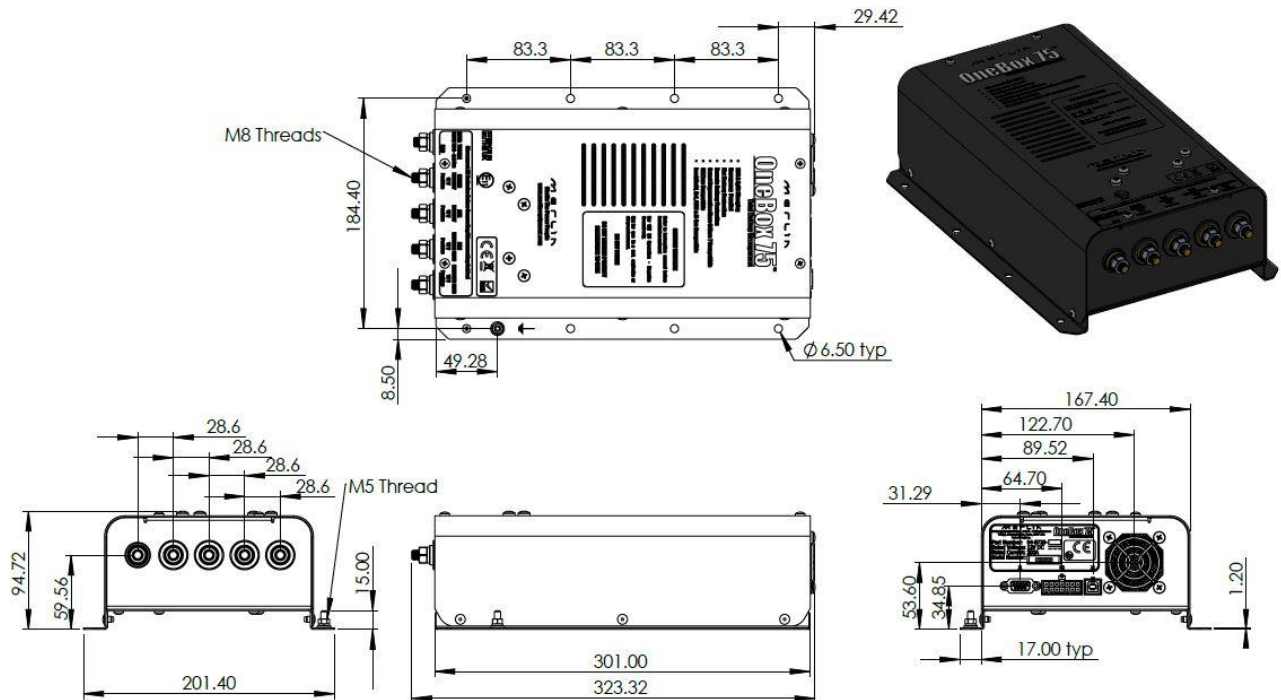

The OneBox 75 ECU can be supplied with an external loom for connecting to the control switches and any required control inputs.

The OneBox 75 wiring connections are as detailed within the OneBox Interface Control Document.

The OneBox 75 ECU is fitted with an external M5 Stud for connecting the case to chassis ground.

**Caution! Not grounding the casing may render the system non-EMI compliant.**

## Wiring Schematics

### OneBox 75 ECU Connections & Wiring:

#### OneBox 75 Connections:



OneBox 75 connection and earth stud torque settings are as detailed on page 20 of this manual.

- **Caution! Ensure always that the correct polarity is observed on the OneBox 75 wiring. Serious damage to the OneBox 75 ECU will occur if wires are shorted or connected the wrong way around.**
- **Caution! Ensure always that the correct torque setting is applied to the OneBox 75 connections and earth stud. Serious damage to the OneBox 75 ECU will occur if the fixings are overtightened.**

## Typical System Layout

This section is for information only. Please check with the specifying / design engineer. However, these diagrams show a typical layout which will give you an understanding of how the systems install and the component parts required.

The following 2 Battery Bank Example is based upon a typical installation.

### **Battery (High Current) Cabling:**

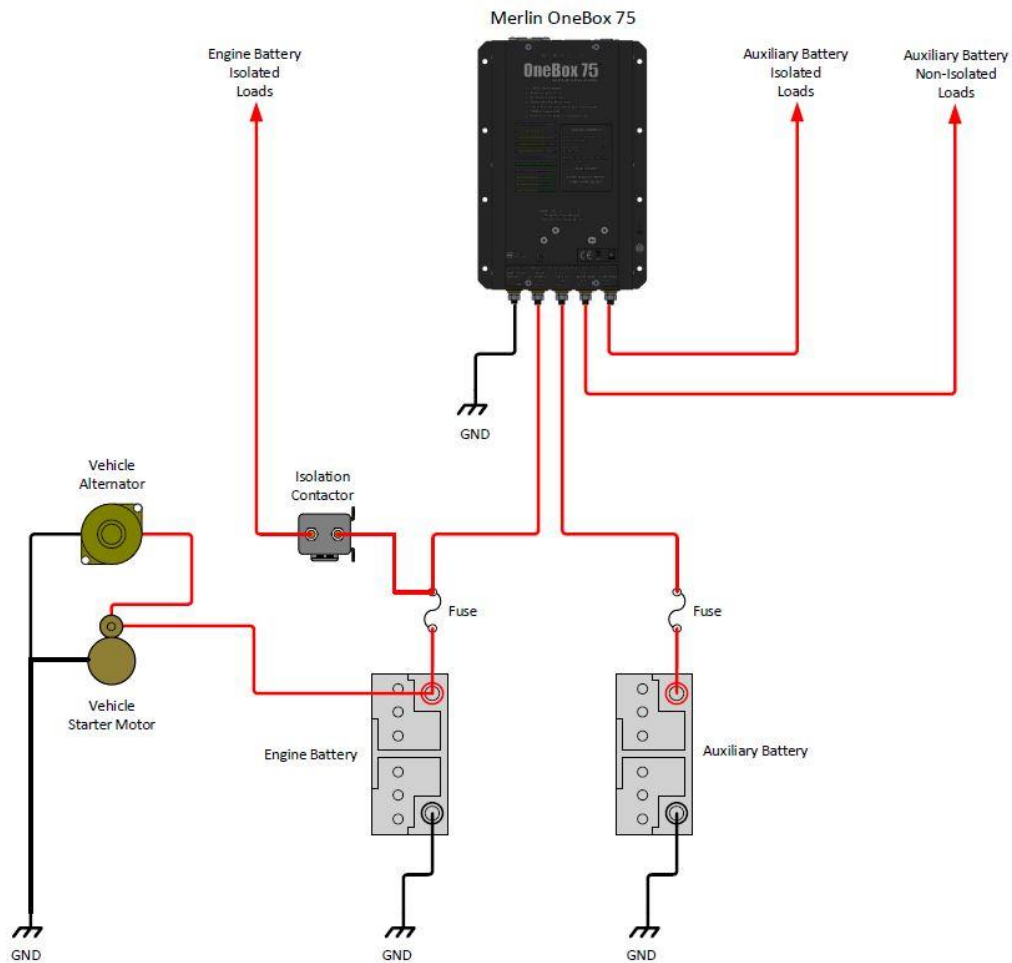

- **Caution & Warning!** We recommend that appropriately rated fuses or circuit breakers are inserted between batteries and OneBox 75 to protect against short circuits. These should be rated based upon maximum vehicle alternator output (Amps) or a maximum current rating of 200A.
- Fuses should be located as close as possible to the battery positive terminal of each battery bank
- High current cables must have a current rating higher than that of the associated fuse.
- OneBox 75 main ground cable must have the same current rating as the associated battery cabling.
- OneBox 75 high current cables must be fitted with supplied insulating boots to reduce the possibility of accidental short circuits.

- Consideration will need to be given to voltage drop based upon cable run lengths and cables should be sized accordingly.

Battery connection cables should be sized based upon the following table. The length detailed is based upon the total length from the engine to auxiliary battery banks.

Length (m)*	3.0	4.5	6.0	7.5	9.0
Cable Size (mm <sup>2</sup> )	35	50	70	95	120
Cable Size (AWG)	2	1/0	2/0	3/0	4/0

\*Based upon finely stranded extra flexible high current cable

### Control and Sense Cabling:

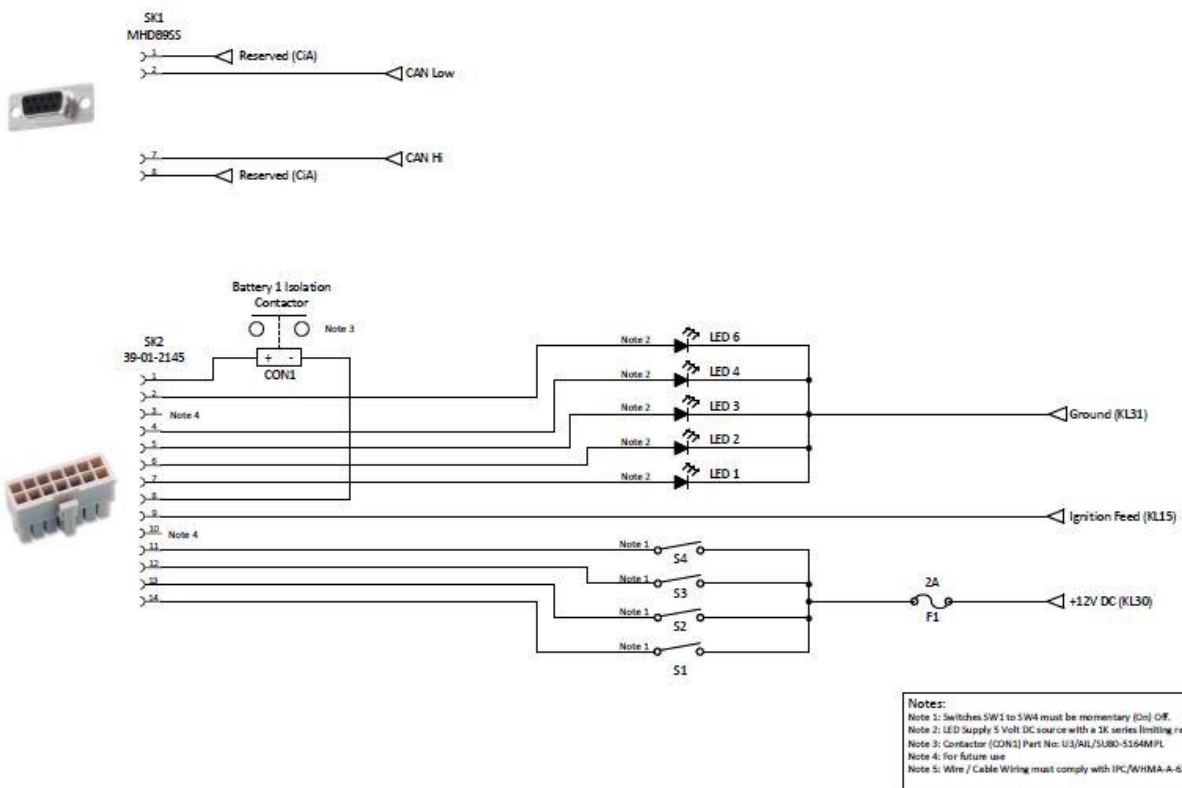

- **Caution & Warning! OneBox 75 switch supply wiring requires protection with a small inline fuse. This should be rated at 2A DC and used in every installation.**
- Depending upon installation requirements, the above inputs and outputs may or may not be required. Please check with the specifying Engineer as to actual system requirements.

## Notes

### Final Checks:

Once cabling is complete. We highly recommend following the checklist below before reconnecting the main battery cables

- ***CAUTION! Incorrect and reverse polarity may damage the system.***
- ***WARNING! Reverse polarity connections to batteries may cause them to explode. Check all cabling before powering up the system.***

### Pre-Powerup Checks:

- Check security of each component
- Check OneBox 75 casing is bonded to the chassis
- Check main battery cables against system diagrams
- Check main battery cables are correctly sized based upon rated loads
- Check tightness of all connections
- Ensure all live terminals are covered with rubber insulating boots
- Check all negative connections are secure

### Digital Signal Processing:

OneBox 75 senses and processes voltages using a Digital Signal Processor (DSP) which filters out transient spikes and electrical noise preventing contactors connecting and disconnecting erroneously.

The DSP operation means that the OneBox 75 will take time to respond to sudden changes in voltage, so it may appear that there is a time-lag between the voltage reaching a certain level and the OneBox 75 reacting to it. This is normal operation.

### Battery Connection:

Connect the batteries.

You will hear various clicks and clunks as OneBox 75 determines the position of contactors.

Depending on unit status the switch LEDs will light.

## **Programming**

OneBox 75 is factory shipped as a pre-programmed system depending on the specifying Engineers requirements. Depending on actual requirements the system may be supplied with external switches, LEDs, contactors and connection looms.

The standard operation of the switch inputs and LED outputs are as follows:

### Switch 1:

If the engine battery is connected, pressing the switch will manually isolate it.

If the engine battery is manually isolated, **or** the flat battery protection has isolated it, pressing the switch will reconnect it and reset the flat battery protection system.

### Switch 2:

If the auxiliary battery is connected, pressing the switch will manually isolate it.

If the engine battery is manually isolated, **or** the flat battery protection has isolated it, pressing the switch will reconnect it and reset the flat battery protection system.

### Switch 3:

Emergency battery parallel. Pressing the switch will cause the engine and auxiliary batteries to be paralleled for a period of 90 seconds. This is to enable emergency starting of the vehicle in the event of a flat engine battery.

### Switch 4:

Override function. Resets both flat battery protection, reconnects manual isolation and forces an emergency battery parallel.

### Switch 5:

Not currently used.

### Switch 6:

Ignition / engine run input. This input should be connected to the output from the ignition switch or an engine run signal.

- ***Caution! Switches 1-4 must be momentary (On) Off operation.***



#### LED 1:

LED 1 is related to the engine battery (for both manual isolation and flat battery protection).

LED On Continuously: Battery connected

LED Flashing On/Off: Flat Battery Protection in timer mode.

LED Intermittent Flashing: Battery disconnected due to Flat Battery Protection.

LED Off = Manually isolated.

#### LED 2:

LED 2 is related to the auxiliary battery (for both manual isolation and flat battery protection).

LED Continuously On: Battery connected

LED Flashing On/Off: Flat Battery Protection in timer mode.

LED Intermittent Flashing: Battery disconnected due to Flat Battery Protection.

LED Off: Manually isolated.

#### LED 3:

LED 3 is related to the split charge system.

LED Continuously On: DC-DC Converter active.

LED Flashing Intermittent: Battery Parallel (split charging via contactor).

LED Flashing On/Off: Emergency Battery Parallel (switch 3 has been activated).

LED Off: No split charge is taking place.

#### LED 4:

LED On: Internal fault.

#### LED 5:

LED 5 is not currently used.

#### LED 6:

LED 6 is related to the OneBox operation.

LED Continuously On: OneBox fully operational.

LED Flashing Intermittent: OneBox in sleep mode.

LED Flashing On/Off: OneBox in wake mode.

LED Off: OneBox is hibernating.

The OneBox 75 programming (e.g. DC-DC converter control, contactor operation, voltage thresholds) will need custom programming. If this is a multi-unit install (e.g. Vehicle Production Line) such specific programming should have happened prior to installation. If this is a one-off installation, or one where modifications have had to be completed 'on the line', you may need to upload the configuration file.

To ensure all programming requirements are captured a 'Specifying Guide' will need to be completed by the specifying engineer. This should include (but not be limited to) the following information:

- Vehicle type
- Vehicle alternator rating (Amps)
- Auxiliary battery size (Ah) & type (e.g. Lead Acid / AGM)
- Maximum auxiliary battery bank loads
- Flat battery protection isolation voltage
- Battery split charge connect / disconnect voltages
- System switch inputs required
- J1939 CAN output address (if required)

Please ensure all programming requirements and parameters and any customer training needs are addressed by your specifying engineer before taking delivery of the unit.

## **OneBox 75 Operation**

OneBox 75 has been developed as a product to overcome problems associated with split charging auxiliary battery banks on vehicles equipped with Smart Regenerative Charging Systems (SRCS). This includes Euro 6 & Euro 7 emission standard vehicles.

In these systems the vehicle alternator does not charge the engine battery during normal engine run time, instead the battery is charged during vehicle coasting or braking. This makes use of 'free' energy as gravity is providing the power to charge the battery.

In addition, the battery status and charge levels are monitored by the vehicle Engine Management System (EMS) and additional charge may be applied to the engine battery to maintain a specific battery voltage.

Whilst this operation is fine for charging the engine battery, the charging voltage and current output of the alternator provides challenges to enable effective split charge of an auxiliary battery.

Use of traditional split charging devices (e.g. Voltage Sensitive Relays) will result in insufficient charge being applied to the auxiliary battery. Continued use of this battery will result in deeply discharged or damaged auxiliary batteries.

OneBox 75 uses a combination of strategies to overcome these issues.

During periods when normal charging is taking place to the engine battery (e.g. during vehicle coasting or braking), OneBox 75 uses a battery paralleling contactor. This allows a very high charge current into the auxiliary battery.

During the periods where the EMS is maintaining a specific engine battery voltage, the OneBox 75 utilises the internal DC-DC converter. This takes the engine battery voltage and converts it to a pre-set charge voltage which is applied to the auxiliary battery, at a maximum continuous charge current of 75A.

The DC-DC converter is limited in current, voltage and thermal capability to ensure that correct operation and damage does not occur to either the engine battery, auxiliary battery or the OneBox 75 itself.

Once the OneBox 75 is configured and installed within the vehicle platform, the device will cycle between the different charge cycles automatically. The only indication that this is happening may be the occasional 'clunk' heard when the internal contactors cycle or feedback via the external status LEDs.

User control and feedback can be provided via switches and LEDs as detailed within the 'Programming' section of this document. However, the device will work without these if user intervention is not preferred.

Additional configuration of the device can take place within the programming to control when auxiliary battery charging should take place or to inhibit activation of the engine flat battery protection (i.e. when the vehicle ignition is 'On').

The OneBox 75 can also be configured to use the external contactor as a 'load shed' device on the auxiliary battery.

The OneBox 75 is J1939 CAN enabled and can be used to broadcast battery information / status to the vehicle CAN system. It can also use Vehicle CAN information (e.g. Engine Run Signal) to control unit operation.

## After Installation

If you are unsure about any aspect please consult a suitably qualified engineer, your Dealer or Merlin Equipment Ltd before commissioning the unit.

## Product Specifications

<b>OneBox 75 ECU</b>	
Part Number	04-8720
ECU Maximum Dimensions excluding cabling (W x L x H)	202 x 323 x 100mm
ECU Weight excluding cabling	4.75Kg
Voltage Rating	Nominal 12.6V DC
Operational Input Voltage Range	8.0 to 16V DC
DC-DC Converter Operation Input Voltage (limited output capability at 11 to 12V input [1])	11.0 to 16.0V DC
DC-DC Converter Operation Input Voltage (with full output current capability [2])	12.0 to 16.0V DC
DC-DC Converter Maximum Input Current [3]	100A
Maximum Output Current (DC-DC Converter mode)	75A
Storage Temperature	-25 to + 85°C
Full Operation Temperature Range (°C)	-25 to + 35° (see converter temp. range)
Operation Temperature Range with Limited DC-DC Converter Output	-25 to +70°C
Maximum Output Current (parallel mode):	200A Continuous, 350A Peak
Maximum Continuous Output @ Ambient Temperature	20°C: 70A 25°C: 65A 30°C: 58A 35°C: 50A
Standby Current Consumption	Hibernate Mode 8mA* Sleep Mode 11mA* Idle Mode 21mA* *Average without LEDs connected at 12.8V DC
Maximum number of Battery Banks	2
Voltage Reading Range	0 to 19.3V
Voltage Reading Accuracy	0.3% +/- 1 LSd
Current Measurement Range (DC Converter Only)	0 to 100A
Accuracy (+/-)	5%
LED Output	5V DC Source with 1K series limiting resistor
PC Communications	USB Type B Socket
CAN Communications	J1939 CAN Enabled

[1] Software forces the LV Limit to operate below 12.0V input to limit the maximum input current. This means at an 11.0V input, the max output will actually be 0A. At 11.5V input, the maximum output will be 50% of the user set current limit.

[2] Assuming LV Limit is not enabled.

[3] Regardless of software settings, this is a hardware limit which will prevent the DC converter ever drawing more than this current.

[4] All specifications subject to change without prior notice

## DC-DC Converter Efficiency Graph

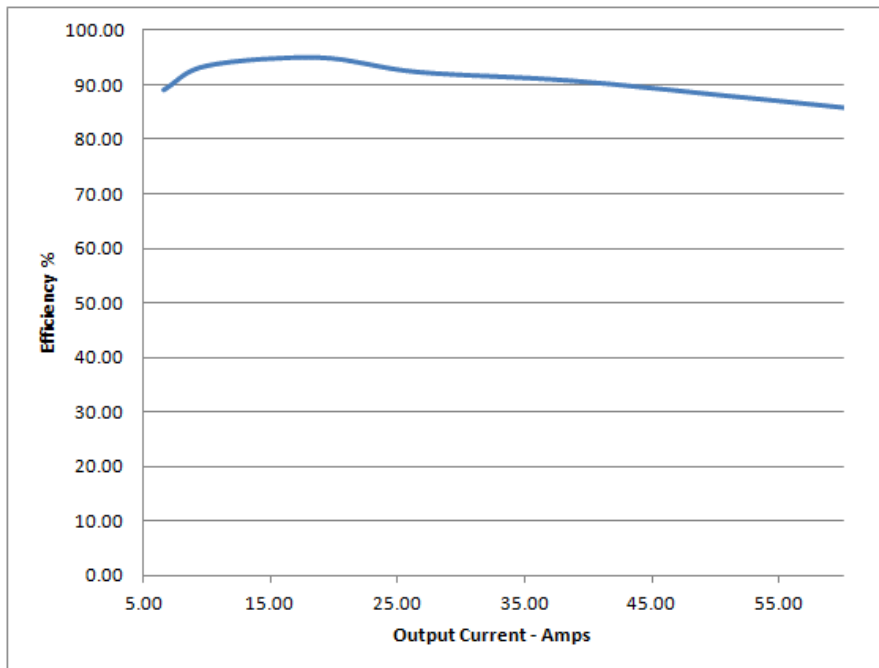

Measurements carried out at 25°C ambient, nominal 13V DC input voltage

## Torque Settings

Fixing Description	Torque Settings
M8 Positive Cable Connection Studs	8.0 – 9.5Nm
M8 Ground Stud (GND)	8.0 – 9.5Nm
M5 Earth Stud	4-5Nm

## Product Accessories

Merlin Part Number	Description
19-5010	Flat Battery / Isolator Contactor
19-5018	Input Switch (On)-Off Momentary with Red LED
19-5019	Input Switch (On)-Off Momentary with Green LED
10-4012	Cable Cap Insulation Boot 2 – 2/0 AWG Red
10-4013	Cable Cap Insulation Boot 2 – 2/0 AWG Black
HWC/FHMG/1	Mega Fuse Holder
HWC/FME/200	200A Mega Fuse
HWC/ATOF/KIT	ATO Single Blade Fuse Holder
HWC/BF2	2 Amp Blade Fuse
04-8810	OneBox GP I/O Loom – 2m
04-8811	OneBox GP I/O Loom – 5m
04-8820	OneBox J1939 CAN Connection Loom – 2m

## **Warranty**

OneBox 75 is warranted to be free of defects caused during manufacture for a period of 2 years from purchase. The warranty may be invalidated if the device has been altered, misused, installed incorrectly or operated in adverse conditions described in the “Precautions” section of this document.

**What does this warranty cover and how long does it last?** This Limited Warranty is provided by Merlin Equipment Limited. (“Merlin”) and covers defects in workmanship and materials in your OneBox 75. This warranty period lasts for 24 months from the date of purchase at the point of sale to you, the original end user customer, unless otherwise agreed in writing (the “Warranty Period”). You will be required to demonstrate proof of purchase to make warranty claims.

This Limited Warranty is transferable to subsequent owners but only for the unexpired portion of the Warranty Period. Subsequent owners also require original proof of purchase as described in “What proof of purchase is required?”

**What will Merlin do?** During the Warranty Period Merlin will, at its option, repair the product (if economically feasible) or replace the defective product free of charge, provided that you notify Merlin of the product defect within the Warranty Period, and provided that Merlin through inspection establishes the existence of such a defect and that it is covered by this Limited Warranty.

Merlin will, at its option, use new and/or reconditioned parts in performing warranty repair and building replacement products. Merlin reserves the right to use parts or products of original or improved design in the repair or replacement. If Merlin repairs or replaces a product, its warranty continues for the remaining portion of the original Warranty.

Period or 90 days from the date of the return shipment to the customer, whichever is greater. All replaced products and all parts removed from repaired products become the property of Merlin.

Merlin covers both parts and labour necessary to repair the product, and return shipment to the customer via a Merlin-selected non-expedited surface freight within the contiguous United States and Canada. Alaska, Hawaii and outside of the United States and Canada are excluded. In Europe, this is the EMEA. Contact Merlin Customer Service for details on freight policy for return shipments from excluded areas.

**How do you get service?** If your product requires troubleshooting or warranty service, contact your merchant. If you are unable to contact your merchant, or the merchant is unable to provide service, contact Merlin directly at: Merlin Equipment Ltd, Clyst Court, Hill Barton Industrial Estate, Exeter, Devon, EX5 1SA, United Kingdom. Tel: +44 (0) 1202 697979.