

JMP INSTRUCTIONALS:

HOW TO INSTALL A WALL RAIL: BRACKET 3002

SUPPLIES:



HANDRAIL BRACKET 3002



Stanley 16 OZ. FIBERGLASS HAMMER

Colored Black(Best For Black Hardware)



Alternative(For All Hardware)



E6100 Pro-Grade Industrial Adhesive or Titebond Fast Set AND CAULKING GUN



STANLEY FATMAX CLASSIC TAPE MEASURE



TITEBOND II PREMIUM INTERIOR & EXTERIOR WOOD GLUE



G-FORCE ALUMINUM ALLOY RAFTER SQUARE

"COME GET YA STAIR PARTS!"

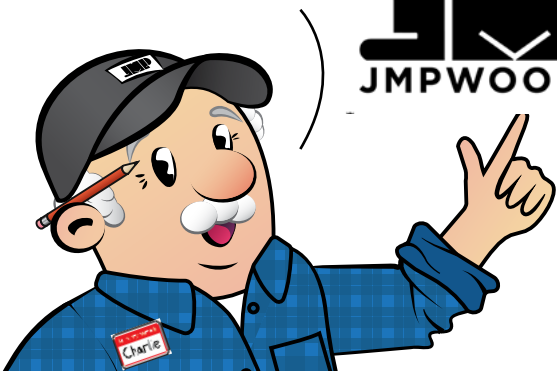

FAMOWOOD LATEX WOOD FILLER



IRWIN STRAIT-LINE CHALK REEL-100'

JMP INSTRUCTIONALS:

HOW TO INSTALL A WALL RAIL: BRACKET 3002

1

MEASURE AND MARK:

MEASURE 31-3/8" UP FROM THE NOSING OF THE BOTTOM AND TOP TREAD AND MARK A POINT WITH A PENCIL.

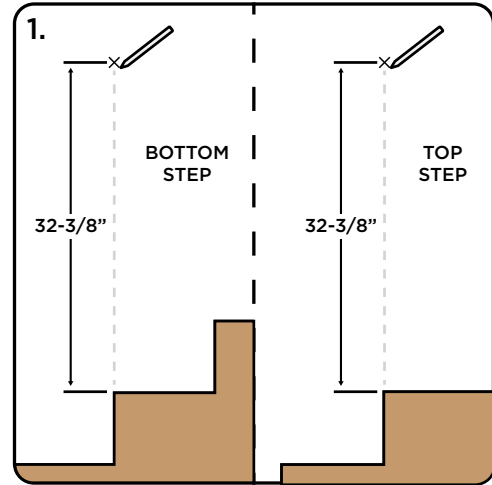

2

TAP IN A NAIL:

TAP IN A NAIL AT THE MARK LOCATED AT THE BOTTOM OF THE STAIR.

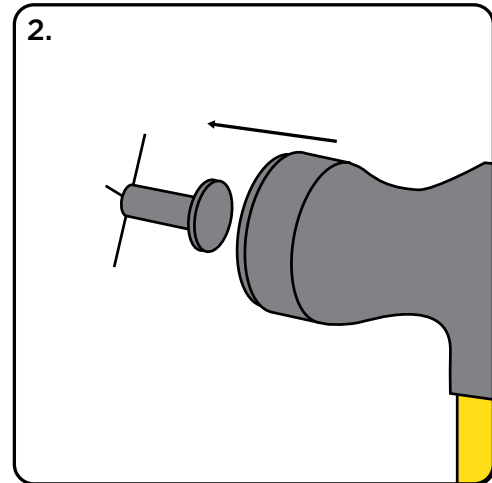

3

MARK A LINE:

HOOK THE [IRWIN STRAIT-LINE CHALK REEL](#) TO THE NAIL AND ALIGN IT TO THE MARK AT THE TOP OF THE STAIRS.

KEEPING THE LINE TAUT, SNAP THE LINE AGAINST THE WALL SO THAT IT CREATES A DISTINCT MARK ALONG THE RUN OF THE STAIRS.

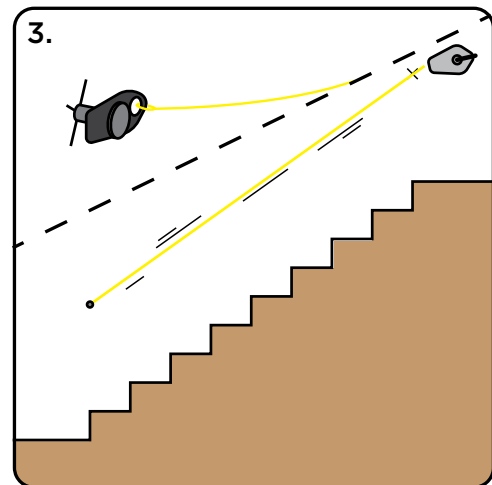

JMP INSTRUCTIONALS:

HOW TO INSTALL A WALL RAIL: BRACKET 3002

4

LOCATE THE STUDS AND MARK:

USING A STUD FINDER, LOCATE STUDS WHERE YOU WOULD LIKE TO POSITION YOUR HANDRAIL BRACKETS.

PLACE MARKS WHERE THE LINE CREATED IN STEP 3 AND THE MIDDLE OF THE STUDS INTERSECT.

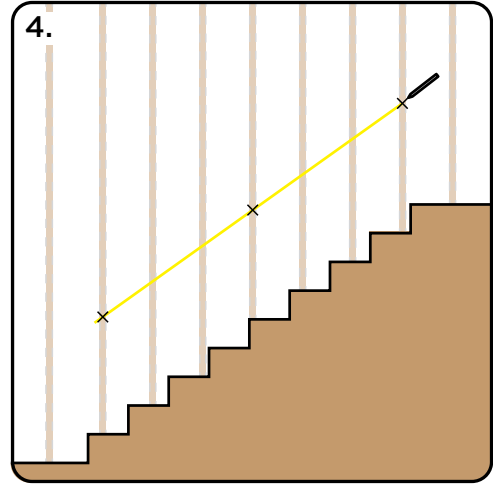

5

INSTALL BRACKETS AT THE MARKED POSITIONS:

ALIGN THE CENTER OF THE BOTTOM-MOST HOLE OF THE BRACKET TO THE POINTS CREATED IN STEP FOUR.

SCREW IN THE BOTTOM SCREW FIRST, ROTATE THE BRACKET SO THAT IT IS VERTICAL, AND SCREW IN THE REST.

BE SURE YOU ARE USING THE 3 LONGER SCREWS INCLUDED WITH THE BRACKET.

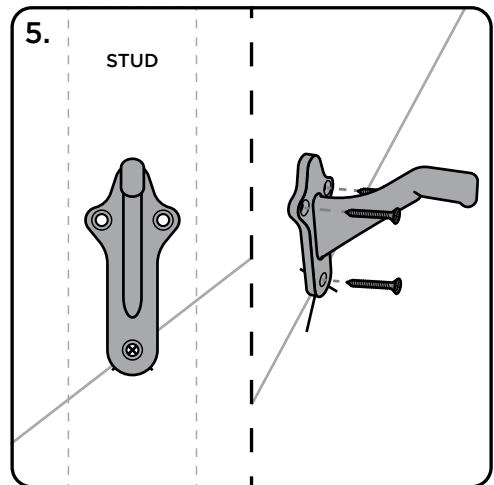

6

MEASURE:

MEASURE AS DEPICTED.

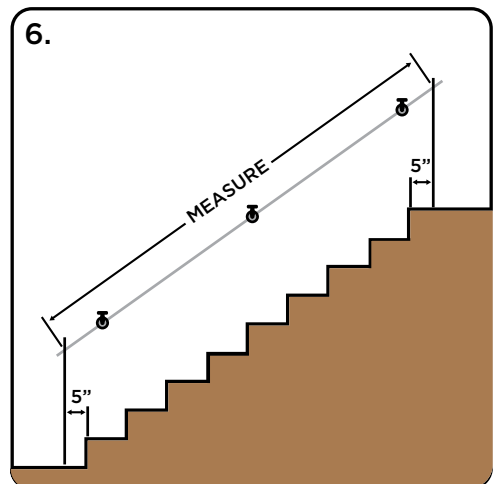

JMP INSTRUCTIONALS:

HOW TO INSTALL A WALL RAIL: BRACKET 3002

7

MEASURE AND CUT RAIL AT A 45° ANGLE:

TAKE THE MEASUREMENT CREATED IN STEP 6 AND CUT YOUR RAIL SLIGHTLY OVERSIZED AT A 45° ANGLE ON A MITER SAW.

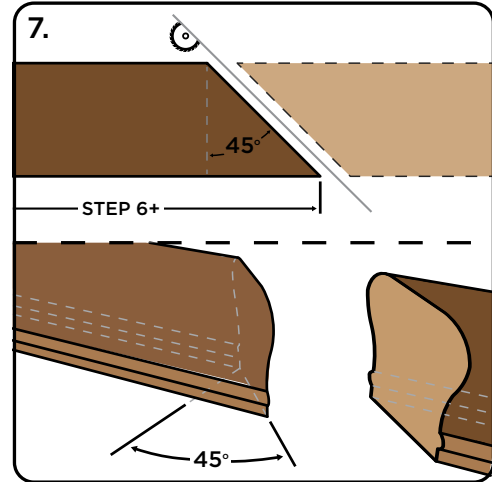

8

CUT OTHER SIDE:

NEXT, CUT THE OTHER END OF THE RAIL AT THE EXACT LENGTH RECORDED IN STEP 6 WITH A REVERSE 45° ANGLE.

RESERVE THE REMAINING RAIL FOR STEP 9.

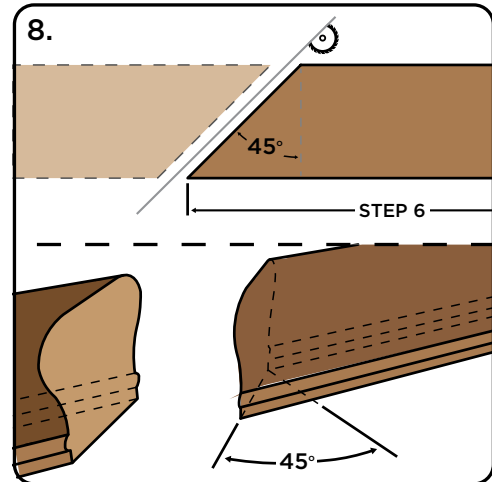

9

CUT ADJOINING MITERS:

USING THE SCRAP COMPLETE THE FOLLOWING STEPS.

CUT A 45° ANGLE, MEASURE 1-1/2" FROM THE INSIDE AND CUT AT A 90° ANGLE.

CUT A REVERSE 45° ANGLE, MEASURE 1-1/2" FROM THE INSIDE AND CUT AT A 90° ANGLE.

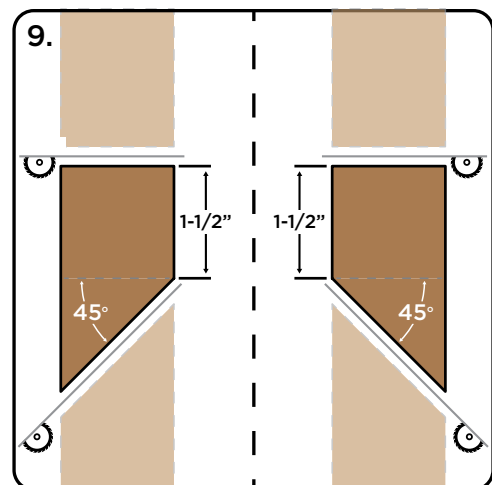

JMP INSTRUCTIONALS:

HOW TO INSTALL A WALL RAIL: BRACKET 3002

10

ATTACH THE MITERS:

USING OUR [TITEBOND II PREMIUM INTERIOR & EXTERIOR WOOD GLUE](#), APPLY SOME ADHESIVE TO THE JOINING FACES AND SECURE WITH THE USE OF A [NAIL GUN](#).

WE RECOMMEND USING PIN-NAILS.

SAND RAIL AND FILL THE HOLES WITH SOME FAMOWOOD LATEX WOOD FILLER.

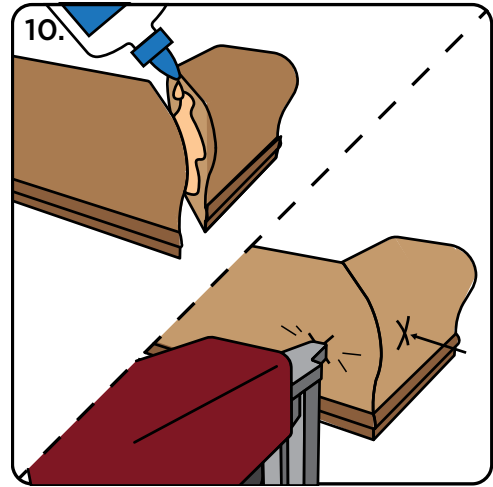

11

SET RAIL ON BRACKETS:

WITH THE HELP OF A PARTNER, SET THE MITERED RAIL ON THE RAIL BRACKETS SO THAT IT IS POSITIONED EVENLY WITH THE STAIRS.

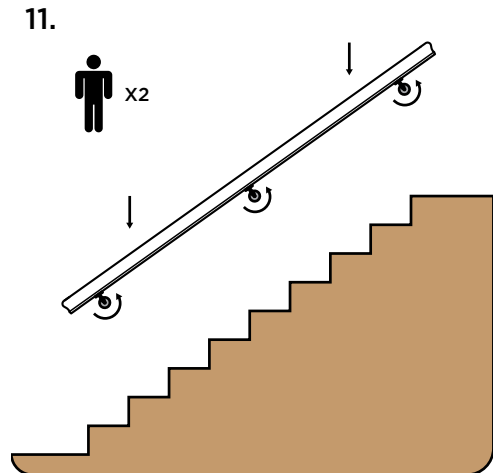

12

MARK WHERE THE RAIL INTERACTS WITH THE WALL:

STARTING AT THE TOP OF THE STAIRS, USE A PENCIL TO MARK THE PROFILE OF THE RAIL.

REMOVE THE RAIL FROM THE BRACKETS.

APPLY SOME [LOCTITE PL PREMIUM POLYURETHANE CONSTRUCTION ADHESIVE](#) TO THE WALL WITHIN THE OUTLINE.

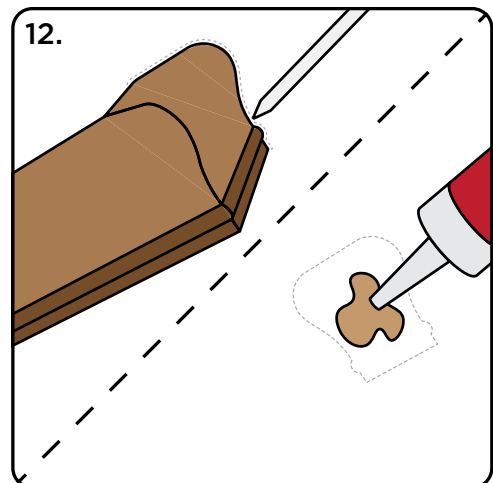

13

ATTACH THE TOP OF THE RAIL TO THE WALL:

USING SOME FORCE, ADHERE THE RAIL TO THE WALL, MAKING SURE THE RAIL IS ALIGNED TO THE PROFILE DRAWN IN [STEP 12](#)

USING A NAIL GUN, SHOOT A COUPLE OF PIN-NAILS IN THE HANDRAIL SO THAT IT HOLDS IT TO THE WALL.

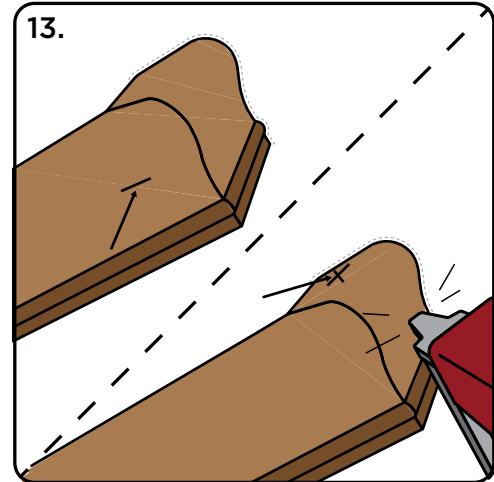

14

ATTACH BOTTOM OF THE RAIL TO THE WALL:

FOR THE BOTTOM END OF THE RAIL, CAREFULLY PULL THE RAIL AWAY FROM THE WALL ENOUGH SO THAT YOU CAN INJECT SOME CONSTRUCTION ADHESIVE AND ADHERE THE RAIL TO THE WALL WITH SOME FORCE.

SECURE WITH PIN NAILS. APPLY SOME WOOD FILLER AND SAND TO FINISH.

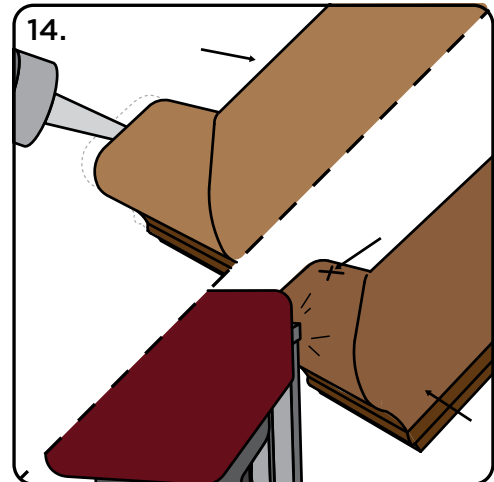

15

SECURE THE RAIL TO THE BRACKETS:

FINALLY, SCREW THE HANDRAIL CONNECTOR TO SECURE THE RAIL TO THE BRACKETS.

MAKE SURE THAT THE RAIL IS CENTERED ON THE BRACKET.

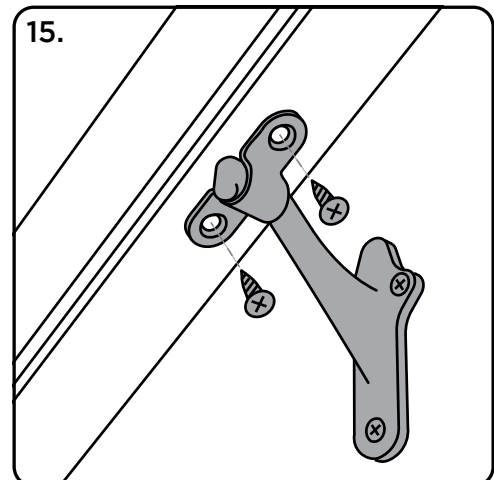



NOTICE: FAILURE TO PROPERLY SECURE THE HANDRAIL IS DANGEROUS.

IT IS IMPERATIVE THAT THE RAIL IS SECURED TO WALL STUDS AND RAIL BRACKETS. IMPROPER MOUNTING CAN RESULT IN DEATH OR INJURY.



NOTICE



Important Note: Consumer Self-Installation

Please note that you if have chosen to install the product yourself. It is crucial to emphasize that you, as the consumer, are solely responsible for the installation process. We highly recommend adhering to your local building codes, regulations, and guidelines while installing our product. Local codes vary, and it is your responsibility to comply with them to guarantee a safe and secure installation.

JMPWood Disclaimer:

JMPWood assumes no liability for any risks, damages, or issues that may arise due to improper installation. Our installation guide is provided as a reference, but it is not a substitute for professional installation services. If you are unsure about any step of the installation process, we strongly recommend consulting a qualified professional or contractor.

