

INTERNAL HALYARD FOUNDATION INSTALLATION INSTRUCTIONS

1. Dig foundation hole four to six times the butt diameter of the flagpole.
2. Set the foundation tube so that the top of the foundation tube is two inches above grade.
3. Plumb foundation tube and brace so that it will not move during the pouring of the concrete.
4. Pour concrete and trowel up even with top of foundation tube. Keep inside of foundation tube dry.
5. Lay pole on sawhorses and unwrap. For sectional poles check both ends for any burrs. If any are found, file them off and wipe the areas clean. Liquid Soap the jamb sleeves. Align the arrows and/or numbers on each section and jamb together. Numbers must be identical for a proper fit.
6. Turn to the next page for winch and cable assembly.
7. Screw ball into truck and tighten ball set screw. Ball should be tightened into truck tightly by turning stem of ball with wrench. Do not tighten by turning ball proper. Ball optional on internal halyard poles.
8. If flash collar is provided with pole, slide collar on from the bottom of pole to above winch level and attach flash collar by tying to the pole with line to hold flash collar until after erection of pole. Then remove line, slide collar down, caulk between the collar and the pole with waterproof sealant (like roofing cement or asphaltum sealant).
9. Erect pole into foundation tube and center it. Turn so that the access door is in the direction desired.
10. Place wood wedges (supplied by others) between the pole and the foundation tube and plumb pole.
11. Pack dry sand between the pole and foundation tube. Leave two inches void at the top and fill with waterproof sealant to keep water out of the sand.

IMPORTANT:

When erecting sectional flagpoles, never place your sling above the joint. Sling must be positioned below the joint, thus eliminating the possibility that the two sections could separate during hoisting.

CAUTION

Extreme caution should be exercised when installing flagpoles near overhead power lines or in the vicinity of buried cables.

ACCESSORY ASSEMBLY INSTRUCTIONS

1. For ease of assembly, the upper and lower cable assemblies have been pre-assembled at our factory.
2. Locate truck with factory installed cable assemblies (See Illustration #1).
3. Locate lower cable assembly; this will be the cable exiting from the threaded portion of the truck (See Illustration #1).
4. Using an electrical "FISH TAPE" feed lower cable assembly through the 1-1/2" threaded hole at the top of the flagpole, pull lower cable through entire length of flagpole.
5. A winch hole with a slotted keyway will be found about 4 ft. above grade from the bottom of the pole. Using extreme caution, reach into this hole, grasp cable and pull about 4 ft. of cable through this hole (See Illustration #2). **USE CAUTION, THE EDGES OF THIS HOLE MAY BE SHARP!**
6. You should now have all but a few inches of the lower cable assembly inside of the flagpole, or at the lower end of the flagpole. If this is not the case, then repeat steps 1 thru 5.
7. Screw the truck assembly into the top of the flagpole securely.
8. If steps 1 thru 7 have been satisfactorily completed, then you are now ready to install the WINCH ASSEMBLY.
9. Locate the winch assembly. Remove the cylinder lock keys which are taped to the side of the winch assembly. Remove the hex drive countersunk stainless steel screw from the rear of the winch. Put keys and screw in a safe location. You will have to use them in a later step.
10. To remove the lock from winch, insert key, turn counter-clockwise and pull until the cylinder comes out.
11. Locate cable retaining hole and cable retaining set screw (See Illustration #3). With painted surface of winch in left hand and unpainted surface in your right hand, look into window of winch. You will see a 1/8" hole located on right side of the winch drum. This is the cable retaining hole.
12. Take loose end of cable that is protruding from the winch hole and insert into the cable retaining hole. At this point it is important not to expose any cable on the other side of the drum (See Illustration #3).
13. Locate crank handle. Insert into recess and push in and turn clockwise until cable retaining set screw is exposed.
14. Using appropriate size, align wrench and tighten set screw securely (See Illustration #3).
15. Using a square keyway as a pathway for the 1/8" cable, insert the cartridge into the winch hole (See Illustration #4).
16. Locate 1/2" hole which is directly opposite the winch hole. Align this hole with the hole in the cartridge, insert screw and tighten securely (See Illustration #5).
17. With cartridge winch properly installed, insert crank into crank socket. Push in and turn CLOCKWISE until the upper cable starts to move toward the top of the flagpole.
18. Locate the rubber coated counterweight and attach temporarily to open chain link at loose end of the upper cable.

ILLUSTRATION #1

Secure optional finial here

Truck Assembly

Upper Cable Assembly

Lower Cable Assembly

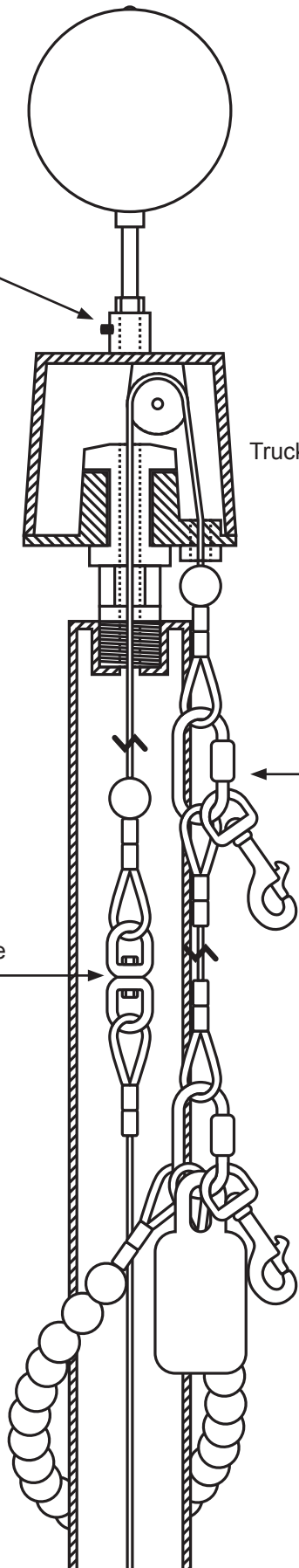

ILLUSTRATION #2

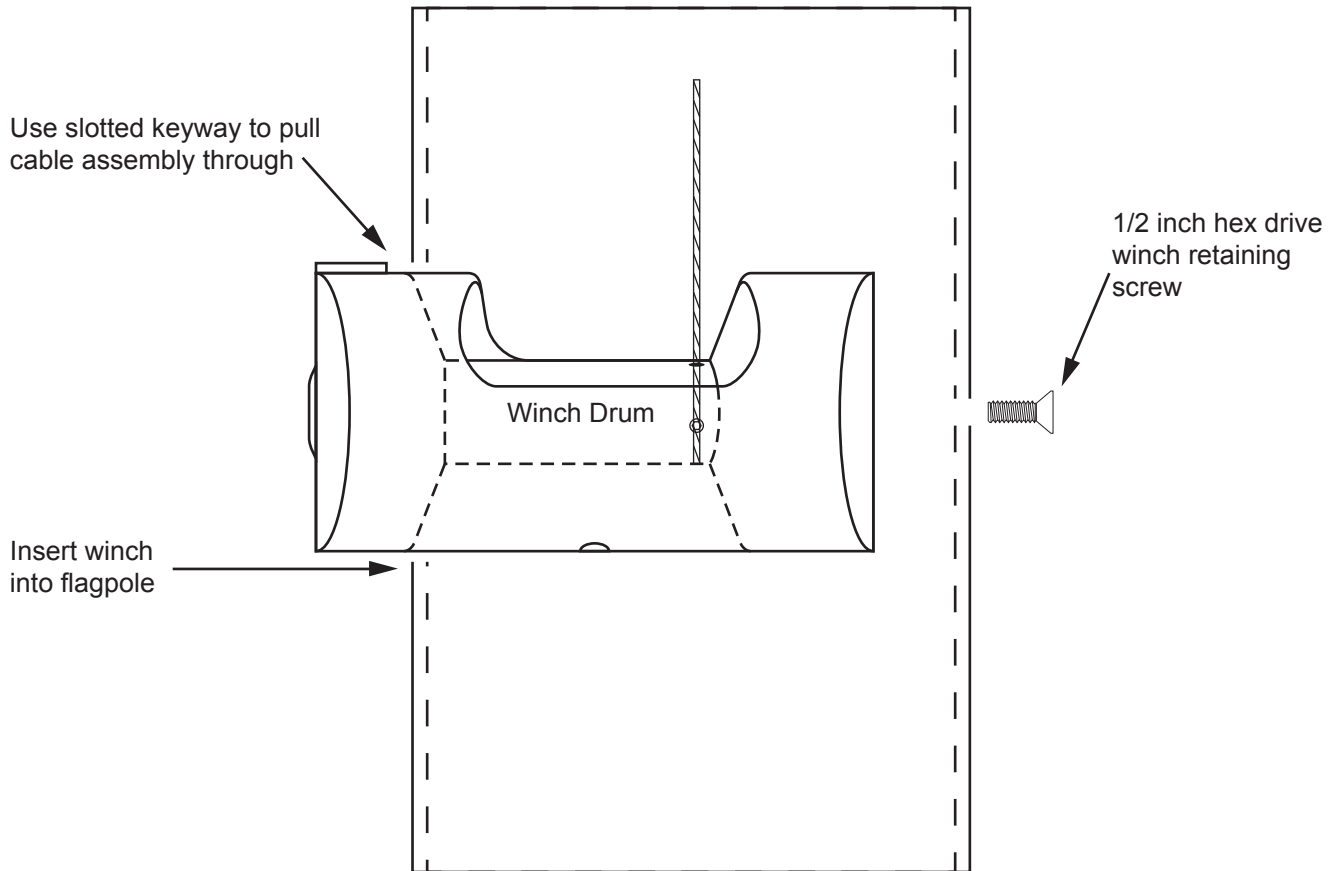

ILLUSTRATION #3

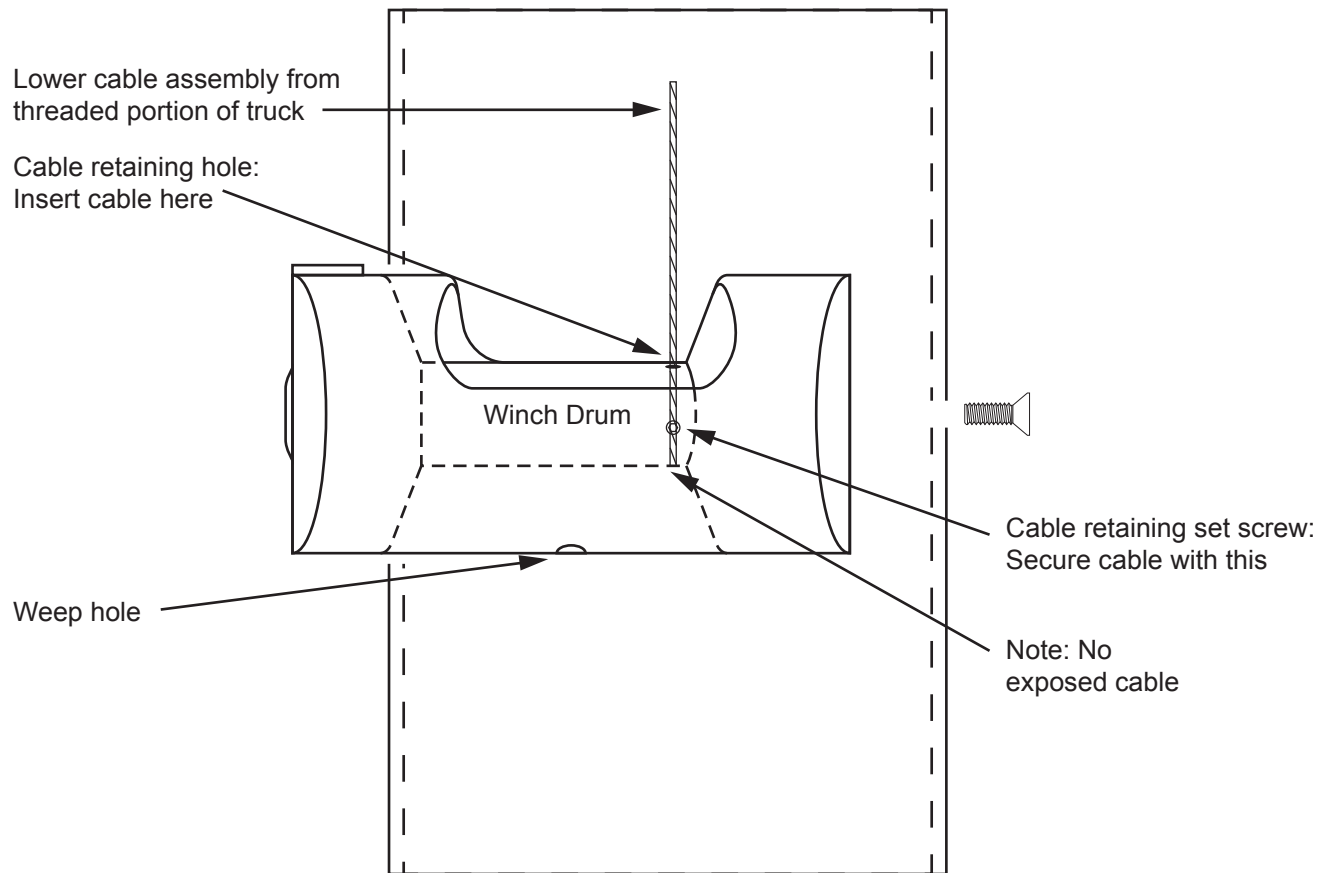
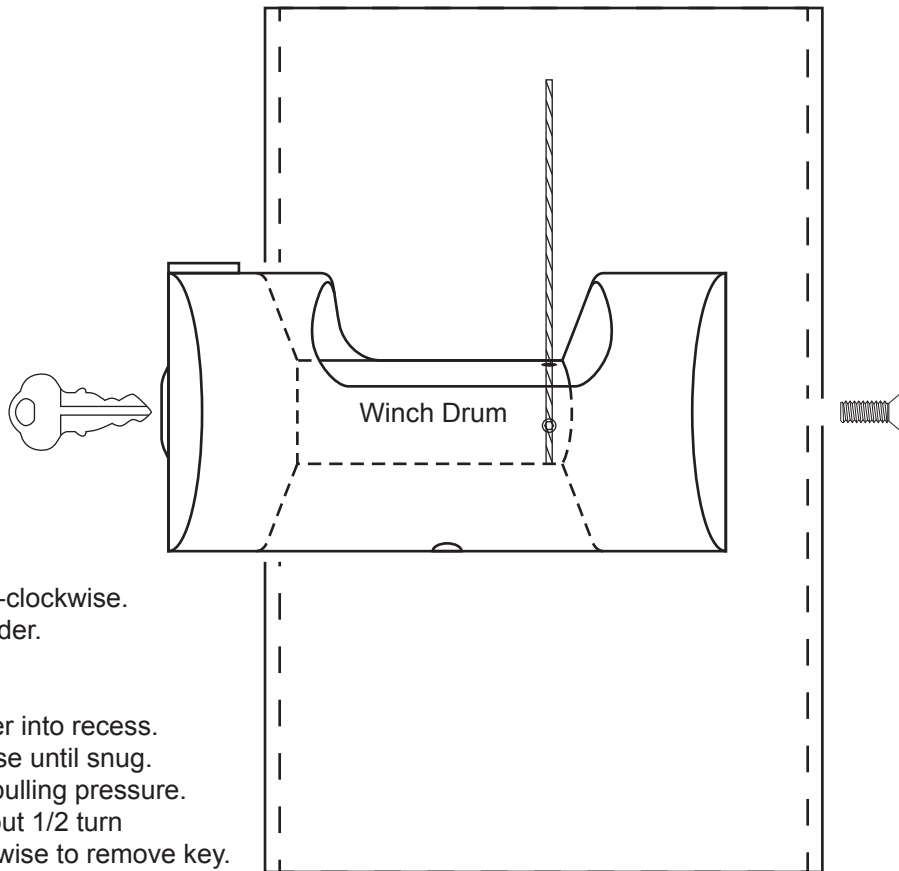

ILLUSTRATION #4



To unlock:

- Insert key.
- Turn counter-clockwise.
- Pull out cylinder.

To lock:

- Insert cylinder into recess.
- Turn clockwise until snug.
- Apply slight pulling pressure.
- Turn key about 1/2 turn counterclockwise to remove key.

ILLUSTRATION #5

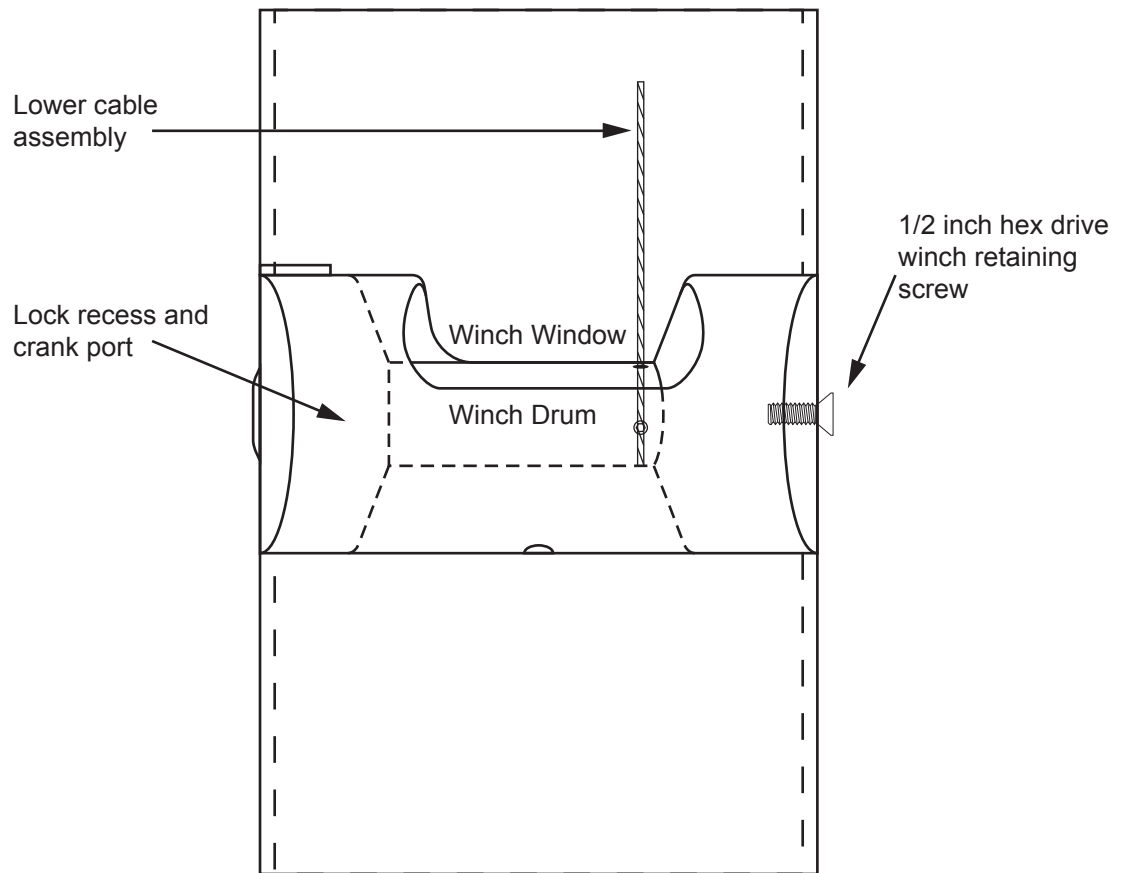

ILLUSTRATION #6

STANDARD FLAG ARRANGEMENT

DELUXE FLAG ARRANGEMENT

