

# AMBIUS SENSOR RANGE

## SPECIFICATION SHEET

Product Code: ASECPRTLTL

Pronto Code: Q5080920

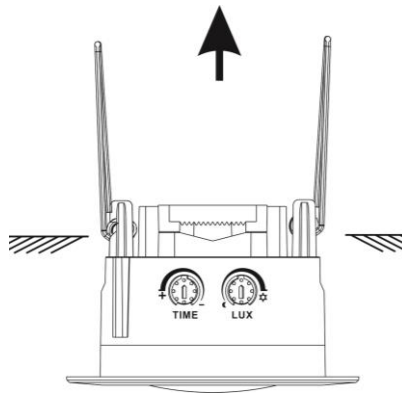

Detection Range

Detection Range maximum of 8m.



Detection Angle

Detection angle of 360 degrees from point of sensor application.



Ingress Protection

Rated IP20, allowing for installation in an indoor area.



Lux Adjustment

Ambient light: 10-2000LUX which is adjustable. Use Sun and LUX dials to choose sensor options.



Max 300W LED

Rated load: 1200W Max. (incandescent lamp) 300W Max. (energy-saving lamp).



Time On Adjustment

Time adjustment: Min: 10sec±3sec Max: 7min±2min

## TECHNICAL SPECIFICATIONS

- 220-240V 50/60Hz
- 300W Max.
- IP20
- 360° Detection range, 8m detection distance.
- Time adjustment: 10sec 15min
- Manual Override Function
- 1-Year warranty
- Cut out between 65-72mm

## INSTALLATION:

- Fold the metal spring of the sensor, until they match the line drawing above.
- Put the sensor into the cutout in the wall/ceiling.
- Release the spring and push the sensor up until it is firmly in place and the springs will hold product in place.

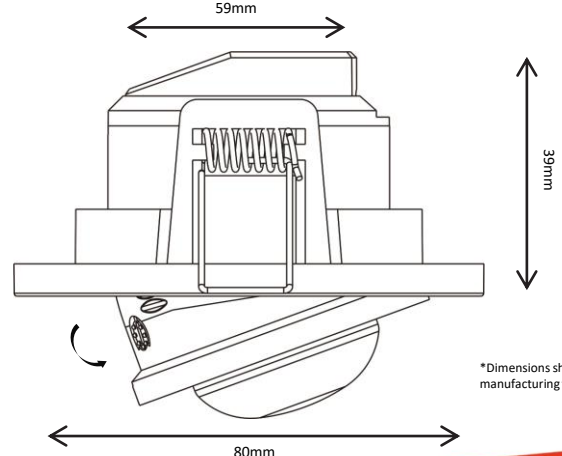

\*Dimensions shown are subject to manufacturing tolerance.

Distributed by:

**CDB** GROUP

PO Box 100-707  
North Shore Mail Centre  
Auckland

Manufactured to Ambius Lighting's specifications in the PRC.