

AMBIUS SENSOR RANGE

SPECIFICATION SHEET

Product Code: ASECPIRMINI

Pronto Code: Q5080930



Detection Range

Detection Range maximum of 6m.



Detection Angle

Detection angle of 360 degrees from point of sensor application.



Ingress Protection

Rated IP20, allowing for installation in an indoor area.



Lux Adjustment

Ambient light: 10-2000LUX which is adjustable. Use Sun and LUX dials to choose sensor options.



Max 800W LED

Rated load:
800W Max. (incandescent lamp) &
400W Max. (energy-saving lamp).



Time On Adjustment

Time adjustment:
Min: 10sec±7sec
Max: 7min±3min

TECHNICAL SPECIFICATIONS

- 220-240V 50~60Hz.
- 800W Max.
- IP20.
- 360° Detection range, 6m detection distance.
- Cut out 40mm.
- Manual Override Function

INSTALLATION:

- Loosen the base (with a flat screwdriver on the side), open the wiring cavity, feed the mains supply through the base.
- Connect the power and load wire into connection-wire column according to the connecting figure.
- Fix the base with supplied screws to the wall, then clip sensor onto base plate.
- Put the sensor on the base, twist the screw tightly then liven and test it.

Step 1:

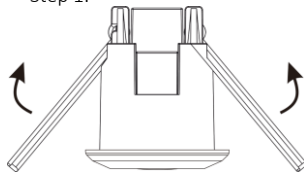

Step 2:

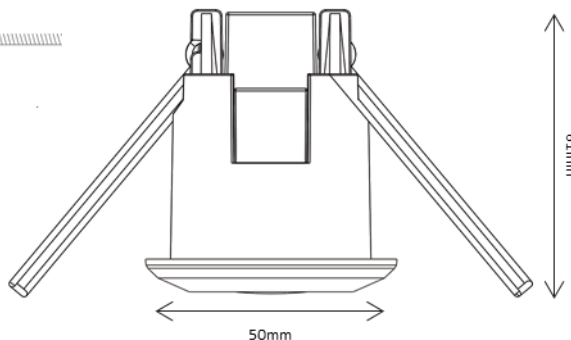
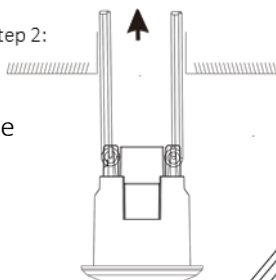

*Dimensions shown are subject to manufacturing tolerance.

Distributed by:

CDB

GROUP

PO Box 100-707
North Shore Mail Centre
Auckland

Manufactured to Ambius Lighting's specifications in the PRC.