

# AMBIUS SENSOR RANGE

## SPECIFICATION SHEET

Product Code: ASECPIRIP65

Pronto Code: Q5080950



Detection Range

Detection Range maximum of 8m.



Detection Angle

Detection angle of 360 degrees from point of sensor application.



Ingress Protection

Rated IP65, allowing for installation in a covered outdoor area.



Lux Adjustment

Ambient light: 10-2000LUX which is adjustable. Use Sun and LUX dials to choose sensor options.



Max 300W LED

Rated load:  
1200W Max. (incandescent lamp)  
300W Max. (energy-saving lamp).



Time On Adjustment

Time adjustment:  
Min: 10sec±3sec  
Max: 7min±2min

## TECHNICAL SPECIFICATIONS

- 220-240V 50/60Hz
- Maximum Load:
  - 300W LED
  - 1200W Incandescent
- IP65
- 360° Detection range, 8m detection distance.
- Time adjustment: 10sec 15min
- Manual Override Function
- 1-Year warranty
- Cut out between 62-72mm

Step 1:

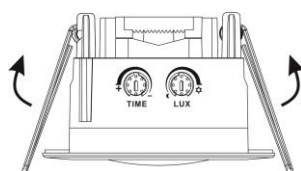

Step 2:

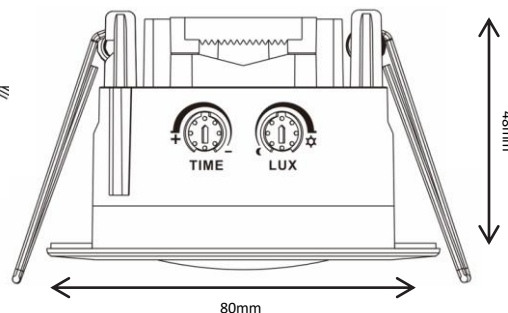
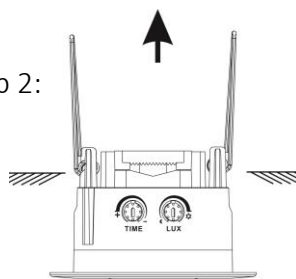

## INSTALLATION:

- Fold the metal spring of the sensor, until they match the line drawing above.
- Put the sensor into the cutout in the wall/ceiling.
- Release the spring and push the sensor up until it is firmly in place and the springs will hold product in place.

\*Dimensions shown are subject to manufacturing tolerance.

Distributed by:

**CDB**

GROUP

PO Box 100-707  
North Shore Mail Centre  
Auckland

Manufactured to Ambius Lighting's specifications in the PRC.