

# "CARRIER"



DEVELOPMENT

1990 OLIVERA RD SUITE B  
CONCORD, CA 94520

[www.TNHDev.com](http://www.TNHDev.com)

PHONE: 800-916-1503

**PROPRIETARY AND CONFIDENTIAL**

THE INFORMATION CONTAINED IN THIS DRAWING IS THE SOLE PROPERTY OF TNH DEVELOPMENT, LLC. ANY REPRODUCTION IN PART OR AS A WHOLE WITHOUT THE WRITTEN PERMISSION OF TNH DEVELOPMENT, LLC. IS PROHIBITED.

DATE: DESIGNED: DRAFTER:

REVISIONS		
REV	DATE	DESCRIPTION

"CARRIER"

TITLE SHEET	"SITE NAME" SITE# XXX00000 "JOB DESCRIPTION" "ADDRESS"
-------------	---

# "SITE NAME"

SITE# XXX00000

"JOB DESCRIPTION"

"ADDRESS"

## TABLE OF CONTENTS

T1	TITLE SHEET
N1	NOTES
S1	OVERVIEW
S2	DETAILS
S3	OPTIONAL PARTS

**GENERAL NOTES:**

1. TNH Development, LLC's standard fabrication and manufacturing tolerances & techniques will apply.
2. Anchor bolts and/or attachment hardware by others unless noted.
3. Existing structure and connection shall be verified by others to support the new vertical and lateral loads of the FRP enclosure.
4. The term "integrated" refers to a procedure used in fiberglass applications where two members are bonded to each other with the use of fiber laminates and fiber-glass resin as the bonding agent.
5. Structure is not intended to be a fully weatherproof structure, any weather proofing if required by others.
6. Panels should not be opened in gusty or constant wind exceeding 10 mph. Panels need to be secured when in open position.
7. Fiberglass skin is TNH Development, LLC's 1/4" nominal.
8. Fiberglass skin flexural capacity = 800 lb-in/ ft min.
9. All field cut or drilled edges of FRP structural members to be coated by others with resin or acrylic sealer.
10. If prefabricated members are not assembled per plan, contact TNH Development, LLC before cutting or altering fabricated members.
11. Structural FRP members shall be fabricated and assembled as indicated on the drawings.
12. The contractor shall protect the FRP structural members from abuse to prevent breakage, nicks, gouges, etc. During fabrication, handling, and installation.
13. Antennas & antenna brackets supplied and installed by others unless otherwise noted.
14. Standard finish is factory primer. Final painting by others unless otherwise noted.
15. Steel for all shapes shall comply with ASTM A36 minimum.
16. The words "the engineer" as used in these notes, refer to a representative of TNH Development, LLC.
17. The general contractor shall become familiar with all existing site conditions and with all design documents provided by the various design professionals involved in this project.
18. The general contractor shall verify all dimensions, details and spacial relationships shown on these drawings in conjunction with all other related design drawings. Any discrepancies, conflicts or omissions found shall be reported to the engineer and other design professionals as appropriate for resolution prior to proceeding with any work on the project.
19. All work shall comply with the currently adopted edition of the california building code and all state and local codes and ordinances.
20. Any testing or inspections required by building officials or the project drawings or specifications shall be performed by an approved independent testing laboratory.
21. Observation visits to the site by the engineer shall neither be construed as inspection nor approval of construction.
22. The general contractor is soley responsible for compliance with O.S.H.A. standards.
23. All A.S.T.M. specifications noted on the drawings shall be as amended to date.
24. Details and notes on these plans are typical. Similar requirements apply to similar conditions.
25. These drawings are not final until final approval from all governing agencies is received and a permit has been issued. All quantity, grades and sizes of strucural components may change. Bids/Pricing performed on plans not yet approved and permitted may change and should not be relied upon for budgets or final costs.

**STRUCTURAL STEEL:**

1. All structural steel shall conform to A.S.T.M. A36 unless noted otherwise.
2. Structural steel W sections, shall conform to A.S.T.M. A992 grade 50.
3. Steel pipe columns shall conform to A.S.T.M. A501, Fy=36 Ksi or A.S.T.M. A53, types E or S, grade B, Fy=35 Ksi.
4. Structural tube steel columns shall conform to A.S.T.M. A500, grade B, Fy=46 Ksi.
5. Bolts shall conform to A.S.T.M. A325 unless noted otherwise.
6. Diameter of bolt holes in steel shall be 1/16" larger than the bolt size unless noted otherwise.
7. All welds shall be in conformity with the structural welding code of american welding society (A.W.S.)
8. Anchor bolts shall conform to either A.S.T.M. A325 or A36 unless noted otherwise, and shall be headed bolts or threaded rod with double nuts.
9. Protect all steel columns, base plates, anchor bolts, embedment plates, weld plates, etc. below top of floor slab with a minimum of 3" of concrete cover.
10. Fabrication and erection shall comply with A.I.S.C. specifications for buildings, as revised to date.
11. Steel framing dimensions are to the centerlines of columns and W shapes and to the smooth face of channels.
12. Verify all dimensions with architectural and mechanical drawings. coordinate any conflicts before proceeding.
13. Steel beams shall be placed with mill camber upward.

**DISCLAIMERS:**

All structural components to be connected together shall be completely fit-up on the ground or otherwise verified for compatibility prior to lifting any component into place. Repairs required due fit-up or connection compatibility problems after partial erection are the financial responsibility of the contractor.

**SPECIAL INSPECTIONS:**

1. No field welding shall be permitted except where noted.

**STRUCTURAL OBSERVATION:**

NO STRUCTURAL OBSERVATION IS REQUIRED.

**DESIGN CODE:**

2019 CALIFORNIA BUILDING CODE  
TIA-H-222



**DEVELOPMENT**

1990 OLIVERA RD SUITE B  
CONCORD, CA 94520

[www.TNHDev.com](http://www.TNHDev.com)

PHONE: 800-916-1503

**PROPRIETARY AND CONFIDENTIAL**

THE INFORMATION CONTAINED IN THIS DRAWING IS THE SOLE PROPERTY OF TNH DEVELOPMENT, LLC. ANY REPRODUCTION IN PART OR AS A WHOLE WITHOUT THE WRITTEN PERMISSION OF TNH DEVELOPMENT, LLC. IS PROHIBITED.

DATE: DESIGNED: DRAFTER:

REVISIONS		
REV	DATE	DESCRIPTION

"CARRIER"

NOTES	"SITE NAME"
	SITE# XXX0000 "JOB DESCRIPTION" "ADDRESS"

FRP RADOME (Ø66")

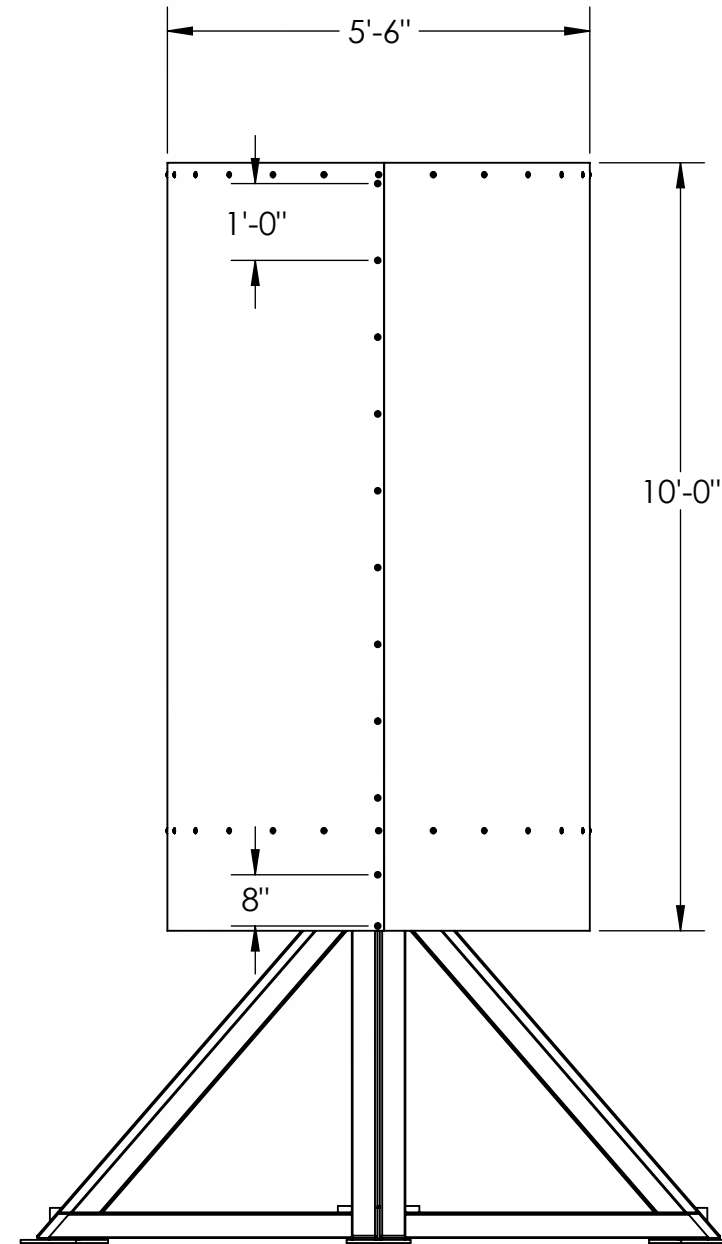
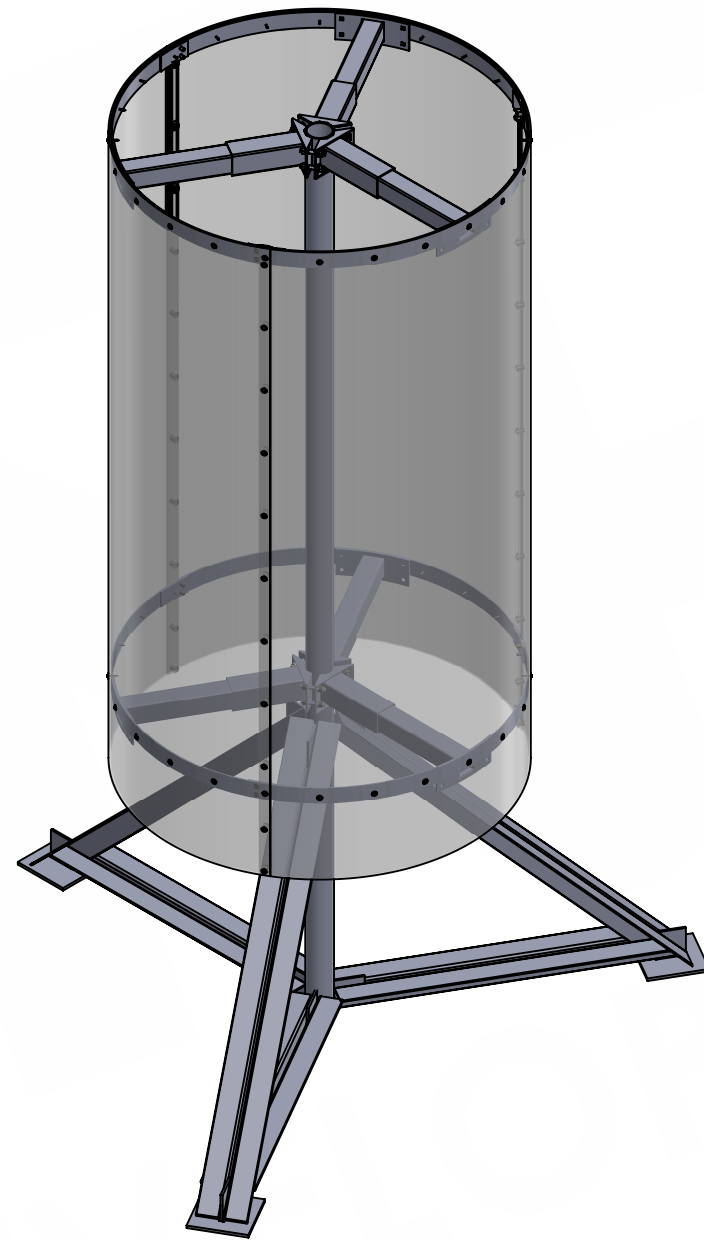
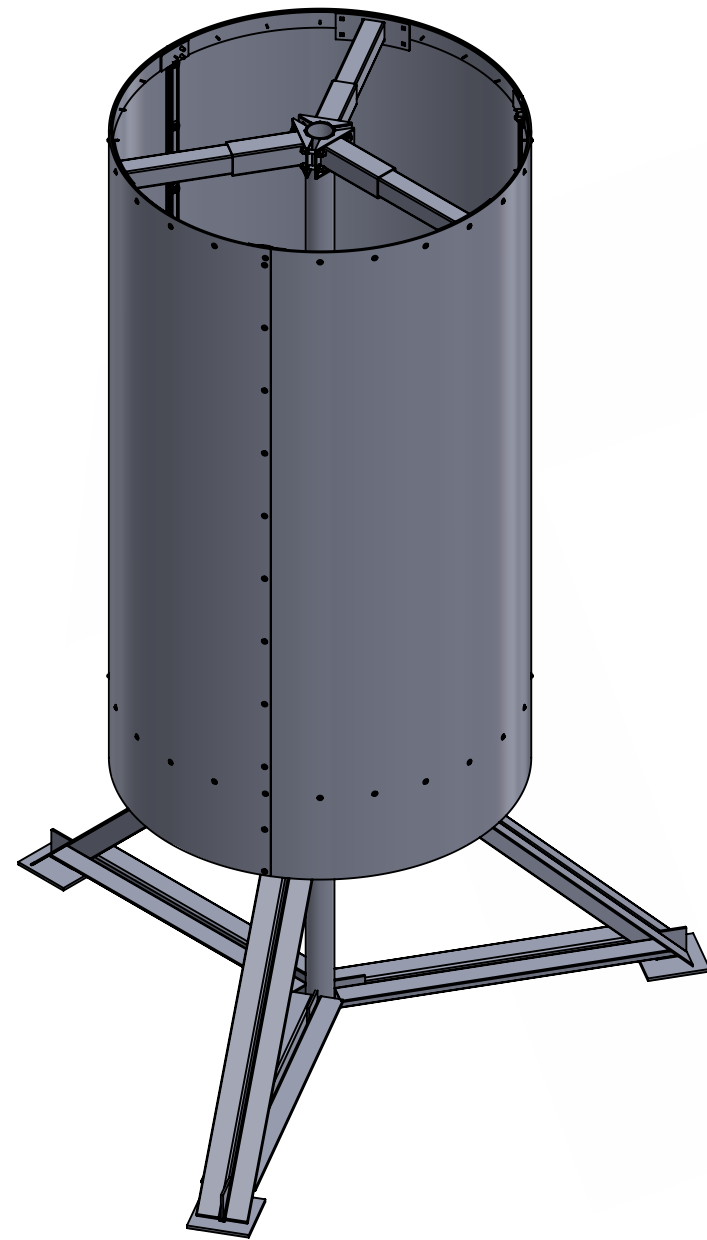

**TNH DEVELOPMENT**

1990 OLIVERA RD SUITE B  
CONCORD, CA 94520

[www.TNHDev.com](http://www.TNHDev.com)

PHONE: 800-916-1503

**PROPRIETARY AND CONFIDENTIAL**

THE INFORMATION CONTAINED IN THIS DRAWING IS THE SOLE PROPERTY OF TNH DEVELOPMENT, LLC. ANY REPRODUCTION IN PART OR AS A WHOLE WITHOUT THE WRITTEN PERMISSION OF TNH DEVELOPMENT, LLC. IS PROHIBITED.

DATE: DESIGNED: DRAFTER:

REVISIONS	
REV	DESCRIPTION

"CARRIER"

OVERVIEW	"SITE NAME"
	SITE# XXXXXXXX "JOB DESCRIPTION" "ADDRESS"

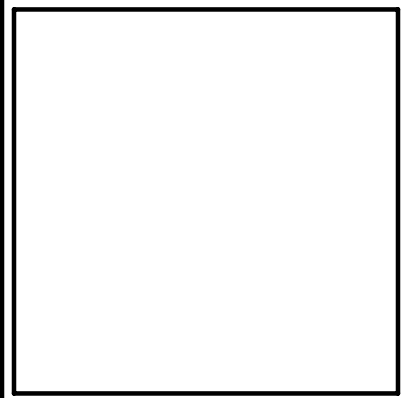

S1	REV
	A
SHEET 3	

FRP RADOME (Ø66")

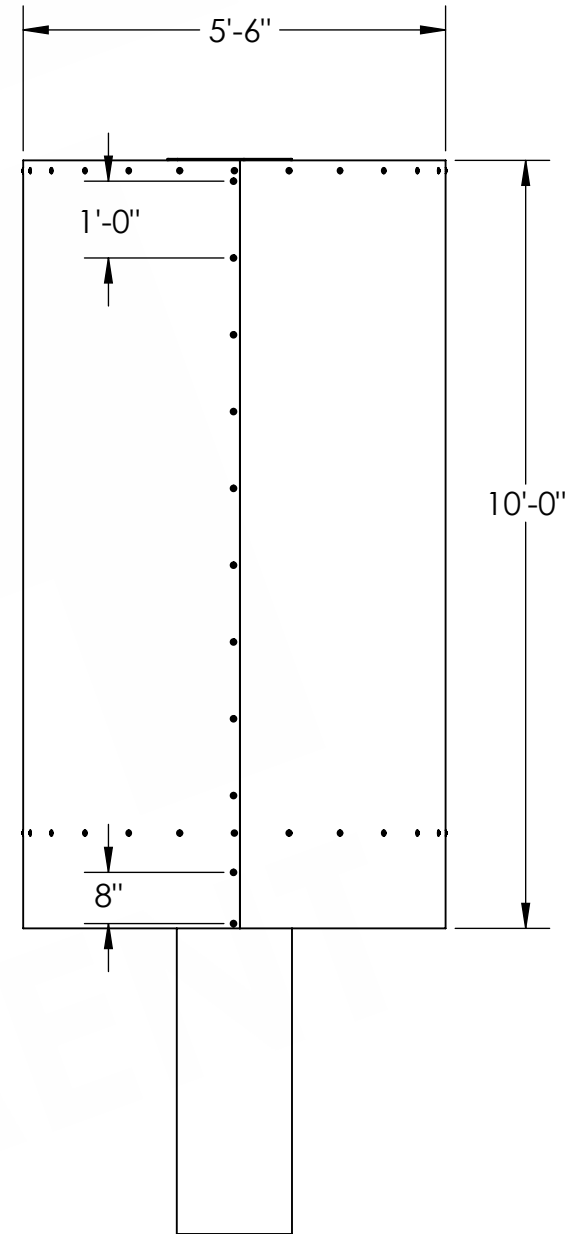
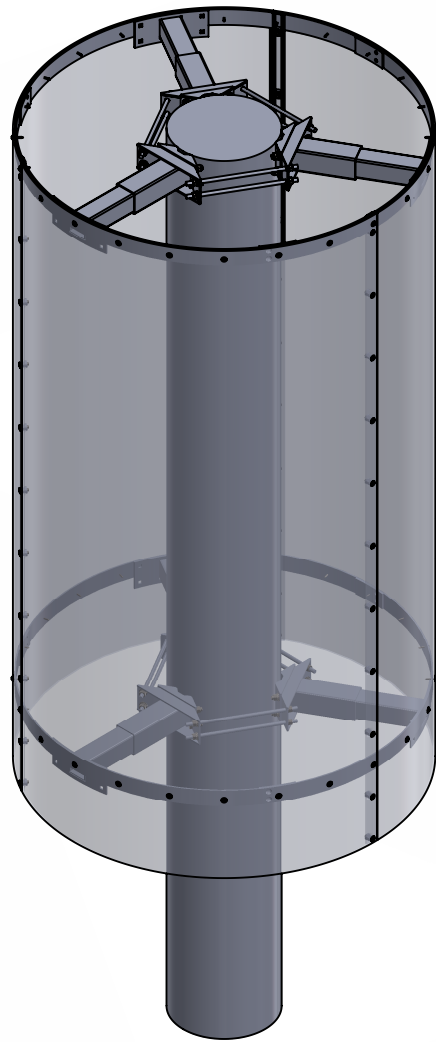

**TNH DEVELOPMENT**

1990 OLIVERA RD SUITE B  
CONCORD, CA 94520

[www.TNHDev.com](http://www.TNHDev.com)

PHONE: 800-916-1503

**PROPRIETARY AND CONFIDENTIAL**

THE INFORMATION CONTAINED IN THIS DRAWING IS THE SOLE PROPERTY OF TNH DEVELOPMENT, LLC. ANY REPRODUCTION IN PART OR AS A WHOLE WITHOUT THE WRITTEN PERMISSION OF TNH DEVELOPMENT, LLC. IS PROHIBITED.

DATE: DESIGNED: DRAFTER:

REVISIONS	
REV	DESCRIPTION

"CARRIER"

OVERVIEW	"SITE NAME"
	SITE# XXXXXXXX "JOB DESCRIPTION" "ADDRESS"

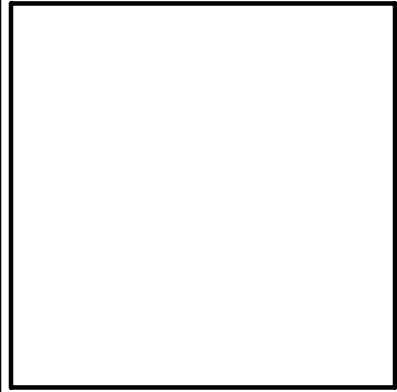

S1	REV
	A
SHEET 4	

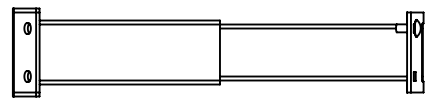

TELESCOPING TUBE LOCKED WITH (2) #12 SELF TAPPING SCREWS. ALLOWS FOR MICRO ADJUSTMENT TO ENSURE RADOME FITS EVERYTIME

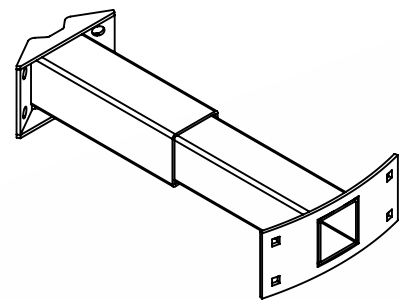
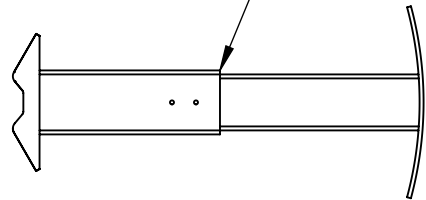

1 SINGLE RADOME ARM ASSEMBLY

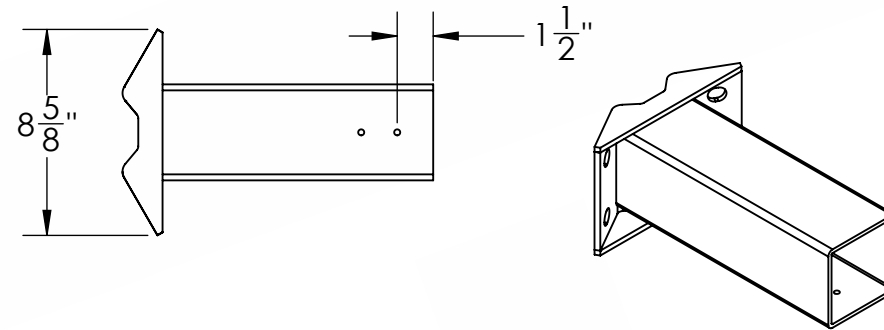
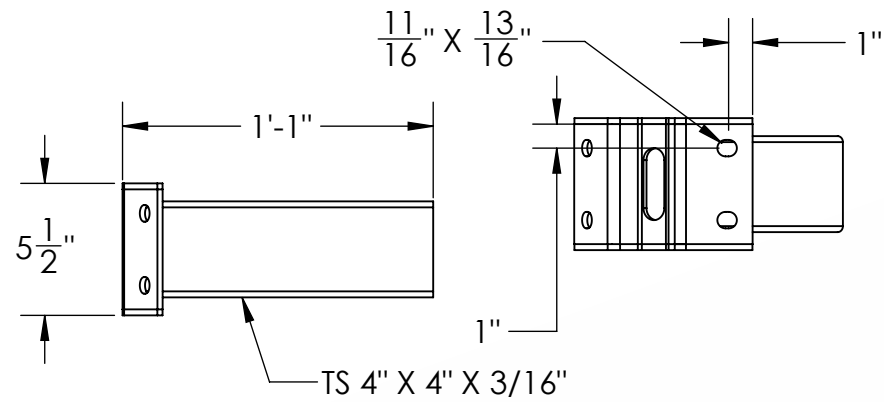

2 PIPE MAST ATTACHMENT

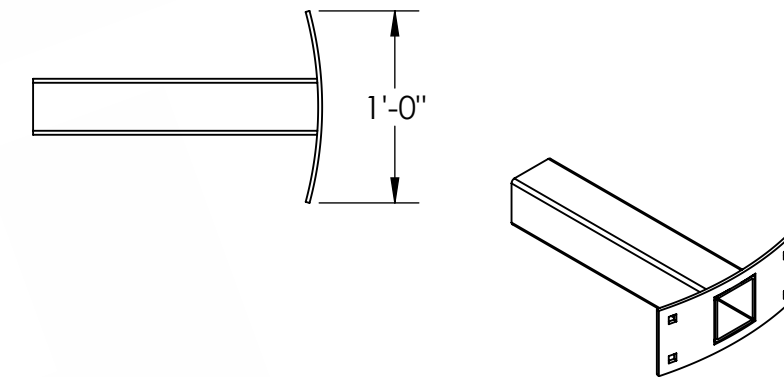
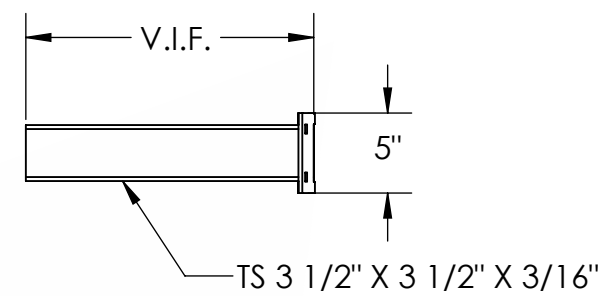

3 RADOME ATTACHMENT

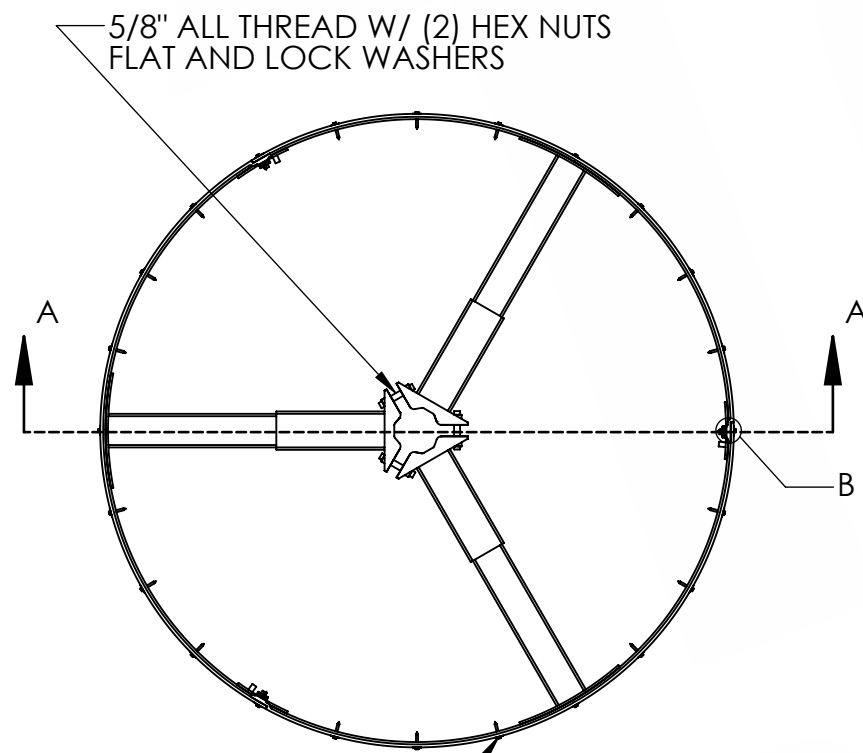

TEKS 5 12-24 W/ FENDER WASHER

4 RADOME (TOP VIEW)

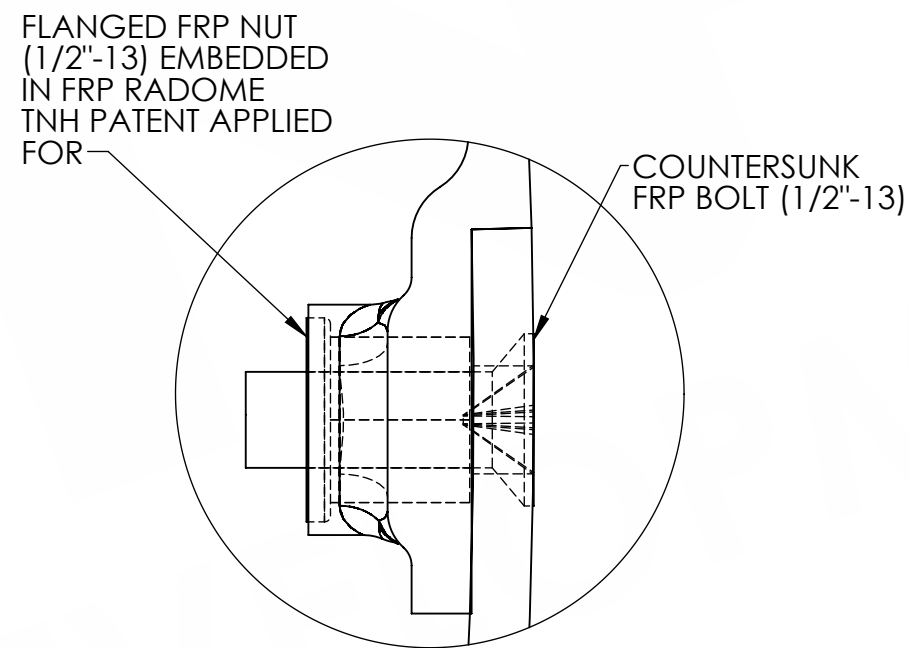

DETAIL B SCALE 1 : 1

5 RADOME SEAM (TOP VIEW)

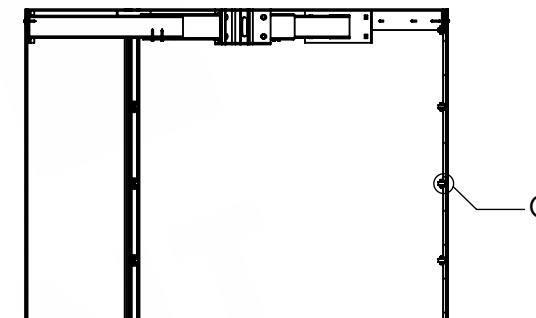

SECTION A-A SCALE 1 : 30

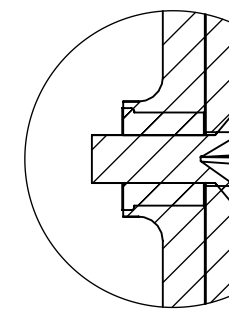

DETAIL C SCALE 1 : 2

6 RADOME SEAM (SIDE VIEW)



**TNH DEVELOPMENT**

1990 OLIVERA RD SUITE B  
CONCORD, CA 94520

[www.TNHDev.com](http://www.TNHDev.com)

PHONE: 800-916-1503

**PROPRIETARY AND CONFIDENTIAL**

THE INFORMATION CONTAINED IN THIS DRAWING IS THE SOLE PROPERTY OF TNH DEVELOPMENT, LLC. ANY REPRODUCTION IN PART OR AS A WHOLE WITHOUT THE WRITTEN PERMISSION OF TNH DEVELOPMENT, LLC. IS PROHIBITED.

DATE: DESIGNED: DRAFTER:

REVISIONS		
REV	DATE	DESCRIPTION

"CARRIER"

DETAILS

"SITE NAME"  
SITE# XXX0000  
"JOB DESCRIPTION"  
"ADDRESS"

S2

REV  
A  
SHEET 5

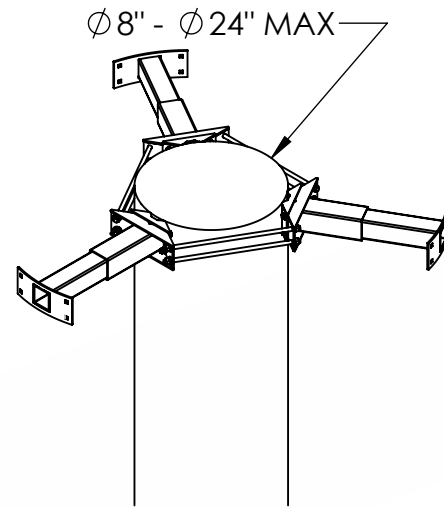
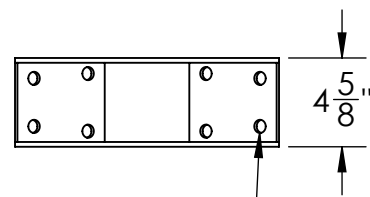
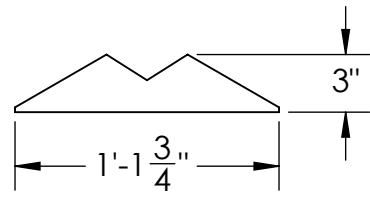

**TNH DEVELOPMENT**

1990 OLIVERA RD SUITE B  
CONCORD, CA 94520

[www.TNHDev.com](http://www.TNHDev.com)

PHONE: 800-916-1503

**PROPRIETARY AND CONFIDENTIAL**

THE INFORMATION CONTAINED IN THIS DRAWING IS THE SOLE PROPERTY OF TNH DEVELOPMENT, LLC. ANY REPRODUCTION IN PART OR AS A WHOLE WITHOUT THE WRITTEN PERMISSION OF TNH DEVELOPMENT, LLC. IS PROHIBITED.

DATE: DESIGNED: DRAFTER:

REVISIONS		
REV	DATE	DESCRIPTION

"CARRIER"

1 MONOPOLE ADAPTER (OPTIONAL)

2

3

OPTIONAL PARTS

"SITE NAME"  
SITE# XXXXXXXX  
"JOB DESCRIPTION"  
"ADDRESS"

4

5

6