

"CARRIER"



1990 OLIVERA RD SUITE B
CONCORD, CA 94520
www.TNHDev.com
PHONE: 800-916-1503

PROPRIETARY AND CONFIDENTIAL

THE INFORMATION CONTAINED IN THIS DRAWING IS THE SOLE PROPERTY OF TNH DEVELOPMENT, LLC. ANY REPRODUCTION IN PART OR AS A WHOLE WITHOUT THE WRITTEN PERMISSION OF TNH DEVELOPMENT, LLC. IS PROHIBITED.

DATE: DESIGNED: DRAFTER:

REVISIONS		
REV	DATE	DESCRIPTION

"CARRIER"

TITLE SHEET	"SITE NAME" SITE# XXX00000 "JOB DESCRIPTION" "ADDRESS"
-------------	---

"SITE NAME"

SITE# XXX00000
"JOB DESCRIPTION"

"ADDRESS"

TABLE OF CONTENTS

- T1 TITLE SHEET
- N1 NOTES
- S1 OVERVIEW
- S2 B.O.M.
- S3 CONNECTION DETAILS
- S4 GLUE & SCREW INFO
- S5 GLUE & SCREW INFO

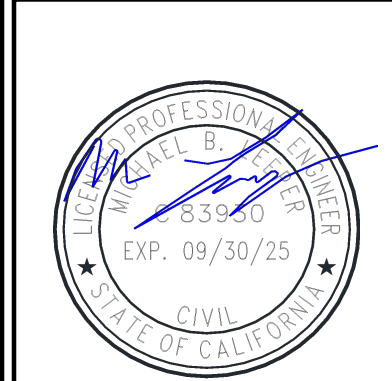

GENERAL NOTES:

1. TNH Development, LLC's standard fabrication and manufacturing tolerances & techniques will apply.
2. Anchor bolts and/or attachment hardware by others unless noted.
3. Existing structure and connection shall be verified by others to support the new vertical and lateral loads of the FRP enclosure.
4. The term "integrated" refers to a procedure used in fiberglass applications where two members are bonded to each other with the use of fiber laminates and fiber-glass resin as the bonding agent.
5. Structure is not intended to be a fully weatherproof structure, any weather proofing if required by others.
6. If prefabricated members are not assembled per plan, contact TNH Development, LLC before cutting or altering fabricated members.
7. The contractor shall protect the FRP structural members from abuse to prevent breakage, nicks gouges, etc. during fabrication, handling, and installation.
8. Antennas & antenna brackets supplied and installed by others unless otherwise noted.
9. Standard finish is factory primer. Final painting by others unless otherwise noted.
10. The words "the engineer" as used in these notes, refer to a representative of TNH Development, LLC.
11. The general contractor shall become familiar with all existing site conditions and with all design documents provided by the various design professionals involved in this project.
12. The general contractor shall verify all dimensions, details and spacial relationships shown on these drawings in conjunction with all other related design drawings. Any discrepancies, conflicts or omissions found shall be reported to the engineer and other design professionals as appropriate for resolution prior to proceeding with any work on the project.
13. All work shall comply with the currently adopted edition of the california building code and all state and local codes and ordinances.
14. Any testing or inspections required by building officials or the project drawings or specifications shall be performed by an approved independent testing laboratory.
15. Observation visits to the site by the engineer shall neither be construed as inspection nor approval of construction.
16. The general contractor is solely responsible for compliance with O.S.H.A. standards.
17. All A.S.T.M. specifications noted on the drawings shall be as amended to date.
18. Details and notes on these plans are typical. Similar requirements apply to similar conditions.
19. These drawings are not final until final approval from all governing agencies is received and a permit has been issued. All quantity, grades and sizes of structural components may change. Bids/Pricing performed on plans not yet approved and permitted may change and should not be relied upon for budgets or final costs.

FIBER REINFORCED POLYMER (FRP):

1. FRP structural shapes shall be STRONGWELL EXTREN® SERIES 500/525 manufactured using the pultrusion process.
2. This section includes the following FRP products and fabrications:
 - A. FRP panels
 - B. FRP structural shapes
3. FRP wall panel systems are to meet the following requirements:
 - A. All FRP products to be STRONGWELL in accordance with Los Angeles City Research Report 25698.
 - B. Panels are to match the existing building color and texture to the satisfaction of PDC, Lease owner and Landlord (or owner).
 - C. Panel system must be able to span between supports provided and resist a design wind load of 28 pounds per square foot per LARR 25698 (or larger), perpendicular to the panel surface with a maximum deflection ration of less than L/60.
 - D. Acceptability of the panel RF Transparency is subject to the approval of lease owner.
 - E. Refer to project specification for additional requirements.
4. All FRP products specified in these design drawings shall be as follows:
 - A. Structural shapes and plate: STRONGWELL EXTREN® SERIES 500/525. All structural shapes shall consist of a glass fiber reinforced polyester or vinyl ester resin matrix, approximately 50% resin to glass ration. Glass strand roving shall be used in the longitudinal direction and continuous strand mats shall be used for transverse reinforcement.
 - B. Fasteners: Where specified as FRP fasteners shall be FIBERGRATE threaded rod and nuts. Typically bolts within the area of the antenna signal to be FRP. All other bolts to be ASTM A307.
5. All FRP panels and structural members shall be manufactured using the pultruded process utilizing either an isophthalic polyester or vinyl ester resin with flame retardant and ultraviolet (UV) inhibitor additives. A synthetic surface veil shall be the outermost layer covering the exterior surface.
6. The contractor is to furnish all labor, materials, equipment and incidentals necessary to install the FRP products as specified herein.

7. Shop drawings are not automatically required for approval by the engineer of record unless specifically noted as required. This does not preclude that others, such as the client or construction management may require some form of shop drawings.
 - A. Dimensions
 - B. Erection instruction and sectional assemblies
 - C. Location and identification marks
 - D. Size and type of shoring or temporary support framing
 - E. Material specifications and supporting data as necessary
8. Contractor may be required to submit samples of specific products for approval prior to installation and placement of purchase orders.
9. All field cut or drilled edges of FRP structural members to be coated by others with resin or acrylic sealer compatible with the resin matrix used in the structural shape.
10. FRP structural members shall be fabricated and assembled as indicated on the drawings.
11. The contractor shall protect the FRP structural members from abuse to prevent breakage, nicks, gouges, etc. during fabrication, handling, and installation.
12. FRP bolts should be tightened and locked with epoxy.
13. FRP connection shall conform to the following requirements:
 - A. Structural member connections:
 - (1) All fiberglass nuts and studs are to be lubricated with either a light oil, dry lubricant or silicone spray.
 - (2) All connections to be torqued to the following requirements:
 - 3/8" BOLT -----4FT-LBS
 - 1/2" BOLT -----8FT-LBS
 - 5/8" BOLT -----16FT-LBS
 - 1" BOLT -----50FT-LBS
 - (3) All bolts to be torqued using a calibrated torque wrench.
 - (4) Fiberglass stud/nut assemblies shall be bonded to insure that the nuts do not loosen. This can be accomplished by applying a thick layer of adhesive or resin to cover the exposed assembly.
 - (5) Structural connection unless otherwise noted in the design drawings rely on a combination of bolt bearing and adhesive bonding. Epoxy adhesives recommended for connections are shell 828 epoxy resin, DOW D.E.R. 331 epoxy resin or HIGH PERFORMANCE MMA METHACRYLATE ADHESIVE EPOXY adhesive. Sand mating surfaces with 120 grit sandpaper to remove polyester surfacing veil and clean joining surfaces with a compatible solvent prior to bonding. Joints should be properly clamped in accordance with manufacturer's recommendations and held in position for at least 48 hours (at 70 degrees, refer to manufacturer to other temperatures) before design load can be applied.
 - (6) Minimum edge distance of fasteners to the side of member shall be one and a half diameters and two diameters to the member end (or minimum of 1.5"). Minimum bolt spacing to be four diameters.

MAKING THE ADHESIVE JOINT:

Before polyester-fiberglass shapes can be bonded or glued, the surface must be prepared to insure proper adhesion. Contaminated surfaces should be thoroughly cleaned by wiping with a clean cloth dampened with a solvent such as acetone, toluol, or methyl alcohol prior to sanding. Wipe dry with a clean cloth. Do not immerse or soak EXTREN® shapes in these solvents.

1.Procedure for making structural epoxy joints:

- A. Materials used:
 - (1) STRONGWELL epoxy adhesive base
 - (2) STRONGWELL epoxy adhesive hardener
 - (3) Small wax coated paper cup for mixing
 - (4) Clean wooden or FRP stick for mixing
 - (5) 120 grit sandpaper
 - (6) Clamps for holding epoxy joints during cure
 - (7) Clean cloth
- B. Surface Preparation:
 - (1) Sand mating surfaces with 120 grit sandpaper until the surface glass has been removed. The surfacing veil must be ground off to expose the glass reinforcement. Sand blasting equipment can also be used.
 - (2) Remove all dust with a clean cloth; air blasting equipment may also be used. Avoid recontamination of the surface from handling.
- C. Mixing of Epoxy:
 - (1) Mix equal volume portions of the base and hardener in a small wax coated paper cup with a clean stick until a uniform fray color is attained and all marbled appearance is gone.

NOTE: Other adhesive systems compatible with fiberglass can be utilized and the manufacturer's mixing instructions for these systems should be followed.

- D. Application and cure:
- 1) Apply the mixed epoxy uniformly to all surfaces to be joined. A thin application is often more beneficial than a thick application.
 - 2) Avoid introducing moisture into the joint.
 - 3) Join the surface to be bonded. The pot life at 77°F for a 3 oz mixture of equal volumes of base and hardener is 2.5 hours.
 - 4) Secure the joint with clamps (or rivets or bolts) and allow 24 hours for a full cure. The assembly can often be handled with reasonable care in less than 8 hours. The structure should not be required to support its design load until at least 48 hours (at 70°F) after bonding. Lower temperatures require a longer cure.
 - 5) After securing the joint, wipe away excess epoxy.

STRUCTURAL STEEL:

1. All structural steel shall conform to A.S.T.M. A36 unless noted otherwise.
2. Structural steel W sections, shall conform to A.S.T.M. A992 grade 50.
3. Steel pipe columns shall conform to A.S.T.M. A501, Fy=36 Ksi or A.S.T.M. A53, types E or S, grade B, Fy=35 Ksi.
4. Structural tube steel columns shall conform to A.S.T.M. A500, grade B, Fy=46 Ksi.
5. Bolts shall conform to A.S.T.M. A325 unless noted otherwise.
6. Diameter of bolt holes in steel shall be 1/16" larger than the bolt size unless noted otherwise.
7. All welds shall be in conformity with the structural welding code of american welding society (A.W.S.)
8. Anchor bolts shall conform to either A.S.T.M. A325 or A36 unless noted otherwise, and shall be headed bolts or threaded rod with double nuts.
9. Protect all steel columns, base plates, anchor bolts, embedment plates, weld plates, etc. below top of floor slab with a minimum of 3" of concrete cover.
10. Fabrication and erection shall comply with A.I.S.C. specifications for buildings, as revised to date.
11. Steel framing dimensions are to the centerlines of columns and W shapes and to the smooth face of channels.
12. Verify all dimensions with architectural and mechanical drawings. coordinate any conflicts before proceeding.
13. Steel beams shall be placed with mill camber upward.

DISCLAIMERS:

All structural components to be connected together shall be completely fit-up on the ground or otherwise verified for compatibility prior to lifting any component into place. Repairs required due fit-up or connection compatibility problems after partial erection are the financial responsibility of the contractor.

STRUCTURAL OBSERVATION:

NO STRUCTURAL OBSERVATION IS REQUIRED.

DESIGN CODE:

2019 CALIFORNIA BUILDING CODE
TIA-H-222

INSPECTIONS:

1. Contractor shall know and comply with requirements of governing agency by informing building department when required inspections are to take place.
2. Inspections are required for:
 - A. ALL structural steel work
 - B. All concrete work
 - C. All masonry work
 - D. All reinforcing steel
 - E. All excavations
3. Special Inspections:
 - A. The owners shall employ special inspectors who shall provide additional inspections during construction in accordance with CBC Chapter 17.
 - B. All special inspections shall be performed by an independent certified inspector from an established testing agency, licensed and approved by the building department.
 - C. All inspections shall be continuous, unless otherwise noted.



DEVELOPMENT

1990 OLIVERA RD SUITE B
CONCORD, CA 94520
www.TNHDev.com
PHONE: 800-916-1503

PROPRIETARY AND CONFIDENTIAL

THE INFORMATION CONTAINED IN THIS DRAWING IS THE SOLE PROPERTY OF TNH DEVELOPMENT, LLC. ANY REPRODUCTION IN PART OR AS A WHOLE WITHOUT THE WRITTEN PERMISSION OF TNH DEVELOPMENT, LLC. IS PROHIBITED.

DATE: DESIGNED: DRAFTER:

REVISIONS

REV	DATE	DESCRIPTION

"CARRIER"

NOTES	"SITE NAME" SITE# XXXXXXX	"JOB DESCRIPTION" "ADDRESS"

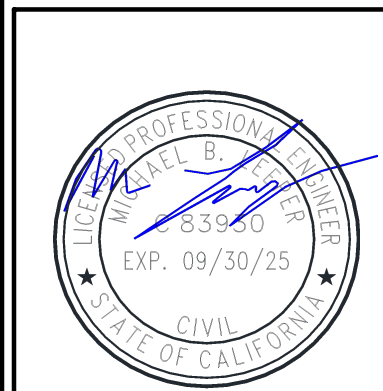

N1	REV
	A
	SHEET 2

WALL MOUNTED BOX 8' X 8' X 2'



1990 OLIVERA RD SUITE B
CONCORD, CA 94520
www.TNHDev.com
PHONE: 800-916-1503

PROPRIETARY AND CONFIDENTIAL
THE INFORMATION CONTAINED IN THIS DRAWING IS THE SOLE PROPERTY OF TNH DEVELOPMENT, LLC. ANY REPRODUCTION IN PART OR AS A WHOLE WITHOUT THE WRITTEN PERMISSION OF TNH DEVELOPMENT, LLC. IS PROHIBITED.

DATE: DESIGNED: DRAFTER:

REVISIONS	
REV	DESCRIPTION

"CARRIER"

OVERVIEW	"SITE NAME"
	SITE# XXXXXXXX
	"JOB DESCRIPTION"
	"ADDRESS"

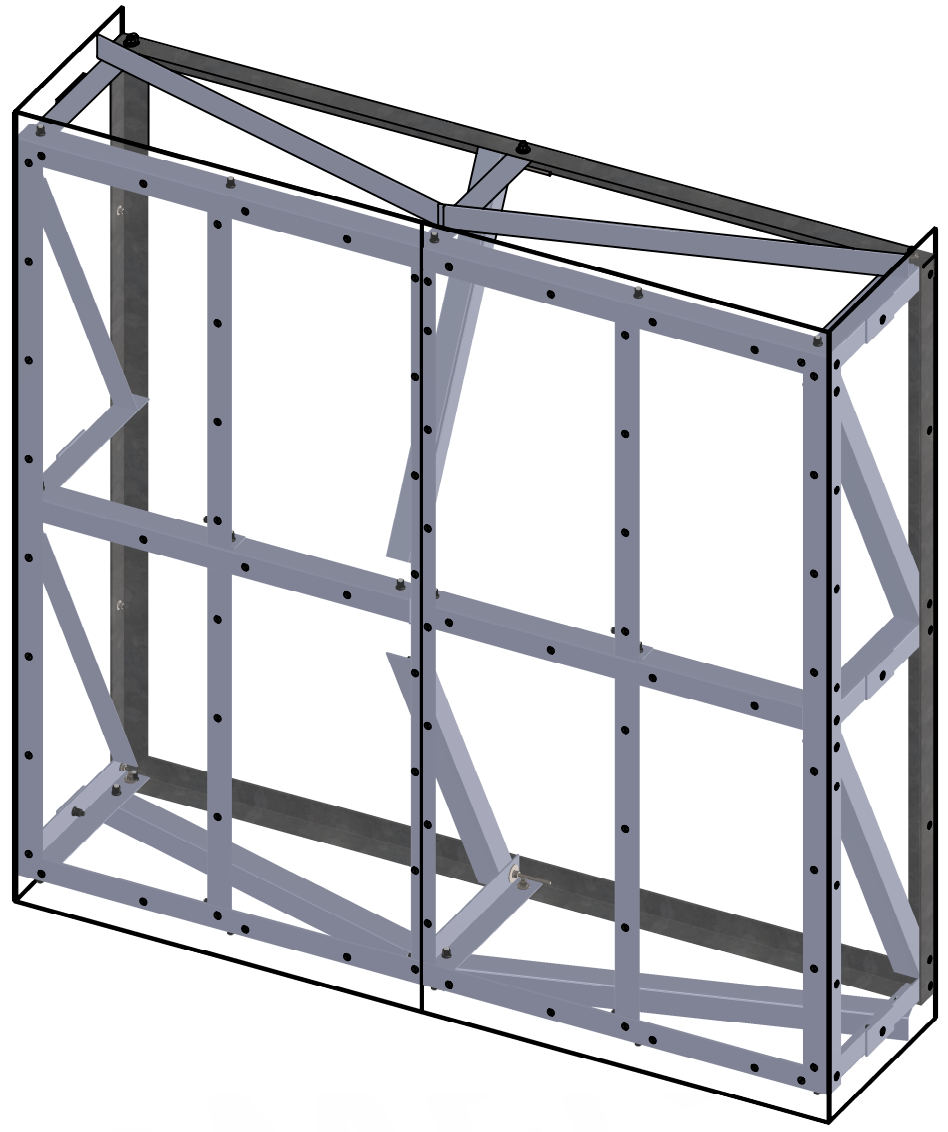
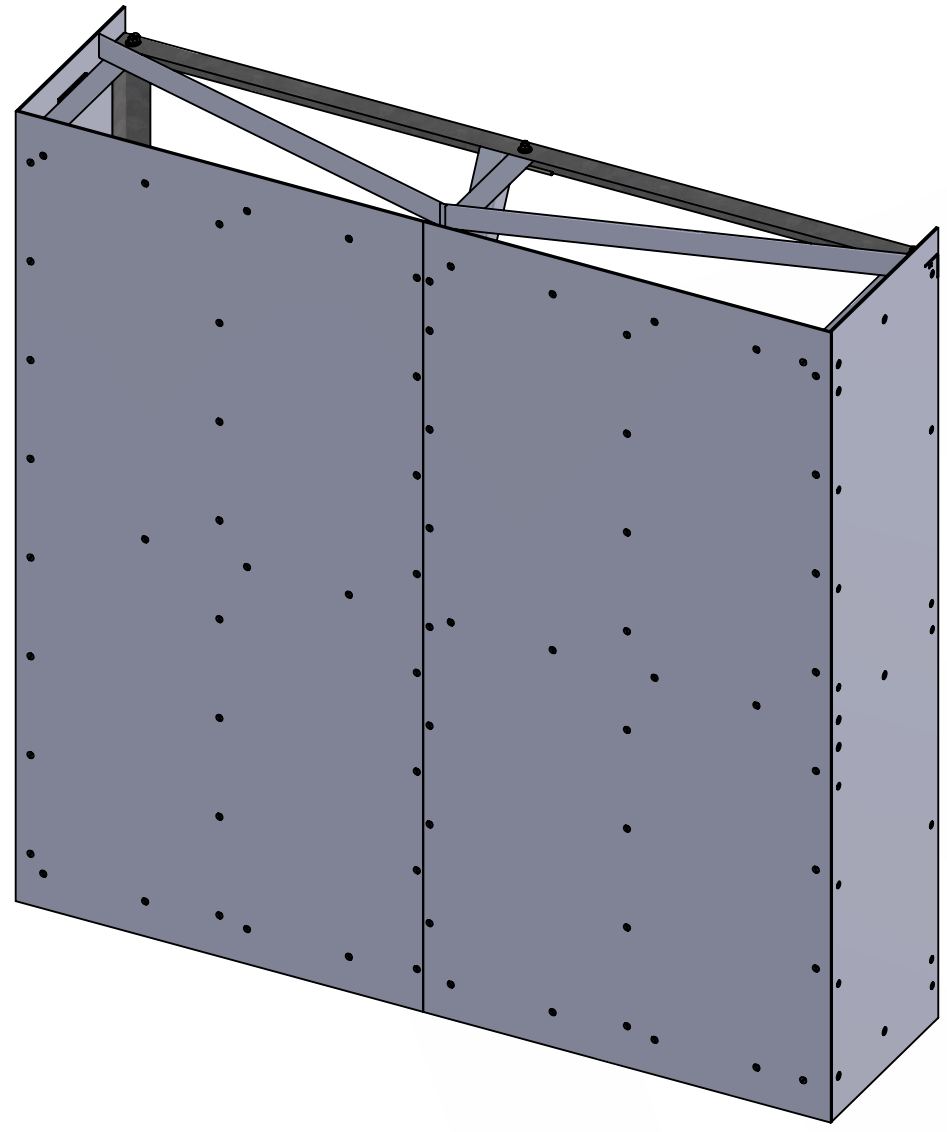

ITEM NO.	RAW STOCK B.O.M.	QTY.
1	3"X1/4"X20' FRP ELA	6
2	3"X1/4"X20' STEEL ELA	2
3	4'X1/4"X8' FRP PANEL	3
4	1/2"X8' FRP ALLTHREAD	2
5	1/2"X2" SLOT FLAT HEAD	16
6	1/2"-13 FRP HEX FLANGENUT	92
7	3/8"X1 1/2" FLAT HEAD BOLT	87
8	3/8"-16 A307 CS BOLT, F/L WASHERS, HEX NUT	14
9	1/2"-13 A307 HEX BOLT, F/L WASHERS, HEX NUT	6
10	TEKS® 5 12-24	120
11	SIKAFLEX-221	4

S1
REV A
SHEET 3



1990 OLIVERA RD SUITE B
CONCORD, CA 94520
www.TNHDev.com
PHONE: 800-916-1503

PROPRIETARY AND CONFIDENTIAL
THE INFORMATION CONTAINED IN THIS DRAWING IS THE SOLE PROPERTY OF TNH DEVELOPMENT, LLC. ANY REPRODUCTION IN PART OR AS A WHOLE WITHOUT THE WRITTEN PERMISSION OF TNH DEVELOPMENT, LLC. IS PROHIBITED.

DATE: DESIGNED: DRAFTER:

REVISIONS		
REV	DATE	DESCRIPTION

"CARRIER"

B.O.M.
"SITE NAME"
SITE# XXX0000
"JOB DESCRIPTION"
"ADDRESS"



S2
REV A
SHEET 4

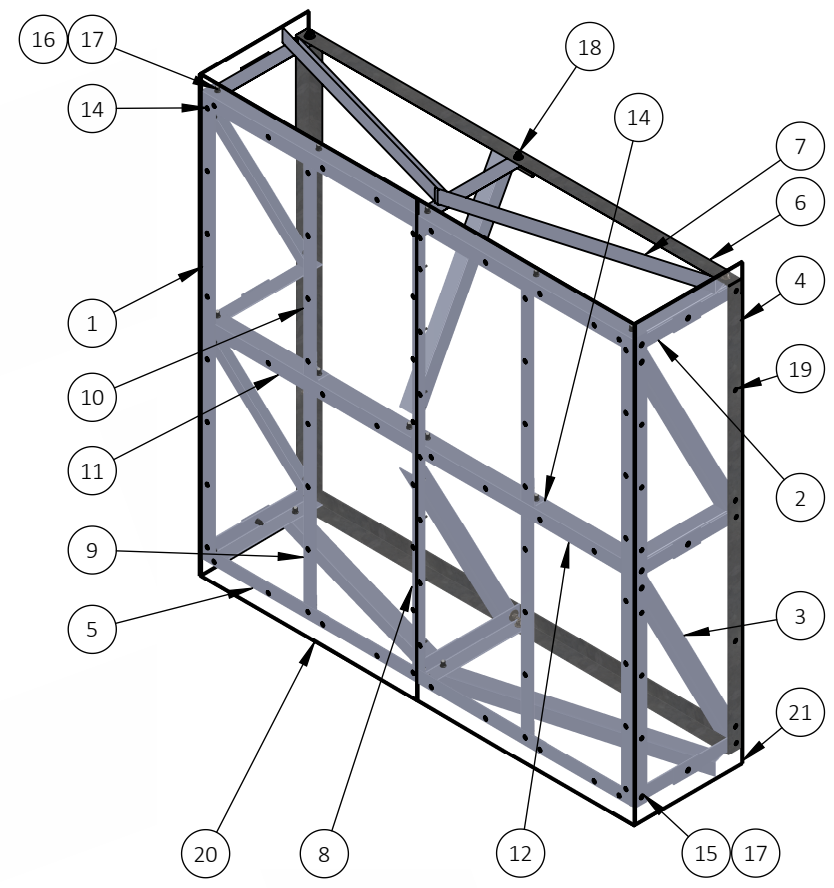
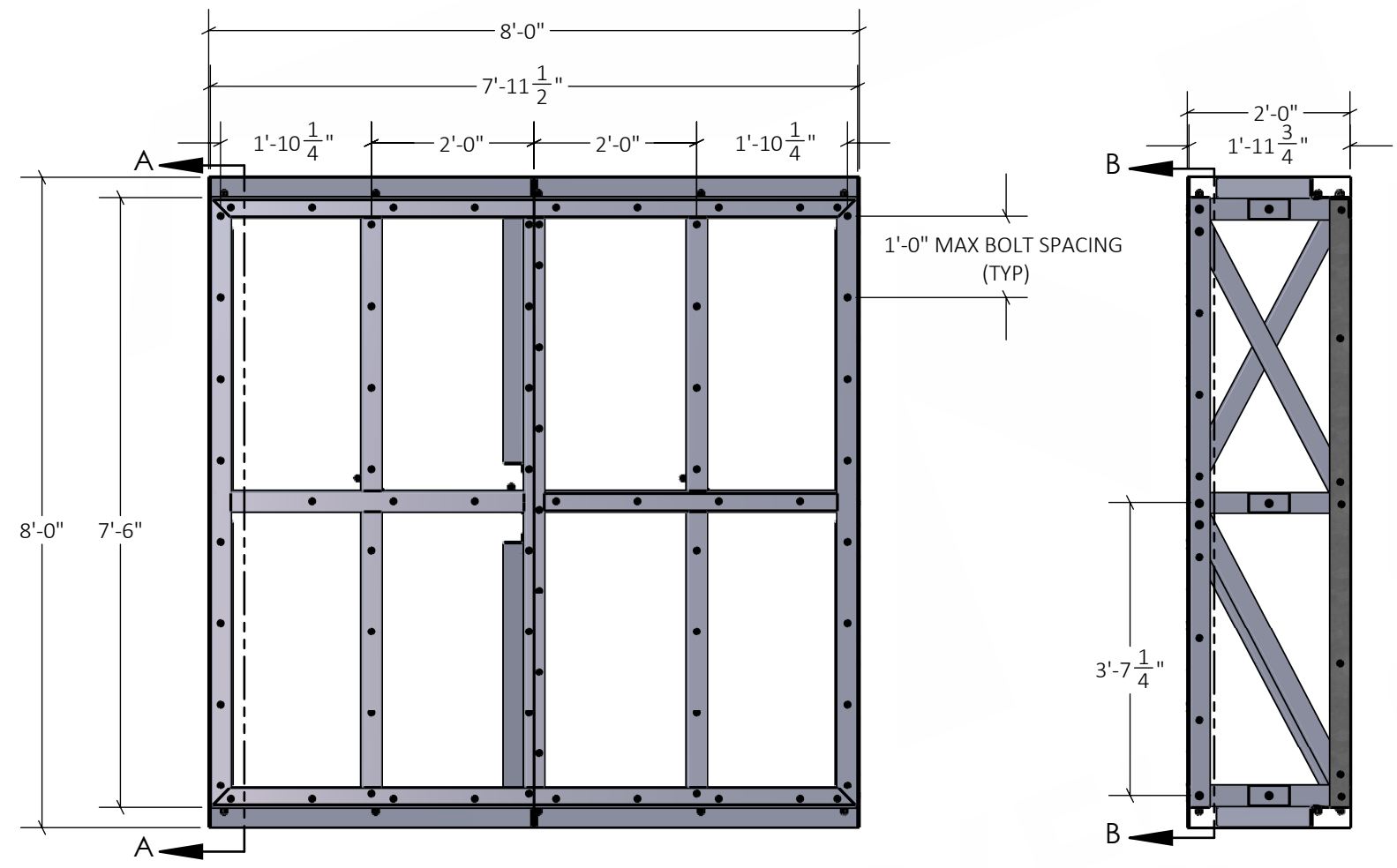
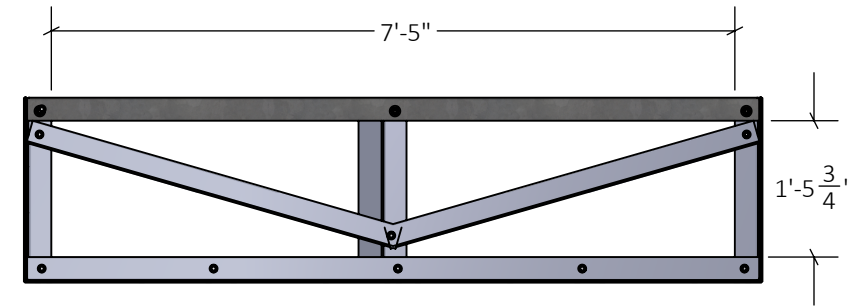

NOTE: ALL LENGTHS IN B.O.M. WILL NEED TO BE FIELD CUT

ITEM NO.	PART NAME	LENGTH	QTY.
1	3"X1/4" FRP ELA	7'-6"	2
2	3"X1/4" FRP ELA	1'-11 1/4"	8
3	3"X1/4" FRP ELA	3'-8"	6
4	3"X1/4" STEEL ELA	7'-6"	2
5	3"X1/4" FRP ELA	5'-11 1/2"	2
6	3"X1/4" STEEL ELA	5'-11 1/2"	2
7	3"X1/4" FRP ELA	4'-2"	4
8	3"X1/4" FRP ELA	7'-5 1/2"	1
9	3"X1/4" FRP ELA	3'-10 1/4"	2
10	3"X1/4" FRP ELA	3'-7"	2
11	3"X1/4" FRP ELA	3'-9 3/4"	1
12	3"X1/4" FRP ELA	4'-3/4"	1
13	3"X1/4" FRP ELA	2 3/4"	12
14	3/8"X1 1/2" FRP FLATHEAD BOLT	1 1/2"	87
15	1/2"X2" FRP FLATHEAD BOLT	2"	14
16	1/2" FRP ALLTHREAD	3"	39
17	1/2"-13 FRP HEX FLANGENUT		92
18	1/2"-13 A307 HEX BOLT, F/L WASHERS, HEX NUT	1 1/2"	6
19	3/8"-16 A307 CS BOLT, F/L WASHERS, HEX NUT	1 1/2"	14
20	4'X8'X1/4" FRP PANEL		2
21	1'-11 3/4"X8'X1/4" FRP PANEL		2



1990 OLIVERA RD SUITE B
CONCORD, CA 94520
www.TNHDev.com
PHONE: 800-916-1503

PROPRIETARY AND CONFIDENTIAL
THE INFORMATION CONTAINED IN THIS DRAWING IS THE SOLE PROPERTY OF TNH DEVELOPMENT, LLC. ANY REPRODUCTION IN PART OR AS A WHOLE WITHOUT THE WRITTEN PERMISSION OF TNH DEVELOPMENT, LLC. IS PROHIBITED.

DATE: DESIGNED: DRAFTER:

REVISIONS		
REV	DATE	DESCRIPTION

"CARRIER"

CONNECTION DETAILS

"SITE NAME"
SITE# XXXXXXX
"JOB DESCRIPTION"
"ADDRESS"



S3	REV
	A
	SHEET 5

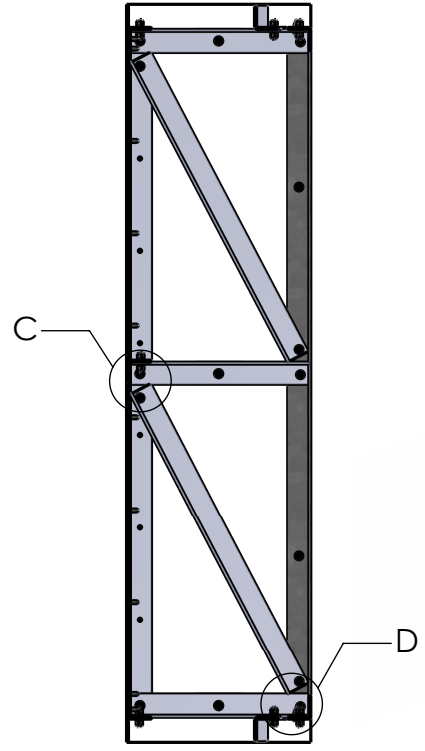

SECTION A-A
SCALE 1 : 25

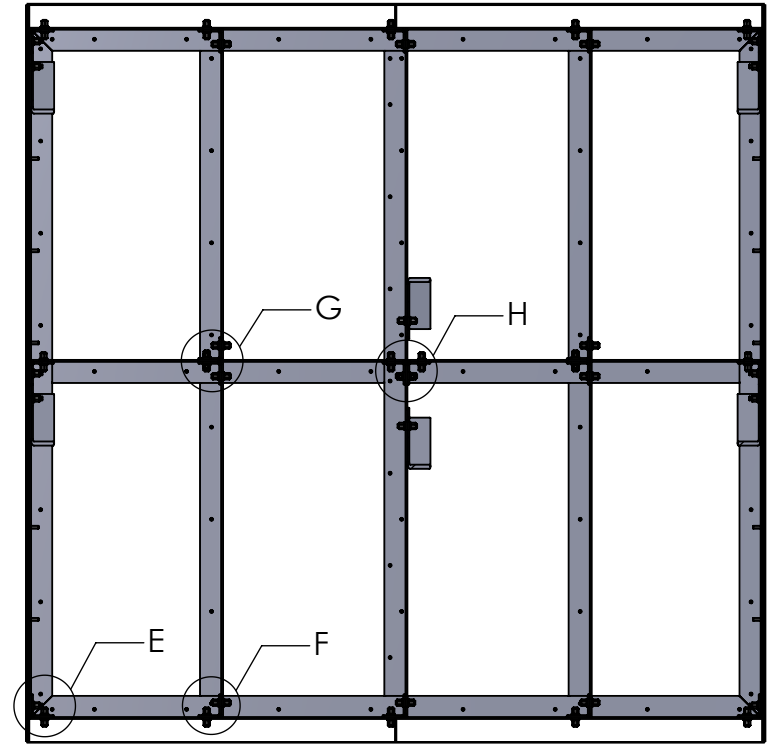

SECTION B-B
SCALE 1 : 25

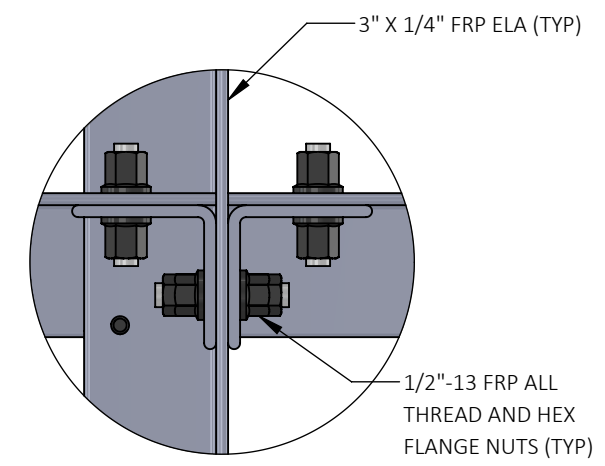

DETAIL H
SCALE 1 : 4

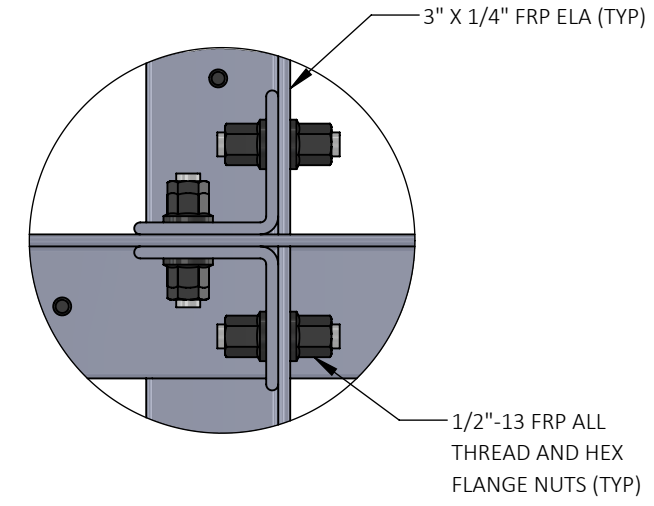

DETAIL G
SCALE 1 : 4

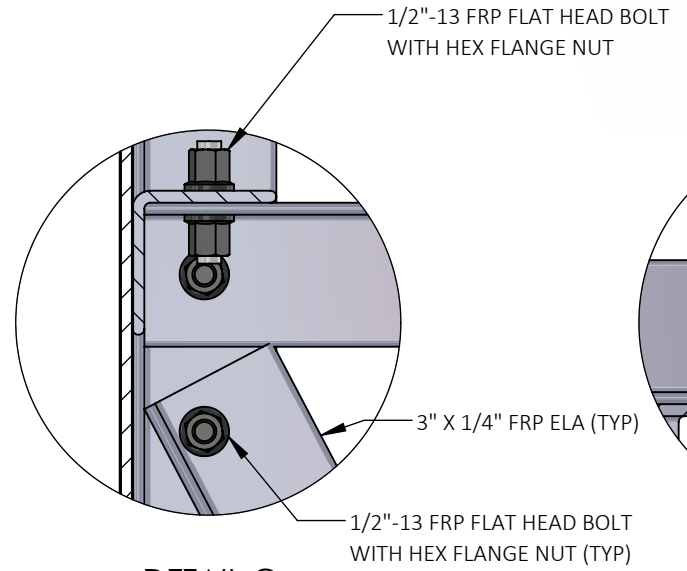

DETAIL C
SCALE 1 : 4

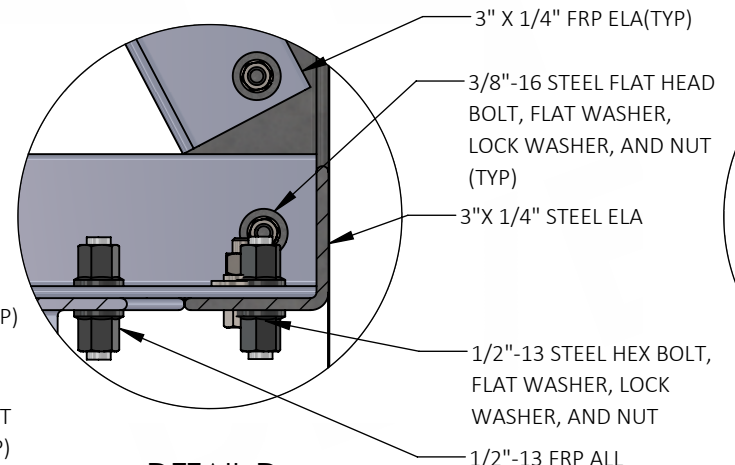

DETAIL D
SCALE 1 : 4

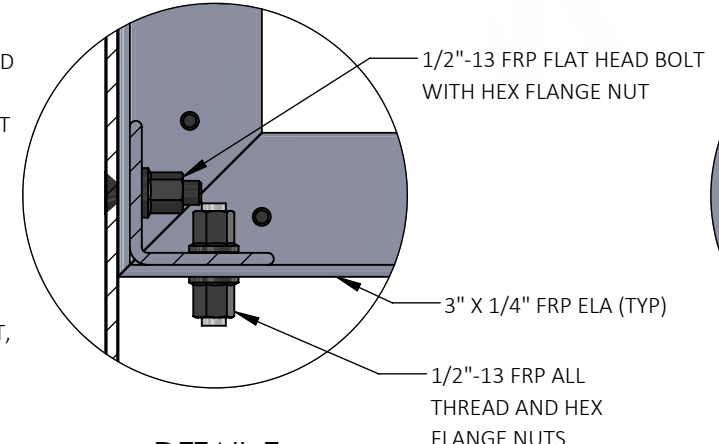

DETAIL E
SCALE 1 : 4

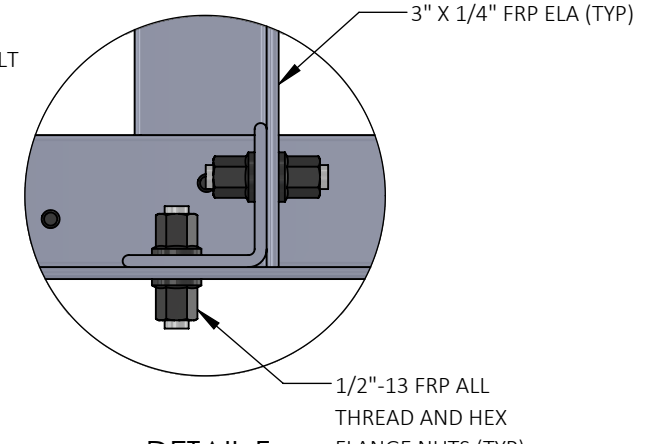

DETAIL F
SCALE 1 : 4

STEP: 1

THOROUGHLY CLEAN BOTH FRAMING MEMBERS AT THEIR MATING LOCATIONS USING A CLEAN CLOTH DAMPENED WITH A SOLVENT SUCH AS ACETONE, TOLUOL, OR METHYL ALCOHOL BEFORE SANDING BOTH LOCATIONS WITH 120 GRIT SAND PAPER TO INCREASE ADHESION BEFORE APPLYING SIKAFLEX 221 GLUE.



STEP: 2

SECURE MEMBERS TOGETHER WITH TEK 5 HWH 12-24 X 1-1/2" SCREWS AT THE MATING LOCATIONS. FROM THE INSIDE OUT BE SURE MEMBERS ARE FLUSH TO EACH OTHER AND THE GLUE CAN BE SEEN AT THE SEAMS TO ENSURE COMPLETE COVERAGE AND PROPER ADHESION. AFTER 24 HOURS ALL TEK SCREWS IN THE FRAMING ARE TO BE REMOVED FROM ONE SIDE AT A TIME BEFORE PANEL INSTALLATION.

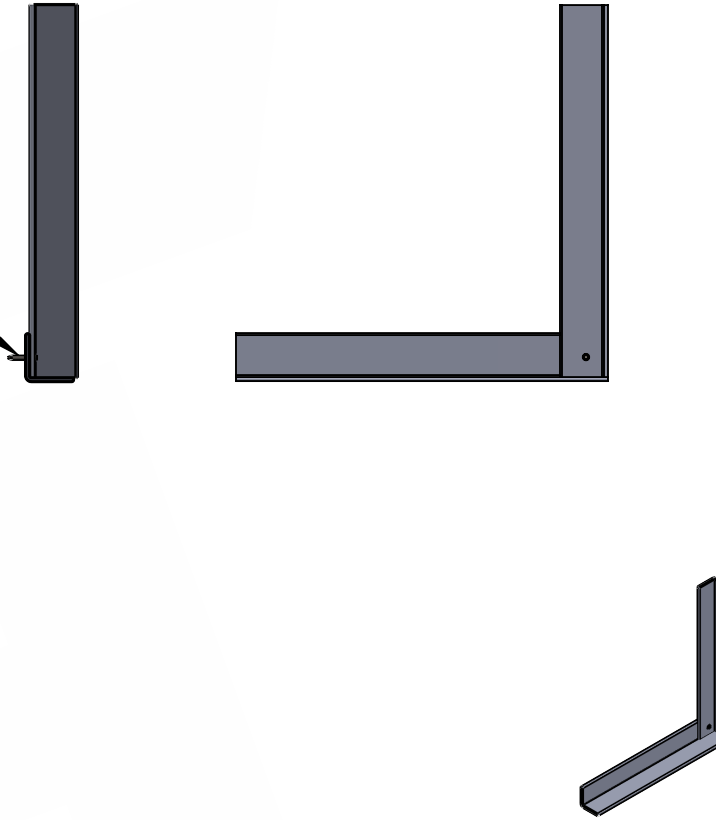

STEP: 3

THOROUGHLY CLEAN BOTH THE FRAMING MEMBER AND MATING LOCATION OF PANEL USING A CLEAN CLOTH DAMPENED WITH A SOLVENT SUCH AS ACETONE, TOLUOL, OR METHYL ALCOHOL BEFORE SANDING BOTH LOCATIONS WITH 120 GRIT SAND PAPER TO INCREASE ADHESION BEFORE APPLYING SIKAFLEX 221 GLUE ALONG THE ENTIRE FRAMING MEMBER



STEP: 4

SECURE PANEL TO MEMBER WITH TEK 5 HWH 12-24 X 1-1/2" SCREWS EVERY 12" (MAX) O.C. AT THE PANEL SEAMS STAGGER THE BOLT SPACING AS SHOWN. BE SURE PANEL IS FLUSH TO THE MEMBER AND THE GLUE CAN BE SEEN AT THE SEAMS TO ENSURE COMPLETE COVERAGE AND PROPER ADHESION. IF POSSIBLE, FLOAT PANELS ABOVE THE FRAMING. THIS WILL HELP "TRUE" THE BOX UPON COMPLETION.

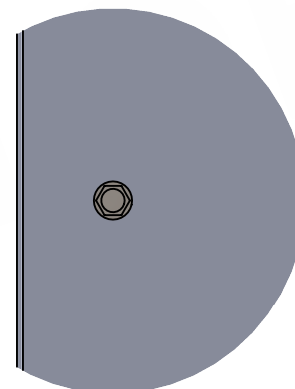

DETAIL A
SCALE 1 : 2

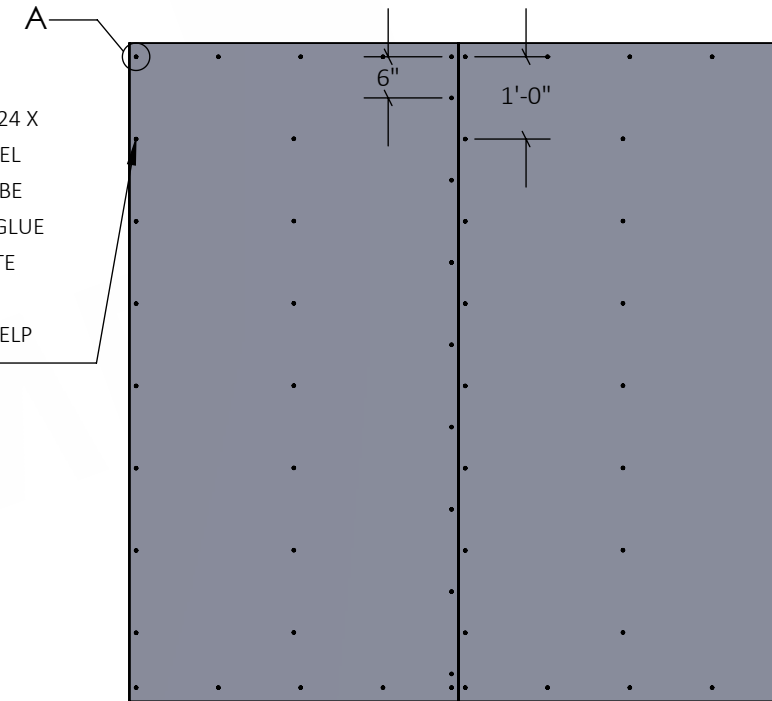

1990 OLIVERA RD SUITE B
CONCORD, CA 94520
www.TNHDev.com
PHONE: 800-916-1503

PROPRIETARY AND CONFIDENTIAL

THE INFORMATION CONTAINED IN THIS DRAWING IS THE SOLE PROPERTY OF TNH DEVELOPMENT, LLC. ANY REPRODUCTION IN PART OR AS A WHOLE WITHOUT THE WRITTEN PERMISSION OF TNH DEVELOPMENT, LLC. IS PROHIBITED.

DATE: DESIGNED: DRAFTER:

REVISIONS		
REV	DATE	DESCRIPTION

"CARRIER"

GLUE & SCREW INFO	"SITE NAME"
	SITE# XXX0000
GLUE & SCREW INFO	"JOB DESCRIPTION"
	"ADDRESS"

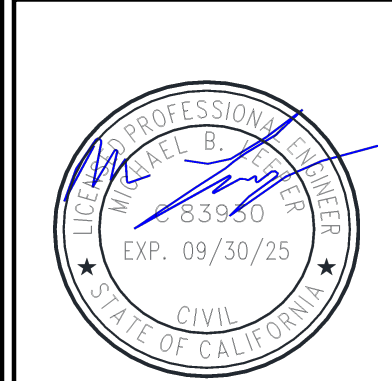

S4	REV
	A
	SHEET 6

STEP: 5

AFTER 24 HOURS FOR THE GLUE TO SET REMOVE TEK SCREWS ONE AT A TIME. DRILL AND TAP PILOT HOLES LEFT BEHIND WITH GREENLEE 3/8"-16 TAP AND COUNTERSINK THE HOLES IN THE PANEL WITH RYOBI 3/4" X 82° COUNTERSINK. BE SURE TO BLOW OUT/REMOVE ANY DEBRIS OR DUST LEFT BEHIND IN THE HOLES AFTER COUNTERSINKING.

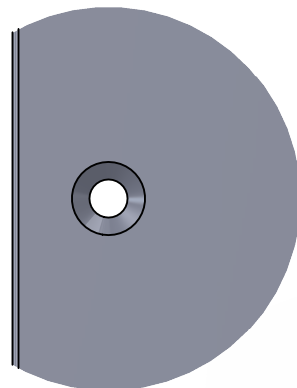
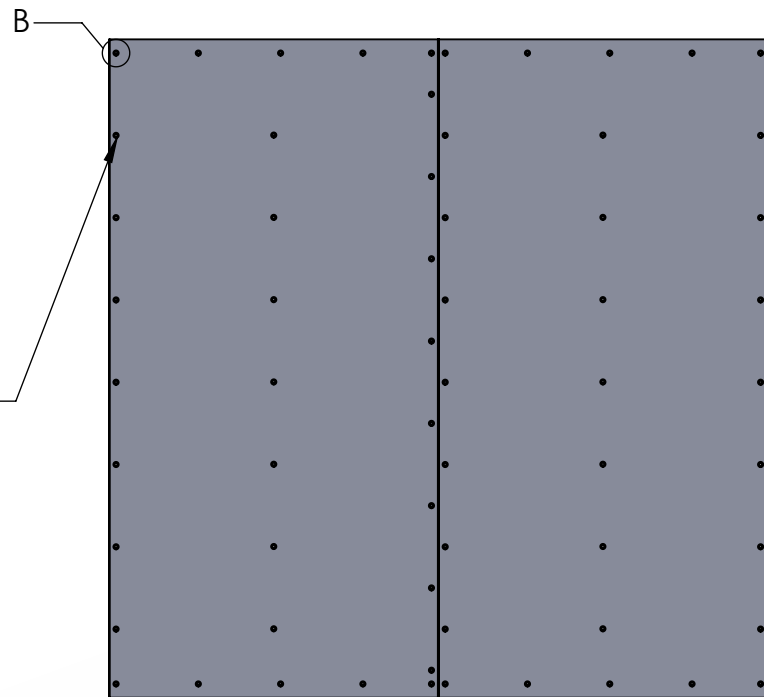

DETAIL B
SCALE 1 : 2



STEP: 6

INSTALL 3/8"-16 COUNTERSUNK FRP BOLTS USING MODIFIED 3/4" SPADE BIT GROUND FLUSH LIKE SHOWN. APPLY A DAB OF MH READY PATCH SPACKLING OR 310 HIGH PERFORMANCE MMA METHACRYLATE ADHESIVE EPOXY (EXAMPLES PICTURED BELOW) AND SMOOTH FLUSH WITH PUTTY KNIFE TO COMPLETE PANEL INSTALLATION

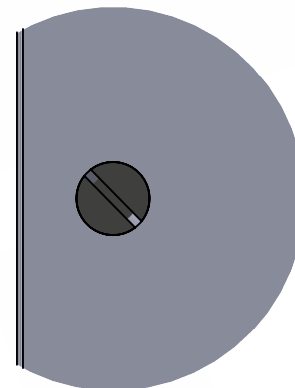
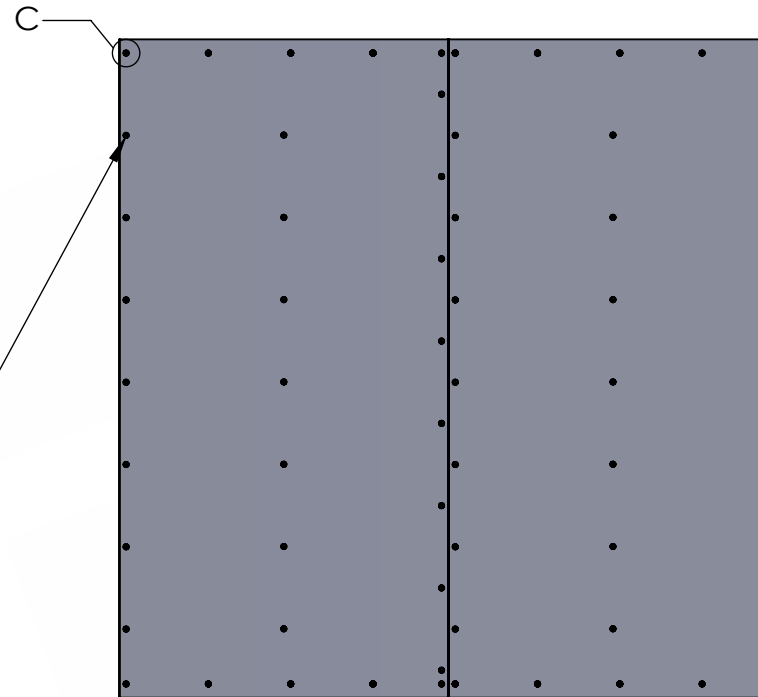

DETAIL C
SCALE 1 : 2



STEP: 7

APPLY MH READY PATCH SPACKLING OR 310 HIGH PERFORMANCE MMA METHACRYLATE ADHESIVE EPOXY (EXAMPLES PICTURED BELOW) TO ALL PANEL SEAMS AND GAPS. SMOOTH FLUSH WITH PUTTY KNIFE. GRIND THE CORNERS SHARP.

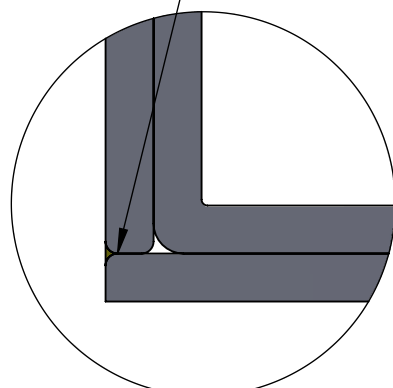
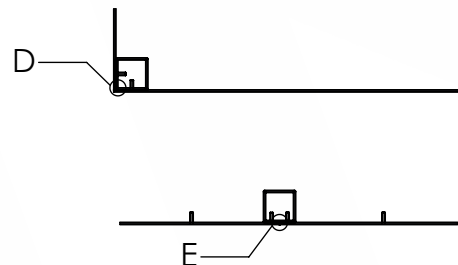

DETAIL D
SCALE 1 : 1

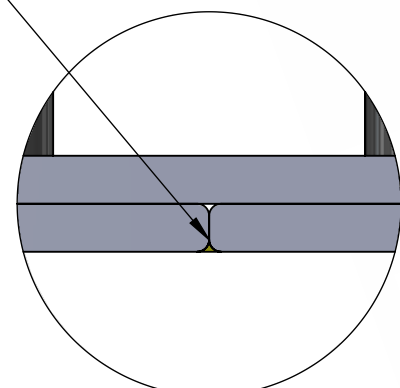

DETAIL E
SCALE 1 : 1



STEP: 8

IF PANELS WERE FLOATED ABOVE THE FRAMING MEMBERS USE A STRING LINE TO "TRUE" THE ENTIRE PERIMETER OF THE FRP. NO MORE THAN 3" ABOVE FRAMING AFTER TRIMMING

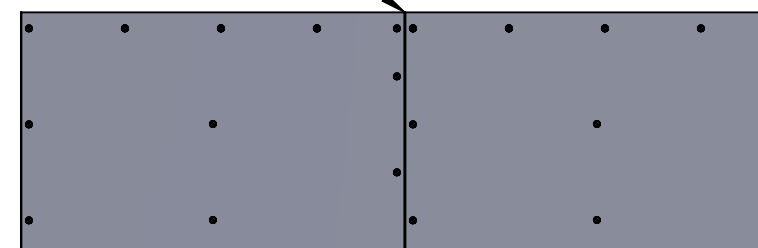
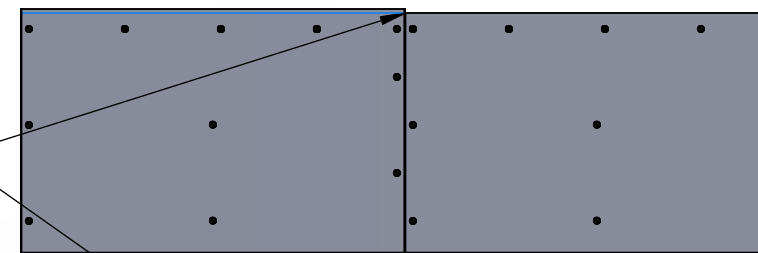

1990 OLIVERA RD SUITE B
CONCORD, CA 94520
www.TNHDev.com
PHONE: 800-916-1503

PROPRIETARY AND CONFIDENTIAL

THE INFORMATION CONTAINED IN THIS DRAWING IS THE SOLE PROPERTY OF TNH DEVELOPMENT, LLC. ANY REPRODUCTION IN PART OR AS A WHOLE WITHOUT THE WRITTEN PERMISSION OF TNH DEVELOPMENT, LLC. IS PROHIBITED.

DATE: DESIGNED: DRAFTER:

REVISIONS	
REV	DESCRIPTION

"CARRIER"

GLUE & SCREW INFO	"SITE NAME"
	SITE# XXXXXXX
	"JOB DESCRIPTION" "ADDRESS"

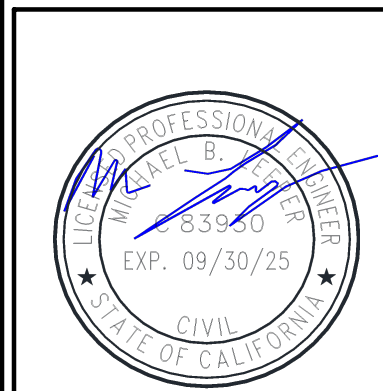

S5	REV
	A
	SHEET 7