

# Site manual

Resin decorative  
coverings

- Wallcrete Living
- Wallpaper<sup>®</sup> Living
- Patina<sup>®</sup> Living
- Stripe Living

**kerakoll**



## Contents

### **Resin decorative coverings**

|                   |    |
|-------------------|----|
| Wallcrete Living  | 06 |
| Wallpaper® Living | 18 |
| Patina® Living    | 28 |
| Stripe Living     | 40 |



# Resin decorative coverings

Wallcrete Living  
Wallpaper® Living  
Patina® Living  
Stripe Living

## Use

---

Decorative walls of domestic environments (living rooms, bedrooms, hallways and stairs) as well as commercial ones (showrooms, restaurants, shops and offices).

# Wallcrete Living

Water based resin covering with a coloured trowelled material texture.

The matt and monochromatic surface of Wallcrete is characterized by irregularities and textured details resulting from an exclusive hand-made processing that enhances the natural vibration of colours.



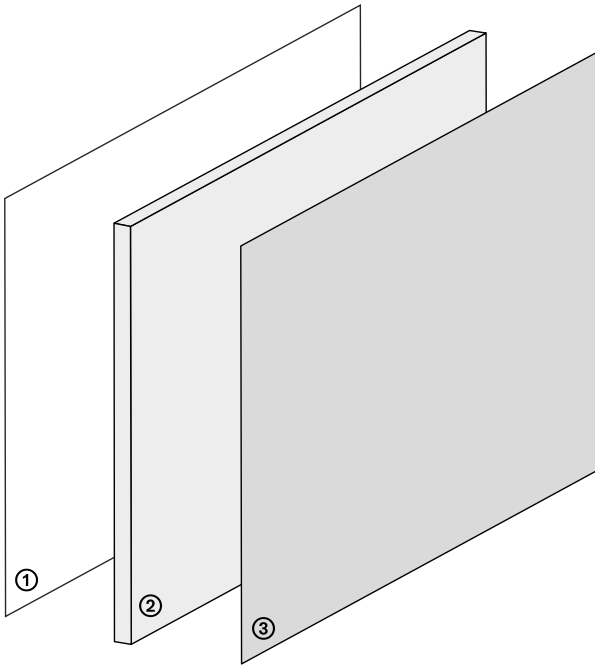

① Layer → Priming

**Universal Wall Primer**

② Layer → Skimming

**Wallcrete**

③ Layer → Coloured finish

**Decor Paint**

# ① Layer → Priming

## Preparation

### Warnings about substrates

- The substrates must be permanently dry and free from rising damp.
- Temperature range for application: from +10 °C to +30 °C.
- Relative environmental humidity: ≤ 75%.

### Suitable substrates

- Cement based finishing products, lime and gypsum.
- Substrates made with plasterboard and fibre-cement panels.
- Plywood and MDF panels.



## Universal Wall Primer

Water-based universal primer for walls.



### Products

Pack – 1 l - 5 l - 10 l



### Coverage

≈ 150 – 200 ml/m<sup>2</sup>

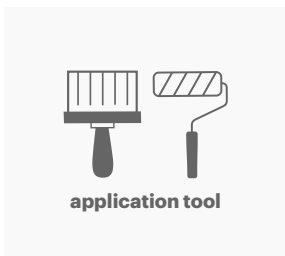

### Tools

Brush and roller

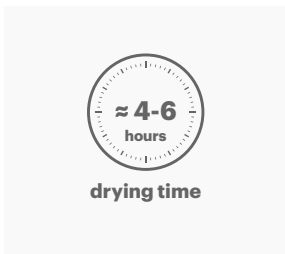

### Time

Waiting time for overlaying: ≈ 4 - 6 hours for the subsequent application of **Wallcrete**

# ② Layer → Skimming

## Preparation

### Ready-to-use

→ Remix the product inside the container to ensure the mixture is of an even consistency.

## Wallcrete

Texturizing base finishing coat for **Wallcrete Living** resin covering.



### Products

Pack – 5 kg - 15 kg



### Coverage

≈ 1.8 kg/m<sup>2</sup> for two coats



### Tools

Trowel 2 spreader

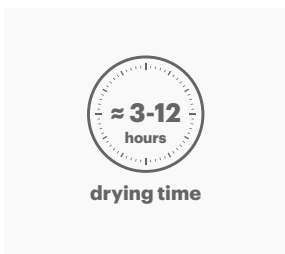

### Time

Once the material has hardened: ≈ 3 - 12 hours

## ② Layer → Skimming

Wallcrete



→ Apply the 1<sup>st</sup> coat of **Wallcrete** spreading the product with small and even strokes of the spreader over the entire surface.

Tip: a drop of water may be added in order to make the product more workable.



→ To speed up drying times (especially in damp environments and/or with little air circulation), the use of a fan is recommended.



Tip: in order to improve the visibility of the processing, Wallcrete in paste form can be coloured by adding a few drops of Decor Paint of the same shade as the final colour.



- Apply the 2<sup>nd</sup> coat once the material has hardened (3 - 12 hrs).
- The 2<sup>nd</sup> coat has the purpose to define the final texture of the surface; therefore, spread the product smoothing it out completely with small and even strokes of the spreader.

Tip: if crests or flashes are present, sand in order to remove them before applying the 2<sup>nd</sup> coat.

# ③ Layer → Coloured finish

## Preparation

### Ready-to-use

→ Remix the product inside the container to ensure the mixture is of an even consistency.

## Decor Paint

Water based decorative resin-paint with washable and wipeable matt-finish and high chromatic intensity.



### Products

Pack – 1.5 l - 4 l - 10 l



### Coverage

≈ 200 ml/m<sup>2</sup> for two coats

Dilution – max 5 - 10%

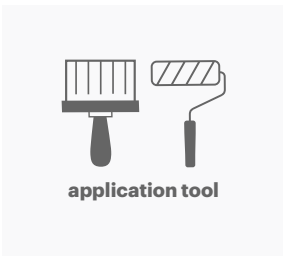

### Tools

Brush and roller

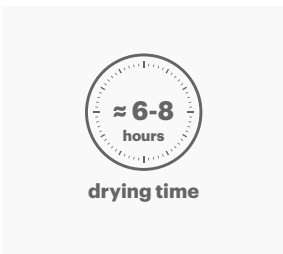

### Time

Waiting time between 1<sup>st</sup> and 2<sup>nd</sup> coat: ≥ 6 hours

### ③ Layer → Coloured finish

Decor Paint



- After 4 - 6 hours from the **Wallcrete** application, sand the surface with 80 - 120 grain sandpaper in order to remove any small imperfections and to make the surface smooth and pleasing to the touch.
- **Decor Paint** must be carefully applied with a roller over the whole surface in 2 coats, either pure or diluted to a maximum of 5 - 10%.  
Tip: proceed with shaping by passing over the laid film while it is still wet.





→ **Leave at least 6 hours between the first and second coats.**

Tip: in cases where different batches of coloured product are used, it is advisable to mix the various quantities together so as to avoid slight differences in tone.

# Wallpaper® Living

Water based resin covering with a coloured superflat smooth finish.

The matt and monochromatic surface of Wallpaper® is ultra-smooth and silky to the touch. Its essential charm creates a minimalist atmosphere of great elegance and formal purity.



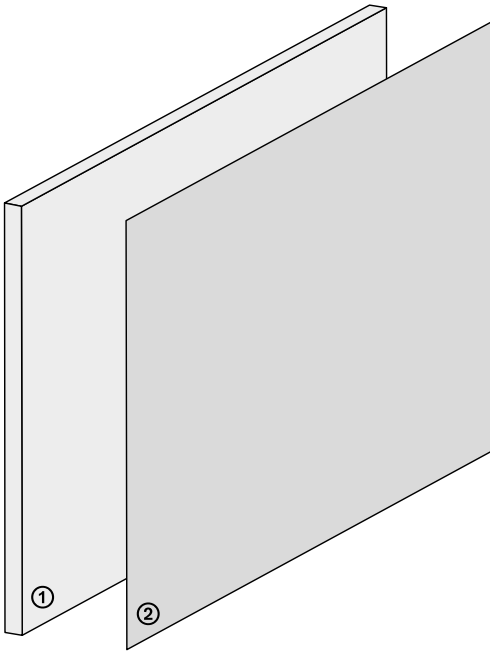

① Layer → Skimming

**Wallpaper® Living**

② Layer → Coloured finish

**Decor Paint**

# ① Layer → Skimming

## Preparation

### Warnings about substrates

- The substrates must be permanently dry and free from rising damp.
- Relative environmental humidity:  $\leq 75\%$ .

### Suitable substrates

- Cement based finishing products, lime and gypsum.
- Substrates made with panels in plasterboard.

### Warning

- Remix before use; the paste must be smooth, consistent and without lumps.

### Tip

- Porous substrates with a reduced level of cohesion must always be compact and absorbent; if this is not the case, they must be strengthened with **Universal Wall Primer**.

## Wallpaper® Living

Smooth base finishing coat for **Wallpaper® Living** resin covering.



### Products

Pack – 20 kg



### Coverage

On plasterboard or finishes with grain size  $\leq 0.5$  mm  $\approx 0.6 - 0.8$  kg/m<sup>2</sup>

On finishes with grain size  $\geq 0.5$  mm  $\approx 1.3 - 1.5$  kg/m<sup>2</sup>



### Tools

Trowel 2 spreader

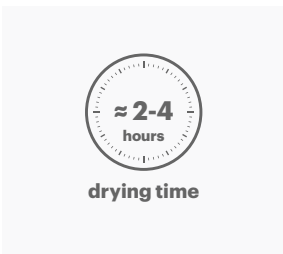

### Time

Waiting time between 1<sup>st</sup> and 2<sup>nd</sup> coat:  $\approx 2 - 4$  hours

Waiting time for **Decor Paint**:  $\approx 24 - 48$  hours

## ① Layer → Skimming

Wallpaper® Living



→ Apply the 1<sup>st</sup> coat of **Wallpaper® Living** smoothing the product on the surface in order to even and level it.

Tip: a drop of water may be added in order to make the product more workable.



→ Apply the product on the previous dry coat, until a perfectly even surface is achieved.

→ Before applying **Decor Paint**, check that the surface is perfectly even; if necessary, apply a further coat.

Tip: for a professional standard finishing coat, we recommend applying at least 3 coats.

If crests or flashes are present, sand in order to remove them before applying a further coat and before applying Decor Paint coloured finish.

# ② Layer → Coloured finish

## Preparation

### Ready-to-use

→ Remix the product inside the container to ensure the mixture is of an even consistency.



## Decor Paint

Water based decorative resin-paint with washable and wipeable matt-finish and high chromatic intensity.



### Products

Pack – 1.5 l - 4 l - 10 l



### Coverage

≈ 200 ml/m<sup>2</sup> for two coats

Dilution – max 5 - 10%

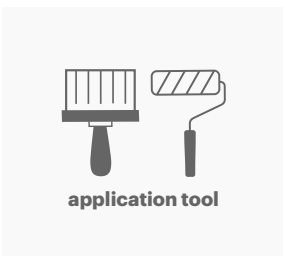

### Tools

Brush and roller

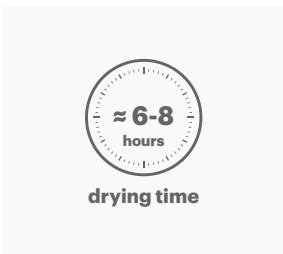

### Time

Waiting time between 1<sup>st</sup> and 2<sup>nd</sup> coat: ≥ 6 hours

## ② Layer → Coloured finish

Decor Paint



→ Before applying **Decor Paint**, sand the surface with 80 - 220-grain sandpaper in order to make the surface perfectly smooth and pleasing to the touch.



→ **Decor Paint** must be carefully applied with a roller over the whole surface in 2 coats, either pure or diluted to a maximum of 5 - 10%.  
Tip: proceed with shaping by passing over the laid film while it is still wet.



- Help yourself with a spotlight to create a grazing light flush with the wall, and be able to check the perfect evenness of the surface.
- If there are small imperfections, grout promptly with **Wallpaper®** before proceeding with the subsequent coats.



- **Leave at least 6 hours between the 1<sup>st</sup> and 2<sup>nd</sup> coats.**
- Tip: in cases where different lots of coloured product are used, it is advisable to mix the various quantities together so as to avoid slight differences in tone.

# Patina® Living

Water based resin covering with a delabré plaster texture and natural shaded finish.

The surface of Patina® is velvety to the touch and characterized by ripples and material vibrations resulting from the imperfections of hand-made processing.

The uneven colour and the unique effects in light reflection create a sophisticated sense of imperfection.



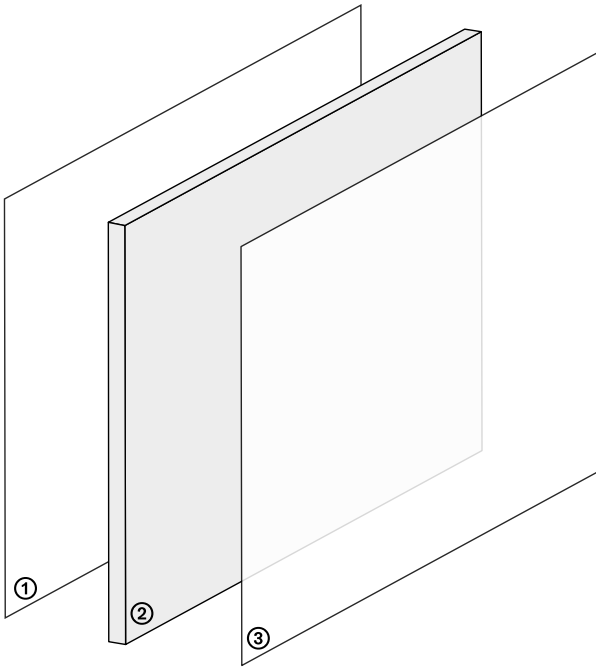

① Layer → Priming

**Universal Wall Primer**

② Layer → Skimming

**Patina®**

③ Layer → Impregnating protective product

**Finish**

# ① Layer → Priming

## Preparation

### Warnings about substrates

- The substrates must be permanently dry and free from rising damp.
- Temperature range for application: from +10 °C to +30 °C.
- Relative environmental humidity: ≤ 75%.

### Suitable substrates

- Cement based finishing products, lime and gypsum.
- Substrates made with plasterboard and fibre-cement panels.
- Plywood and MDF panels.

## Universal Wall Primer

Water based universal primer for walls.



### Products

Pack - 1 l - 5 l - 10 l



### Coverage

≈ 150 - 200 ml/m<sup>2</sup>

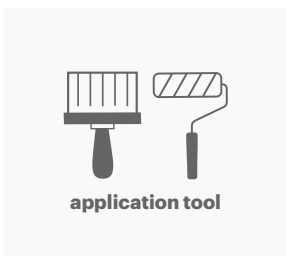

### Tools

Brush and roller

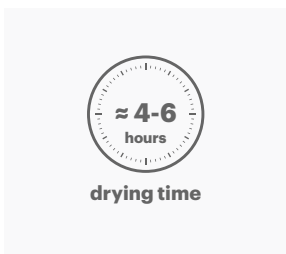

### Time

Waiting time for overlaying: ≈ 4 - 6 hours for the subsequent application of **Patina**<sup>®</sup>

# ② Layer → Skimming

## Preparation

### Ready-to-use

→ Remix the product inside the container to ensure the mixture is of an even consistency.



## Patina®

Coloured texturizing finishing coat for **Patina® Living** resin covering.



### Products

Pack – 15 kg



### Coverage

$\approx 1.8 \text{ kg/m}^2$  for two coats



### Tools

Trowel

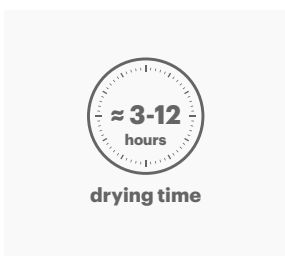

### Time

Once the material has hardened:  $\approx 3 - 12$  hours

## ② Layer → Skimming

Patina®



→ Apply the 1<sup>st</sup> coat of **Patina®** smoothing the product with small and even strokes of the spreader over the entire surface.

Tip: when applying, keep the spreader flat so as not to leave raised crests or notches.

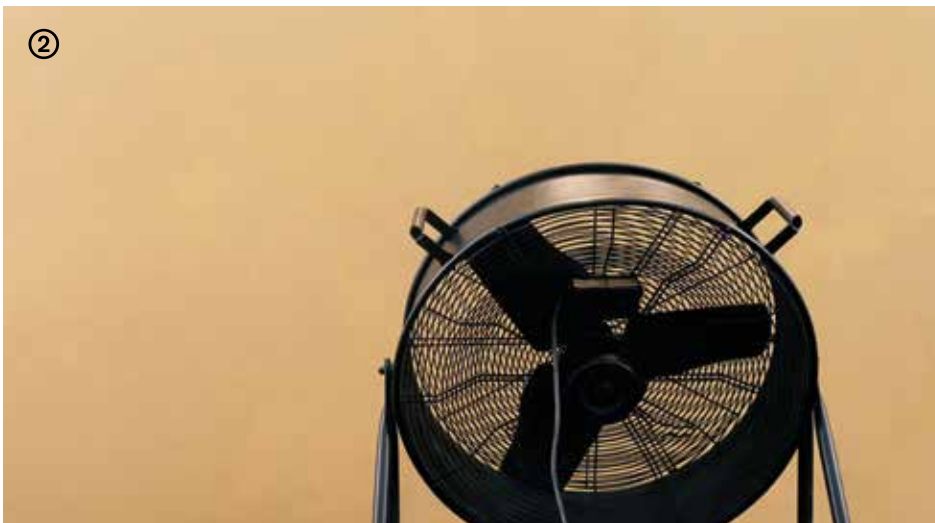

→ To speed up drying times (especially in damp environments and/or with little air circulation), the use of a fan is recommended.



→ Apply the 2<sup>nd</sup> coat once the material has hardened (3 - 12 hrs).  
Tip: if crests or flashes are present, sand in order to remove them before applying the 2<sup>nd</sup> coat. A drop of water may be added in order to make the product more workable.

# ③ Layer → Impregnating protective product

**Preparation**

**Ready-to-use**

→ Remix the product inside the container to ensure the mixture is of an even consistency.

## Finish

Protective water based impregnating product for **Patina® Living** resin covering.



### Products

Pack – 1.5 l



### Coverage

≈ 150 ml/m<sup>2</sup> for two coats

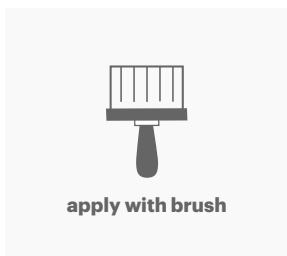

### Tools

Brush

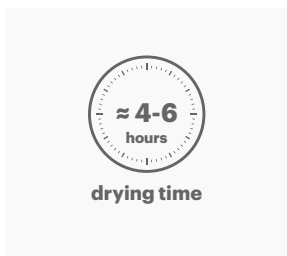

### Time

Waiting time between 1<sup>st</sup> and 2<sup>nd</sup> coat: ≈ 4 - 6 hours

### ③ Layer → Impregnating protective product

Finish



→ Once the coloured texturizing finishing coat **Patina**® has completely dried, apply the 1<sup>st</sup> coat of **Finish** by brush without sanding.

Tip: proceed with crossed strokes from the top downwards.



→ After 4 - 6 hours, sand the surface with 80 - 120-grain sandpaper in order to remove any small imperfections and to make the surface smooth and pleasing to the touch.



→ Remove any dust with a dry flat brush or a cotton cloth and then apply the 2<sup>nd</sup> coat of **Finish**.

# Stripe Living

Water based resin covering with coloured delabrè micro-lined texture.

The surface of Stripe Living is modelled by the expert hand of the craftsman, for a refined decorative effect, almost like a wallpaper with a precious material aspect.





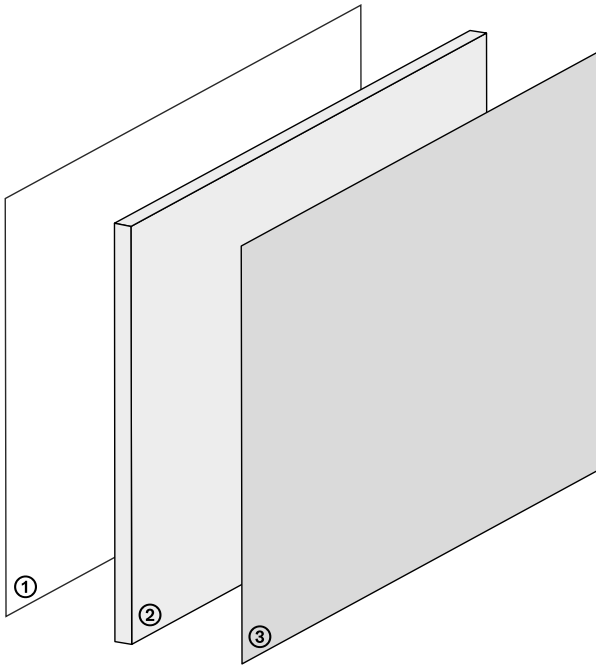

① Layer → Priming

**Universal Wall Primer**

② Layer → Texture

**Stripe**

③ Layer → Coloured finish

**Decor Paint**

# ① Layer → Priming

## Preparation

### Warnings about substrates

- The substrates must be permanently dry and free from rising damp.
- Temperature range for application: from +10 °C to +30 °C.
- Relative environmental humidity: ≤ 75%.

### Suitable substrates

- Cement based finishing products, lime and gypsum.
- Substrates made with plasterboard and fibre-cement panels.
- Plywood and MDF panels.

### Preparation of substrates

- In order to obtain the standardized effect, it is necessary to apply **Stripe** on a smooth and even surface.
- If necessary, smooth the substrates with **Wallpaper®** or **Wallpaper® Living**.

## Universal Wall Primer

Water based universal primer for walls.



### Products

Pack - 1 l - 5 l - 10 l



### Coverage

≈ 150 - 200 ml/m<sup>2</sup>

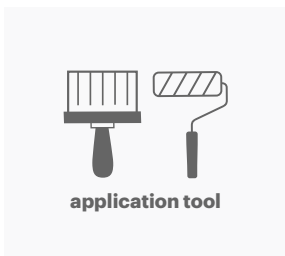

### Tools

Brush and roller

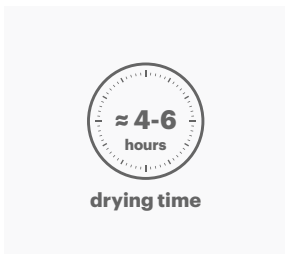

### Time

Waiting time for overlaying: ≈ 4 - 6 hours for the subsequent application of **Stripe**

# ② Layer → Texture

## Preparation

### Ready-to-use

→ Always remix **Stripe** before applying.

### Tip

→ Apply the product pure, not diluted.

## Stripe

Coloured base texturizing agent for **Stripe Living** resin covering.



### Products

Pack – 4 l - 10 l



### Coverage

≈ 700 ml/m<sup>2</sup> for two coats

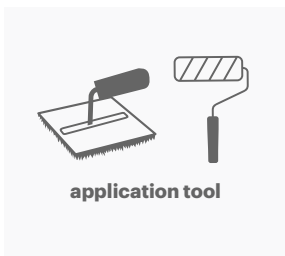

### Tools

Roller and stripe tool

The stripe tool mat can be easily removed for cleaning and to make it suitable for application in corners, niches, grooves, etc.

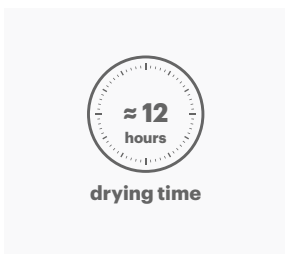

### Time

Waiting time between 1<sup>st</sup> and 2<sup>nd</sup> coat: ≥ 12 hours

Waiting time for overlayering: ≈ 12 hours

## ② Layer → Texture

### Stripe\_ Application with Ultrafine Lined and Textile effect



- Apply the 1<sup>st</sup> coat of the product pure (not diluted).
- Use a long-bristle roller, laying on the surface an abundant quantity of the product, approximately 400 ml/m<sup>2</sup> with a thickness of approximately 2 mm.
- Apply vertical strips (1 - 1.5 m wide) of **Stripe**, using the wet-on-wet method.



→ Pass over the wet strip with the Stripe tool while the product is still fresh, creating horizontal lines, making sure to keep the geometry parallel with the plane.



Tip: the use of a laser leveller pointed at the wall might be useful in order to keep the lines perfectly horizontal.

## ② Layer → Texture

Stripe



### **Application with Ultrafine Lined effect**

- Apply the 2<sup>nd</sup> coat of the product pure (not diluted), following the same procedure used for the application of the 1<sup>st</sup> coat.
- Pass over the wet strip with the Stripe tool, creating horizontal lines, making sure to keep the geometry parallel with the plane.





### **Application with Textile effect**

→ Apply the 2<sup>nd</sup> coat of the product pure (not diluted), following the same procedure used for the application of the 1<sup>st</sup> coat.

→ Pass over the wet stripe with the Stripe tool, creating vertical lines.

Tip: in case of areas presenting slightly accentuated lines, a subsequent coat of Stripe may be applied, even locally, blending the patch layer with the Stripe tool.

# ③ Layer → Coloured finish

## Preparation

### Ready-to-use

→ Remix the product inside the container to ensure the mixture is of an even consistency.

## Decor Paint

Water based decorative resin-paint with washable and wipeable matt-finish and high chromatic intensity.



### Products

Pack – 1.5 l - 4 l - 10 l



### Coverage

≈ 200 ml/m<sup>2</sup> for two coats

Dilution – max 5 - 10%

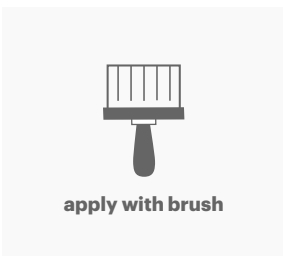

### Tools

Brush

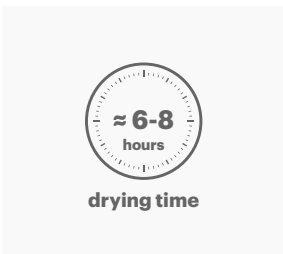

### Time

Waiting time between 1<sup>st</sup> and 2<sup>nd</sup> coat: ≥ 6 hours

### ③ Layer → Coloured finish

Decor Paint



→ Lightly sand by hand in order to remove any small flaws or lumps before applying **Decor Paint**.



→ **Decor Paint** must be applied over the whole surface, by brush, in one or two coats, either pure or diluted to a maximum of 5 - 10%, following the direction of the horizontal lines.



# Surfaces and Uses

## Surfaces

---

### Paints

Absolute Paint  
Decor Paint

---

### Resin-based coating materials

**Decorative coverings**  
Wallcrete Living  
Wallpaper® Living  
Patina® Living  
Stripe Living

### Technical coverings\*

Wallcrete  
Wallpaper®  
Patina®

---

### Microresina

Microresina®  
Microresina® Floor  
Microresina® Parquet

---

### Cementoresina

Cementoresina®  
Cementoresina® Wall

---

### Legno+Color

Legno+Color® S, M, L

---

### Finishes for external application

Outdoor Paint  
Outdoor Plaster

---

### Skirting board

Invisibile

---



## Use

---

### Walls and ceilings

Absolute Paint  
Decor Paint

---

### Decorative walls

Wallcrete Living  
Wallpaper® Living  
Patina® Living  
Stripe Living

---

### Technical walls\*

Wallcrete  
Wallpaper®  
Patina®  
Cementoresina® Wall

---

### Floors

Cementoresina®  
Legno+Color® S, M, L  
Microresina® Floor  
Microresina® Parquet

---

### Re-color\*\*

Microresina®

---

### External façades

Outdoor Paint  
Outdoor Plaster

\* Walls of bathrooms and kitchens.

\*\* Doors, internal and external fixtures, joinery and ceramic coverings.

N.B.

This Site manual has been drafted on the basis of the best technical and practical knowledge of Kerakoll S.p.A.

It is, however, a set of guides and information of a general nature that do not consider the real situations of individual structures; therefore, the coverage information is to be considered merely indicative.

Kerakoll does not intervene directly in the building site conditions, the specific design of the project, and the execution of the work; the information and guidelines mentioned here do not commit Kerakoll in any way.

The designer in charge is responsible for the entire structural design in accordance with Italian Ministerial Decree 17/01/2018 and its amendments or additions.

All rights reserved. © Kerakoll. All rights to the content of this publication are reserved in accordance with applicable law.

The duplication, publication, and distribution, in full or in part, of all material contained herein, are expressly forbidden without written authorization. Additions and/or amendments to this information may be made over time by KERAKOLL Spa; for the latest version, see [www.kerakoll.com](http://www.kerakoll.com).

KERAKOLL Spa shall therefore be liable for the validity, accuracy and updating of information provided only when taken directly from its institutional website. For information on the product safety data, refer to the corresponding sheets provided in accordance with the law along with the health labelling on the packaging. Finally, it is advisable to perform a preliminary test of each product to verify its suitability for your purposes.

Kerakoll Spa  
via dell'Artigianato 9  
41049 Sassuolo (MO) Italy  
T +39 0536 816 511  
info@kerakoll.com

Kerakoll Brera Studio  
via Solferino 16  
20121 Milano (MI) Italy  
T +39 02 620 867 81

**kerakoll**

[kerakoll.com](http://kerakoll.com)