

Vintage 6SL7 Phono Stage (MM / MC)

Assembly and Setup Manual



TAVISH DESIGN, LLC

Made in U.S.A.

TABLE OF CONTENTS

1. Introduction & Quick Start	2
2. Safety Considerations	3
3. Assembly	4
4. Setup & Operation	12
4.1. Initial Setup	
4.2. Operation	
4.3. Tube Replacement	
5. Technical Information	16
5.1. Specifications	
5.2. Schematics	
5.3. Parts Placement Diagram	
5.4. Parts Lists	
6. Warranty and Service	29
7. Do-It-Yourself Guidance (FAQ)	30
8. Design Changes With Release 2.1	32
9. Copyright, Trademark, and Disclaimers	32

Manual Release 2.3a (17 February 2020)

1 INTRODUCTION AND QUICK START

Thanks for buying the Vintage 6SL7 Phono Stage!

Tavish Design’s Vintage 6SL7 Phono Stage is a passively-equalized, two-gain-stage design using the 6SL7 octal dual triode, a vacuum tube first introduced (by RCA) in 1941, and one which has remained popular with audio enthusiasts ever since. And, the basic circuit topology employed in our Vintage Phono Stage has also remained popular for decades. The reason for the endurance of this straight-forward topology is simple: with appropriate updates, it is very difficult to beat without going to elaborate multi-tube circuits. In fact, this simple phono stage outperforms many (if not most) high-end products.

Vacuum tubes present some unique safety considerations, so please take time to look over the safety considerations in Section 2.

Kit assembly instructions begin in Section 3. If you purchased the Vintage 6SL7 Phono Stage as an assembled unit, please see the Quick Start instructions below.

Feel free to contact Tavish Design if you have any questions (info@tavishdesign.com).

Quick Start

1. Install the tubes. See Section 4 if you haven’t done this before.

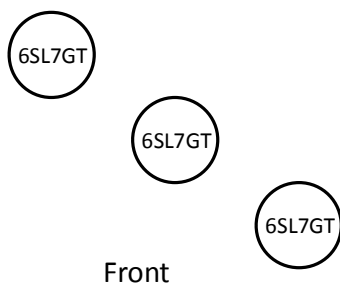

2. Connect your turntable to either the Moving Magnet (MM) or Moving Coil (MC) input and set the rear panel toggle switch to the corresponding position. Default settings for the Vintage Phono Stage should work well with most MM and low-output MC cartridges. You can customize cartridge loading, see Section 4.

If you have a high-output MC cartridge, the MM input is probably the best one to use, but it depends on your cartridge output level, and you may want to adjust the internal cartridge loading and gain settings. See Section 4.

Be sure to connect the ground post on the back of the phono stage to the ground post on your turntable.

3. The phono stage takes 30 – 40 seconds to warm up, as indicated by the blue “Ready” LED on the front panel. The phono stage will not pass signal until then. Turn down your volume control the first time you play an LP, until you are familiar with the appropriate volume setting.

2 SAFETY

1. **To avoid the risk of electric shock, do not operate the amplifier without the top cover in place. This amplifier uses high voltages internally which could cause an electrical shock, possibly resulting in injury or death. Lethal voltages can remain in the electronics after the unit is unplugged.** Refer servicing to Tavish Design, LLC. If the unit must be opened for servicing, unplug it and wait at least 10 minutes for internal capacitors to discharge.
2. **Do not operate the amplifier without the vacuum tubes in place.** Removal of the vacuum tubes exposes internal circuitry to contact and presents a shock hazard. This hazard is similar to removing a light bulb from its socket.
3. **Do not allow liquids (such as from a spilled drink or flower vase) to run into the amplifier,** as this can damage the amplifier or create an electric shock hazard. Do not operate outdoors or in wet areas. Do not allow rain to enter the amplifier (by placing the unit next to an open window, for instance).
4. **A broken or improperly seated vacuum tube can cause electric shock.** Do not operate the amplifier if any vacuum tubes have broken glass shells. Align the tubes if any are leaning or not fully seated, prior to operating the amplifier. Vacuum tubes get hot, so allow them to cool before handling.
5. **To avoid electric shock, do not insert thin metal objects between the vacuum tubes and the cover, or allow children to do so.** A metal object inserted into the amplifier could possibly contact high voltages present internally. This hazard is similar to that of sticking a pin or thin screwdriver into an electrical outlet.
6. **Keep out of reach of children.** A high shelf or table is better than a low one, if children are present.

3 ASSEMBLY

Warning: This amplifier uses high voltages which could cause an electrical shock, possibly resulting in injury or death. Therefore, these assembly instructions are intended for electronics technicians (or those with equivalent skills) having experience with high-voltage electronics. The usual safety procedures required when working with high voltages must be followed, and they are described only briefly in these instructions. If you are unfamiliar with these procedures, you should not attempt assembly. Please read through these instructions before beginning assembly. If you are in doubt about your ability to safely and successfully assemble the kit, please send it back, or first get some experience with other electronics kits. No liability is assumed by Tavish Design, LLC. The ARRL Handbook for Radio Amateurs¹ has a useful chapter on electrical safety.

Kit assembly requires a soldering iron with a fine tip and a digital multimeter (DMM), along with other normal electronics workshop tools.

Unpack the box and verify the following items:

Quantity	Item
1	Printed circuit board (4 JFETs are pre-installed on the PCB in the complete kit)
1	Enclosure
1	Decorative flange
1	Wall transformer
1	Bag of 58 metal film resistors
1	Bag of 27 carbon film or metal oxide resistors, and trimmers
1	Bag of 20 electrolytic capacitors
1	Bag of 19 film capacitors
1	Bag of 25 diodes, transistors, and ICs (not including 4 JFETs, which are pre-installed)
1	Bag of 19 miscellaneous PCB-mounted components
3	Tube sockets
1	Bag of hardware and chassis-mounted components, including switch and panel LEDs
3	Vacuum tubes (Sovtek 6H9C/6SL7GT)
1	PC mounted toroidal transformer

Detailed parts lists are included in tables 5.2 – 5.6. Use the schematic, parts lists, and parts placement diagram in section 5 to identify the correct location for parts.

¹ <http://www.arrl.org/shop/ARRL-Handbook-2015-Softcover-Edition/>

Step-by-step Instructions:

1. The surface mount JFETs are supplied pre-installed with the complete kit. If you purchased the blank PCB, install the JFETs first. The 2SK209 are marked “XL” and the MMBFJ270 are marked “61S”. Melt a small amount of solder on one of the pads. Then, holding the FET with a pair of tweezers, re-melt the solder and place one leg of the JFET in the molten solder. Solder the other two legs, then re-melt the solder for the first leg. Inspect the installation with a magnifying glass to verify your solder joints.
2. Install the tube sockets. Align the socket’s index slot with the marking on the PCB, as show in Photo 3.1. Double check the index alignment and make sure the sockets are fully seated against the top of the PCB before soldering all pins.

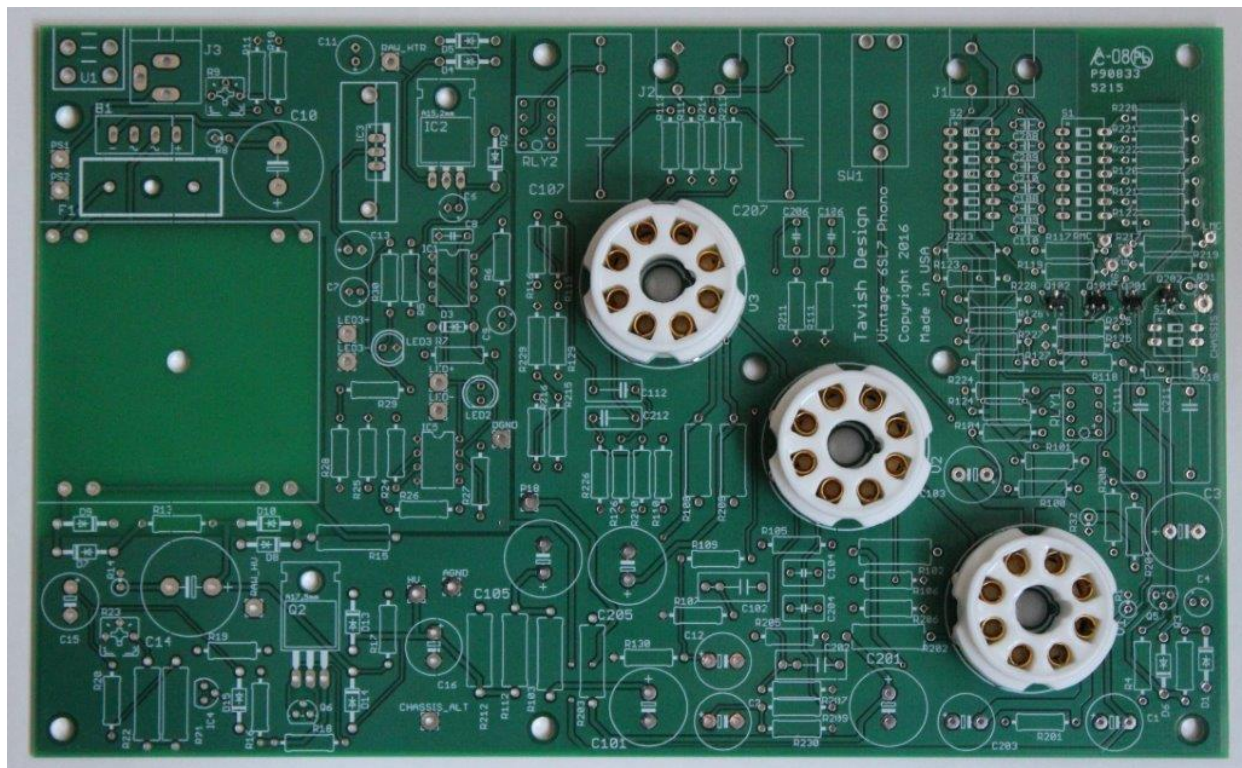

Photo 3.1: PCB after step 2. Please note that this photo was taken prior to design revisions. Photos 3.2 through 3.6 reflect the current PCB.

3. Install all resistors. Refer to <http://www.resistorguide.com/resistor-color-code/> or https://en.wikipedia.org/wiki/Electronic_color_code if you need help reading the color code on 1% resistors. It can be a good idea to place all the resistors on the PCB before soldering any of them, to be sure you get them all in the right location. Don't forget the jumpers R1, R8, R14, R31, and R32: they are used to interconnect the separate ground domains on the PCB.

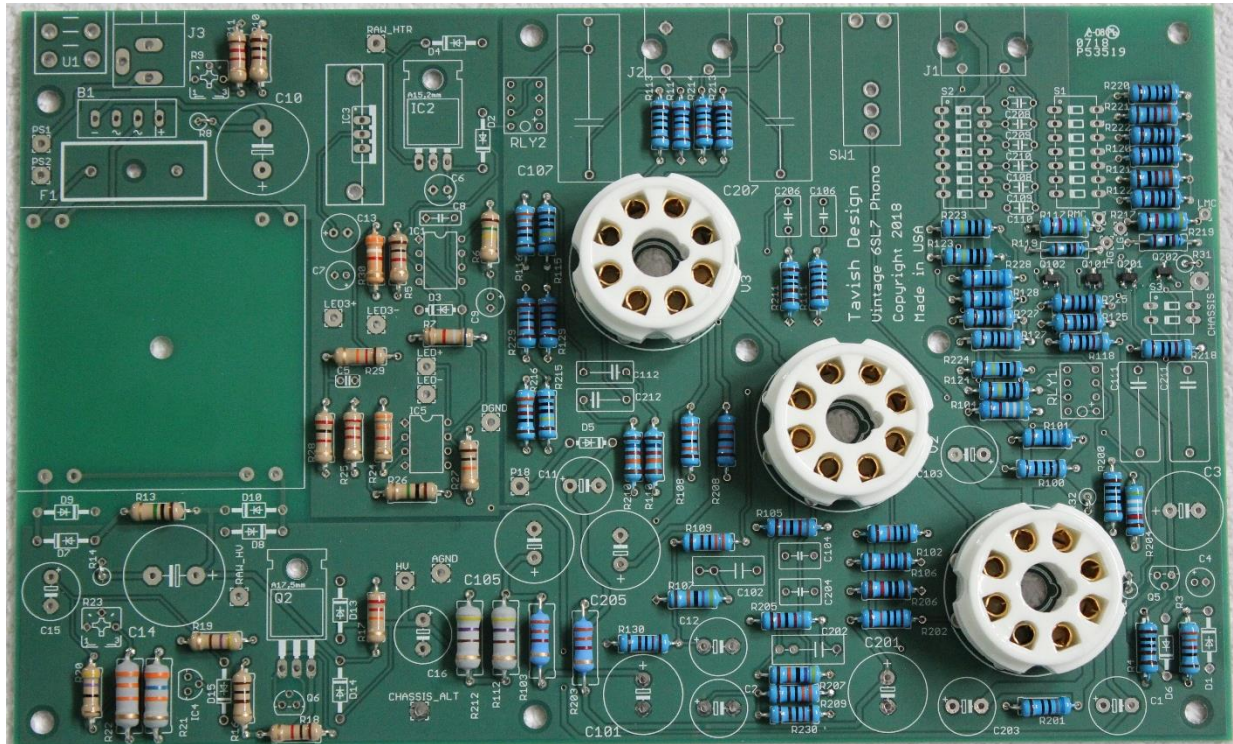

Photo 3.2: PCB after step 3.

4. Install Q2 and IC2-IC3 using a 3/8" #4-40 screw, flat washer, split washer, and nut to mount Q2 and IC2 (no flat washer needed for IC2) to the PCB before soldering. IC3 slides into heatsink HS1 and mounts upright.
5. Install D1 and D13 Zener diodes.
6. Install D7-D10 fast recovery diodes.
7. Install D3 Schottky diode.
8. Install D14-D15 1N4007.
9. Install D2, D4-D6 1N4002.

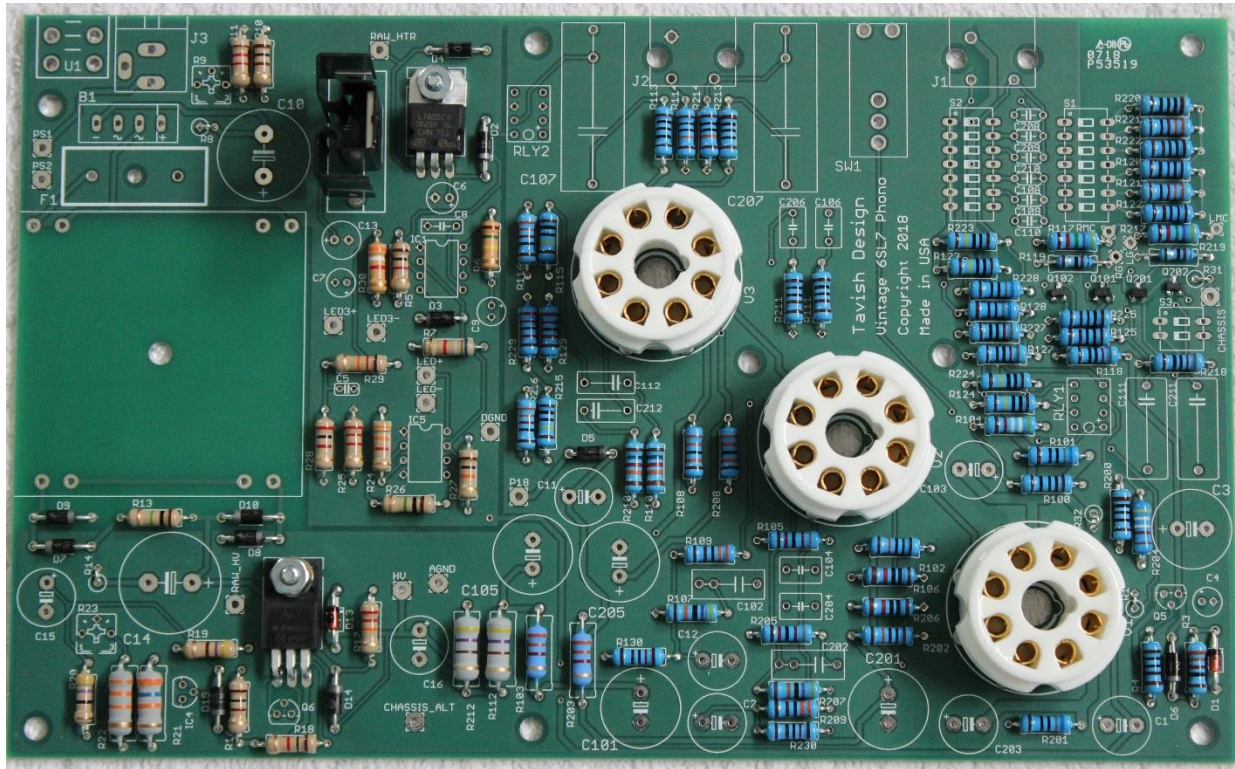

Photo 3.3: PCB after step 9.

10. Install trimmers R9 (500 Ω) and R23 (10 k Ω).
11. Install DIP sockets, noting that they have a polarity as marked on the PCB.
12. Install RLY1-RLY2, noting that they have a polarity as marked on the PCB.
13. Install the three PCB test points, a black one in the AGND pad, a red one in the HV pad, and a yellow one in the P18 pad.
14. Install the rest of the small components, including transistors and capacitors, but not those components that mount to the rear panel. Note the polarity of electrolytic capacitors and also make sure that they are fully seated against the PCB.

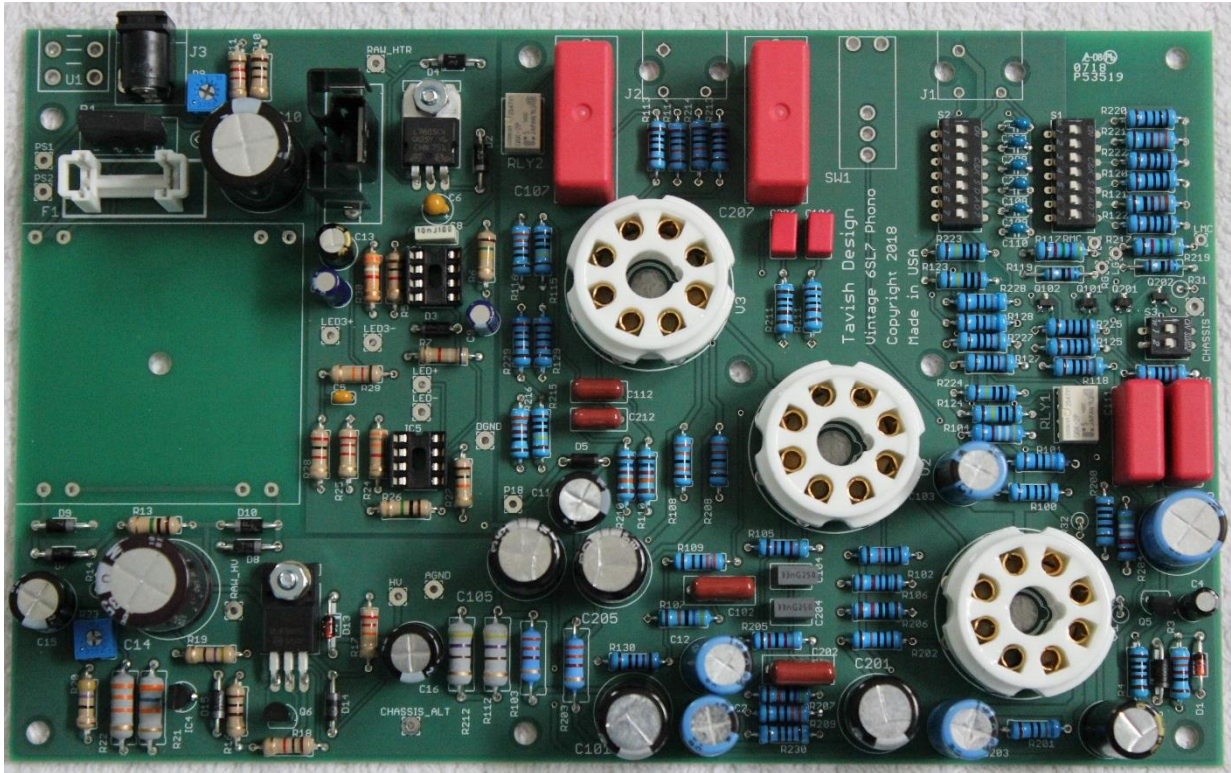

Photo 3.4: PCB after step 14.

15. Install J1-J3, SW1, and U1. For J1-J2, remove the chrome cover to expose the black insulator underneath before installing. This prevents the signal ground from shorting to the chassis (they must be isolated to prevent ground loops). See photo 3.5 below. Solder only one leg of each component, making sure they are seated against the PCB, then test fit the PCB in the enclosure. Adjust the position of the rear panel components if needed and solder fully in place.

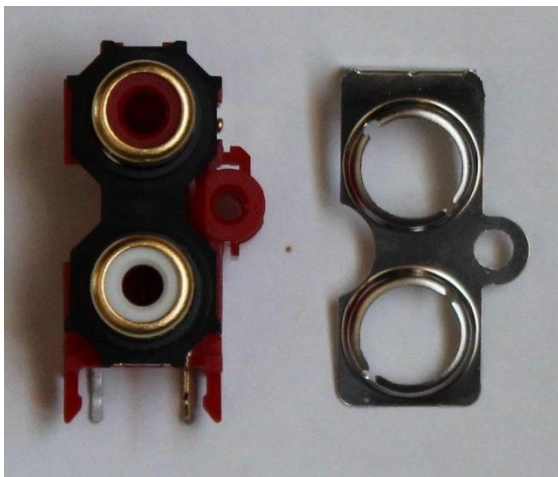

Photo 3.5: Switchcraft RCA connectors with chrome cover removed.

16. Prepare a 22ga. wire 2¼" (7 cm) long to connect the PCB wirepad CHASSIS to the rear panel ground post, using the ¼-20 ground terminal. Prepare a 22 ga. twisted pair 5½" (14 cm) long to connect the wirepads PS1 and PS2 to the front panel rocker switch, using 0.187" quick connect terminals.
17. Prepare a 24 ga. red/black twisted pair 3" (7.5 cm) long with one red wire connected to the RMC pad and one black wire connected to the RG pad. The other end will be trimmed to length later. Prepare a 24 ga. white/black twisted pair 3" long with one white wire connected to the LMC pad and one black wire connected to the LG pad. The other end will be trimmed to length later.
18. Install the power transformer using a 3/8" #6-32 screw, nylon flat washer, and #6-32 split washer, and solder in place.
19. Install IC1 and IC5, and the fuse.
20. Install the eight ¼" long nylon hex spacers on the bottom of the PCB, using #6-32 nylon hex nuts on the top of the PCB.

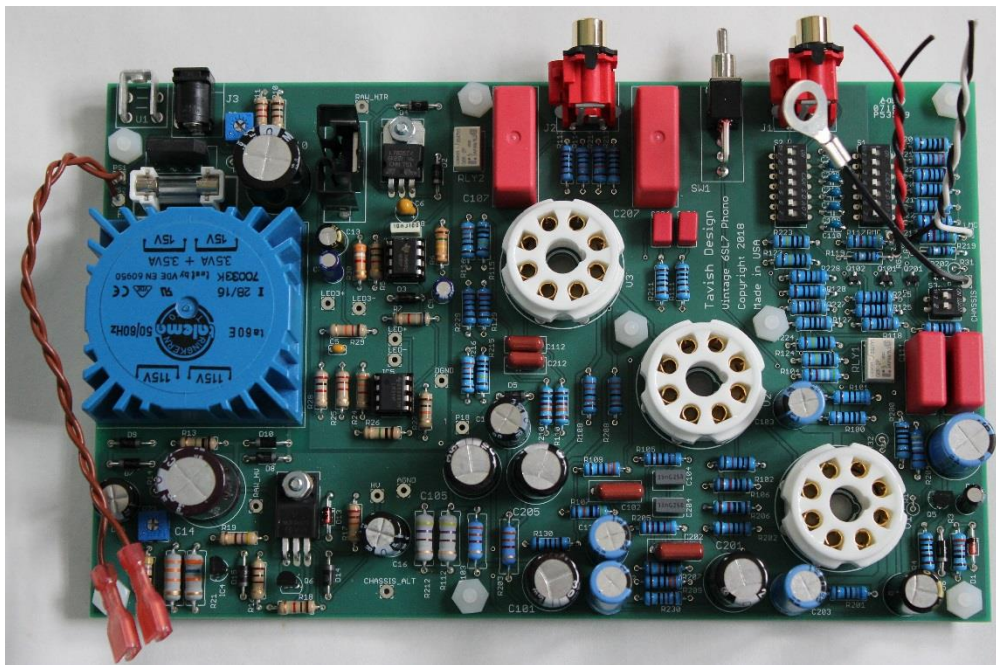

Photo 3.6: Completed PCB after step 20.

21. Double check that you have installed the components into their correct locations, and in the appropriate orientation, according to photo 3.6 above. Check that all PCB connections have been soldered. Set S1-S3 into their "factory default" positions according to tables 4.1 – 4.3 below and photo 3.8 below.
22. Install the PCB into the enclosure base using eight ¼" nylon screws from the bottom, one #6-32 black oxide pan head screw from the back, and two #3-24 plastite screws for the RCA jacks.
23. Install 4 rubber feet and the serial number sticker on the bottom of the unit.
24. Install the white RCA jack in the lower chassis hole for the moving coil input. Make sure it is insulated from the chassis using the nylon shoulder washer and flat washer. Connect the white/black twisted pair (white to the center signal terminal), keeping the wires as short as

possible and twisted as tightly as possible. Bend the ground lug toward body of the connector as shown in the assembly detail in photo 3.7.

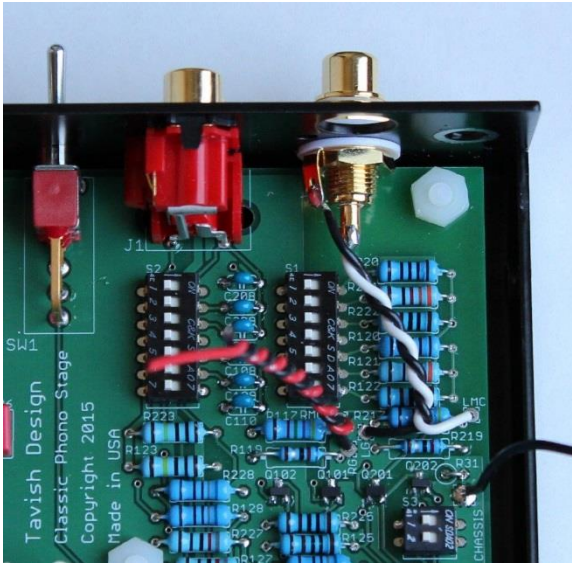

Photo 3.7: Connector wiring assembly detail.

25. In a similar manner, install and wire the red RCA jack in the upper chassis hole for the moving coil input (red to the center signal terminal).
26. Install and connect the ground post.
27. Install and connect the rocker switch.
28. Install the front panel LEDs, connecting the wires from the green LED to the "LED3" pads and the wires from the blue LED to the "LED" pads, red to the (+) pad and black to the (-) pad.
29. Install the decorative flange to the top of the enclosure using 1/4" #6-32 pan head screws and split washers.

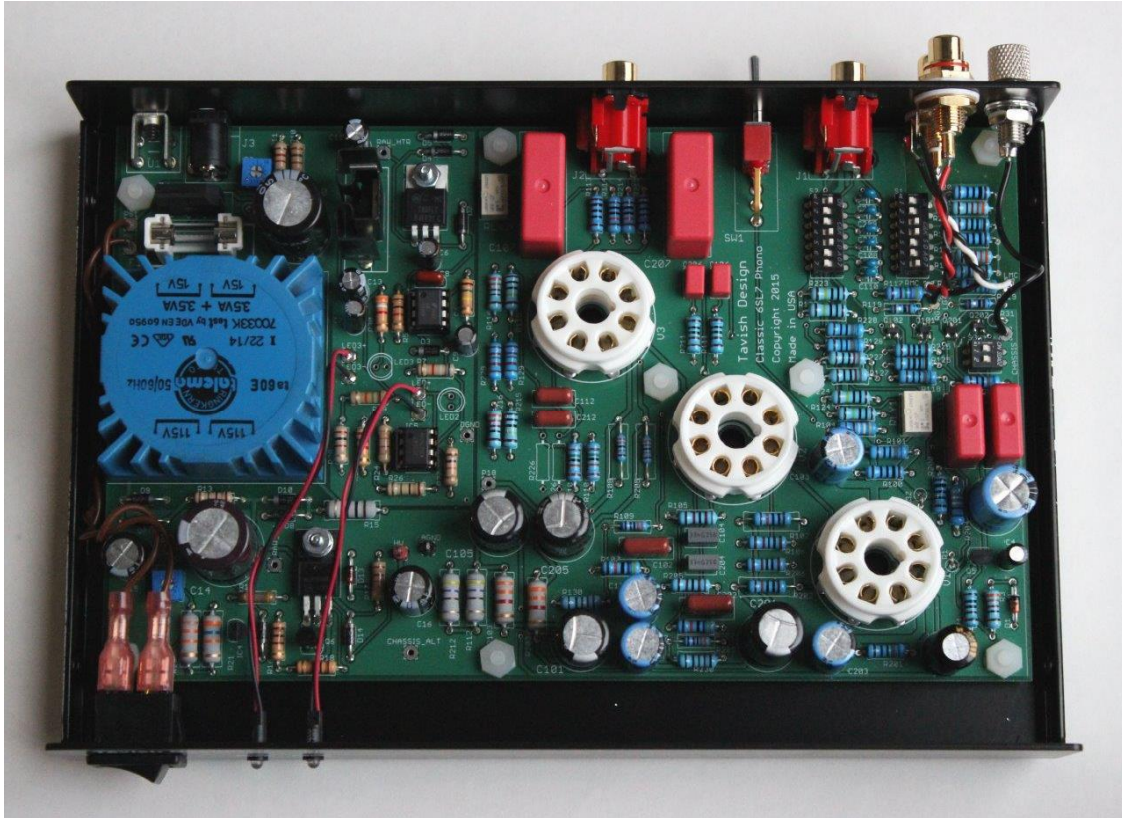

Photo 3.8: Completed phono stage after step 29.

30. Install the tubes (see section 4.1 below). Connect the negative lead of your voltmeter to the black PCB test point installed at the AGND pad. Connect the positive lead of your voltmeter to the P18 pad using the yellow PCB test point installed there. Observing appropriate high voltage safety procedures (such as keeping one hand in your pocket while the unit is powered on), plug in the wall transformer and switch the unit on. Measure the voltage at the P18 pad and adjust trimmer R9 for +18.6 V. Turn off the power and wait 10 minutes for the capacitors to discharge.
31. Connect the positive lead of your voltmeter to the HV pad using the red test point installed there. Measure the voltage at the HV pad and adjust trimmer R23 for +210 V. Turn off the power and wait 10 minutes for the capacitors to discharge.
32. Install the High Voltage sticker on the top of the transformer.
33. Install the cover using four ¼" #6-32 black oxide flat head screws (which are shipped installed in the enclosure). This completes assembly.

4 SETUP

4.1 INITIAL SETUP

Setup consists of installing the tubes (if needed), selecting the Moving Magnet (MM) or Moving Coil (MC) input, and setting the cartridge loading and MC gain (if needed). The factory settings for these should work well with most MM cartridges, and with low-output MC cartridges, so you might not need to adjust anything.

Installing the Tubes

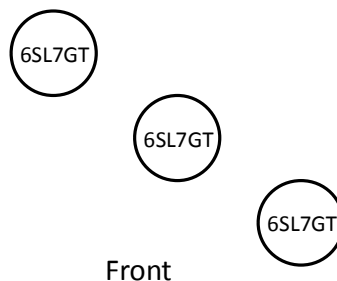

Fig. 4.1: Tube positions.

Note the tube positions above. To install the tubes, carefully align the tube's center index key with the socket and push down, gently rocking the tube slightly from side-to-side to ease the pins into the socket. Never twist or force the tube; the glass shell is easy to break if the pins are bent. The tubes are much easier to remove if the cover is removed first. Before removing the cover, unplug the unit and wait 10 minutes for the internal capacitors to discharge. Remove the cover by removing 4 screws.

Moving Magnet or Moving Coil Input

MM cartridges connect to the MM input (obviously), and low-output MC cartridges connect to the MC input.

In general, we recommend that high-output MC cartridges with an output >2 mV be connected to the MM input. We recommend that high-output MC cartridges with outputs <2 mV be connected to the MC input, with low gain setting, as described below. However, almost all high-output MC cartridges can also connect to the MM input if you prefer (and if there is enough gain for your system).

The MM or MC input is selected with SW1 on the back. To avoid a loud transient, turn the volume control on your amplifier to minimum before adjusting the position of SW1 or connecting or disconnecting cables. Be sure to connect the ground post on the back of the phono stage to the ground post on your turntable.

Cartridge Loading and Moving Coil Gain

Cartridge loading and the MC gain setting are set with internal DIP switches. The factory settings for these should work well with most MM cartridges, and with low-output MC cartridges. To select other settings, unplug the unit and wait 10 minutes for the internal capacitors to discharge. Remove the cover by removing 4 screws. Note the positions of DIP switches S1 – S3 as shown in Fig. 4.2 below. The tables 4.1 to 4.3 below show the switch positions to select other MC gain and cartridge load settings. Table 4.4 gives suggested settings for some popular cartridges. These are only a starting point. Follow your cartridge manufacturer’s recommendations, or select the loading to suit your preference. In selecting the capacitive load for a MM cartridge, note that the cables connecting your turntable to the phono stage have approximately 30 – 35 pF per foot, so a 3 foot cable contributes 100 pF of capacitance to cartridge loading.

Replace the cover after setting the cartridge loading and gain switches. To avoid a risk of electric shock, never operate the unit with the cover removed.

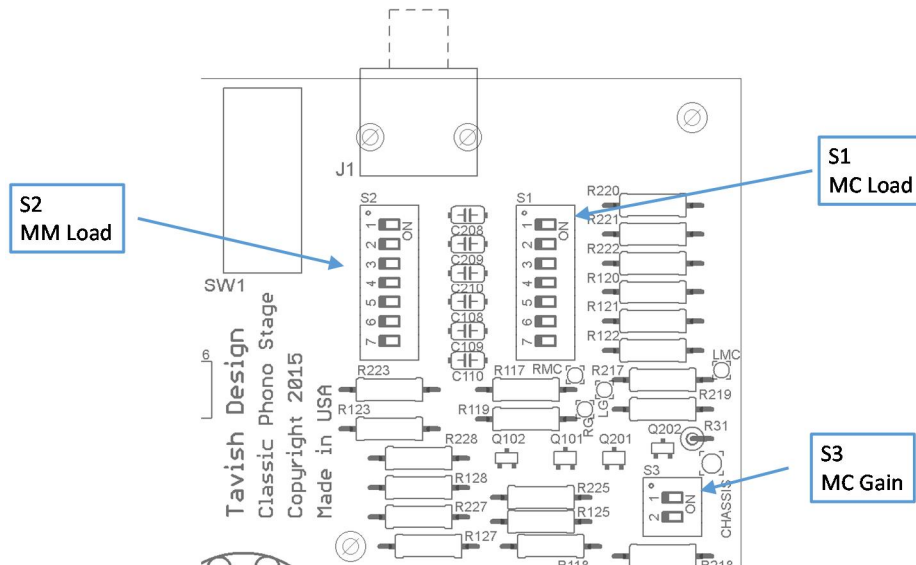

Fig. 4.2: Switch positions for setting MC Gain (S3), MC load (S2), and MM load (S1). For each switch, LEFT = OFF = 0, and RIGHT = ON = 1.

MC Gain Setting (S3)	S3 Positions (1 – 2)	OFF = 0, ON = 1
High (61 dB)	00	Factory Default
Low (53 dB)	11	

Table 4.1: MC Gain Settings.

MM Load Setting (S2)	S2 Positions (1 – 7) OFF = 0, ON = 1
No added capacitance	0001000
47 pF	1001100 Factory Default
100 pF	0101010
147 pF	1101110
180 pF	0011001
227 pF	1011101
280 pF	0111011
327 pF	1111111

Table 4.2: MM Load Settings.

MC Load Setting (S1)	S1 Positions (1 – 7) OFF = 0, ON = 1
47.5 k Ω	0001000
1 k Ω	0011001 Factory Setting
330 Ω	0101010
250 Ω	0111011
100 Ω	1001100
91 Ω	1011101
77 Ω	1101110
71 Ω	1111111

Table 4.3: MC Load Settings.

Cartridge Type	Example	Reference Output	Input	MC Gain Setting (S3: 1 – 2)	MM Load (S2: 1 – 7)	MC Load (S1: 1 – 7)
MM	AT95e	3.5 mV	MM	N/A	47 pF 1001100	N/A
MM	Ortofon 2M	5.5 mV	MM	N/A	47 pF 1001100	N/A
Low-Output MC	Denon DL103	0.35 mV	MC	High (00)	N/A	1 k Ω 0011001
Low-Output MC	Ortofon Quintet Red	0.5 mV	MC	High (00)	N/A	330 Ω 0101010
Hi-Output MC	Denon DL110	1.6 mV	MC	Low (11)	N/A	47.5 k Ω 0001000
Hi-Output MC	Sumiko Blue Point	2.5 mV	MM	N/A	No added C 0001000	N/A

Table 4.4: Suggested settings for popular cartridges. Note that the first three rows use the factory default settings.

4.2 OPERATION

If you removed the cover to adjust to set the cartridge loading and gain switches, you must replace it before operating the unit. To avoid a risk of electric shock, never operate the unit with the cover removed.

When the unit is switched on, it goes through a 40 second warmup sequence before the blue “ready” LED turns on. The phono stage will not pass signal until the blue “ready” LED is on. Before playing an LP, turn down the volume control on your amplifier until you are familiar with the required gain setting.

4.3 TUBE REPLACEMENT AND SUBSTITUTION

Vacuum tubes last much longer than most people realize, and although the lifetime of any particular tube is impossible to predict, hopefully it should be many years before any tube replacement is necessary. Replace tubes with the same type: only 6SL7GT tubes can be used in the phono stage. In particular, many people confuse the 6SL7 with the 6SN7. Unfortunately, the 6SN7 cannot be used in any position in the phono stage.

The unit is normally supplied with either Sovtek 6H9C/6SL7GT or Tung Sol Reissue 6SL7GT tubes. It is also OK to use new, old-stock (NOS) 6SL7GT tubes in the phono stage, although they do tend to be noisier, so you should be aware of potentially higher noise if you do use them. Noise is primarily an issue with the input tube (the right front tube). The noise levels in the electronics are well below the surface noise on vinyl LPs, so you may wish to choose the input tube by other criteria as well.

The tubes are much easier to remove if the cover is removed first. Before removing the cover, unplug the unit and wait 10 minutes for the internal capacitors to discharge. Remove the cover by removing 4 screws on the sides of the enclosure. **If you do remove the cover, you must replace it before operating the unit. To avoid a risk of electric shock, never operate the unit with the cover removed.**

5 TECHNICAL INFORMATION

Parameter	Specification
Gain	41 dB Moving Magnet 53 dB High-Output Moving Coil 61 dB Low-Output Moving Coil
RIAA Equalization Accuracy	±0.5 dB, 25 Hz – 20 kHz
Signal-to-noise ratio (A-weighted)	>79 dBA ref. 5 mV @ 1kHz, Moving Magnet >79 dBA ref. 1.25 mV @ 1kHz, High-Output Moving Coil >76 dBA ref. 0.5 mV @ 1kHz, Low-Output Moving Coil
Reference Output Level	560 mV RMS (-2.8 dBu)
Total Harmonic Distortion	<0.02% at reference output level into 22 kΩ, 1 kHz
Output Overload (defined as 1% THD level)	>14 V RMS into 22 kΩ at 1 kHz (31dB overload margin)
Input Impedance, Moving Magnet	47.5 kΩ in parallel with fixed capacitance of approximately 85pF and adjustable capacitance of: 0pF, 47pF, 100pF, 147pF, 180pF, 227pF, 280pF, or 327pF
Input Impedance, Moving Coil	Adjustable: 47.5 kΩ, 1 kΩ, 330 Ω, 250 Ω, 100 Ω, 91 Ω, 77Ω, or 71 Ω
Output Impedance	<1000 Ω at 1 kHz
Suggested Load Impedance	≥10 kΩ ≤1800 pF (up to 60 feet of coaxial cable)
Power	18 W, 120 VAC, 60 Hz
Size	9" wide x 6" deep x 1.5" high (4" high to top of tube guard)
Weight	3.5 pounds (6 pounds shipping weight)

Table 5.1: Phono stage performance. Measurements are taken with Sovtek 6H9C/6SL7GT tubes, as supplied.

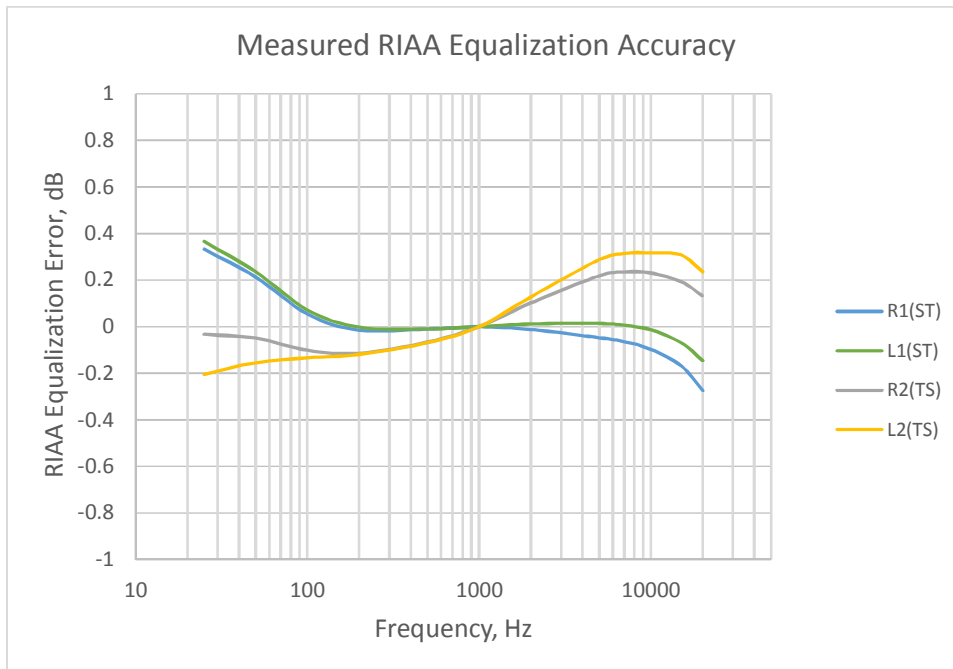

Fig. 5.1: Typical measured RIAA equalization error with both Sovtek 6H9C/6SL7GT (ST) and Tung Sol Reissue 6SL7GT (TS) tubes, left and right channels. Error is <0.5 dB from 25 Hz – 20 kHz for all curves.

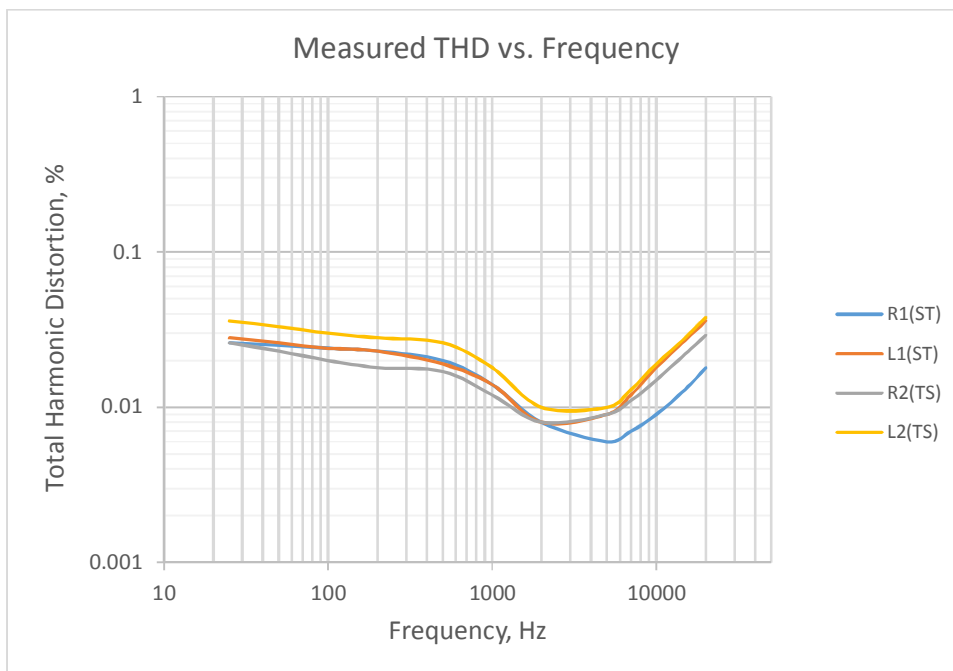
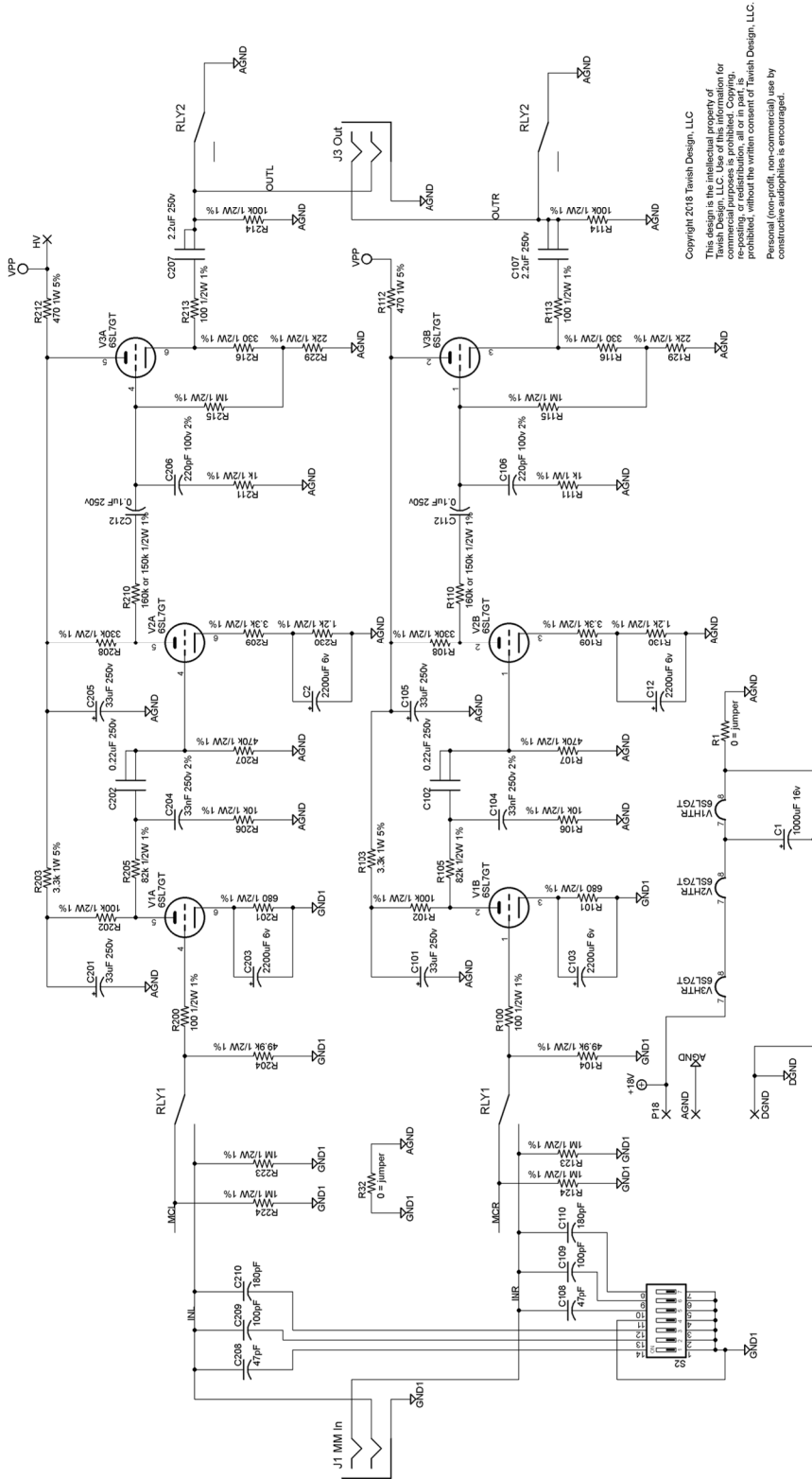
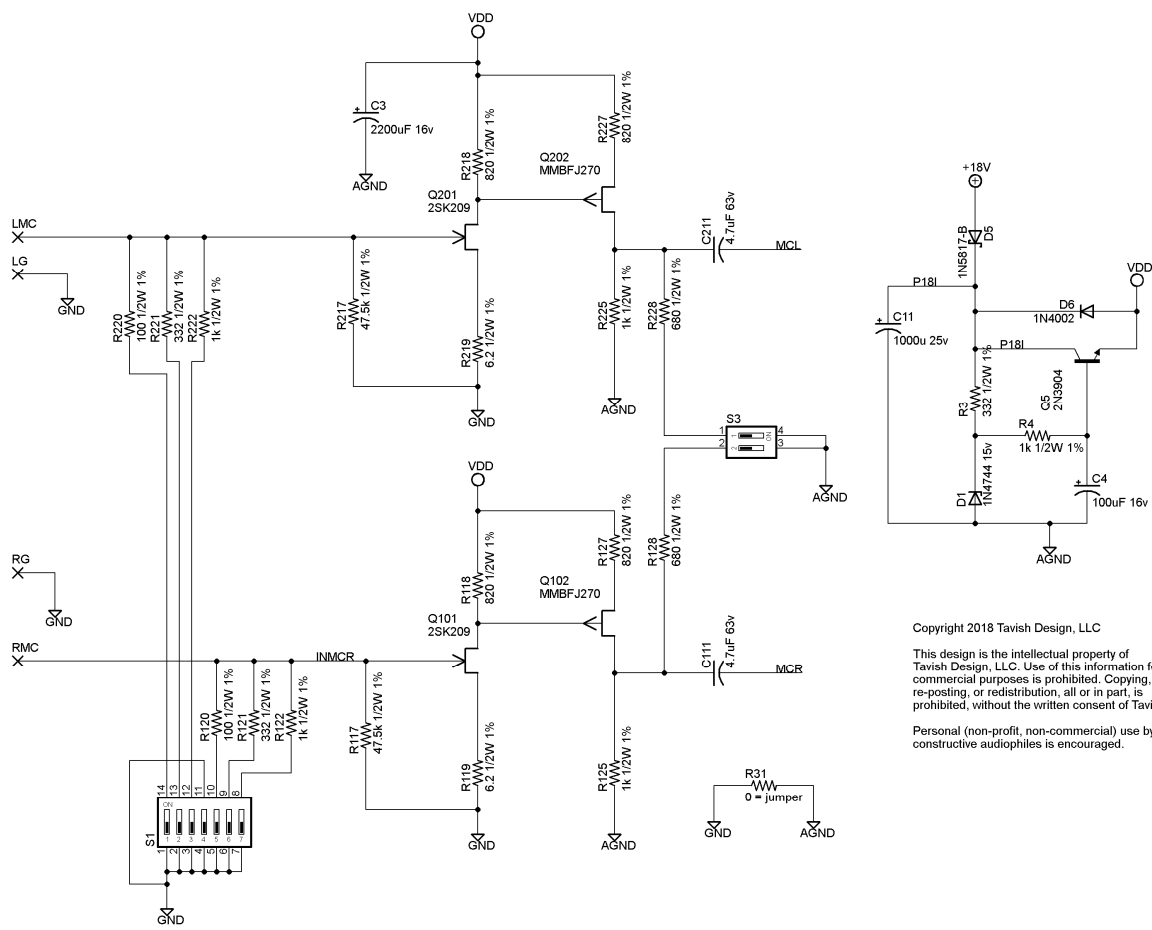

Fig. 5.2: Typical measured distortion over frequency, 560 mV RMS output level into 22 kΩ. ST = Sovtek 6H9C/6SL7GT, TS = Tung Sol Reissue 6SL7GT



Copyright 2018 Twitch Design, LLC
 This design is the intellectual property of Twitch Design, LLC. Use of this information for re-posting, or redistribution, all or in part, is prohibited, without the written consent of Twitch Design, LLC. Personal (non-profit, non-commercial) use by constructive audiophiles is encouraged.

Fig. 5.3: Schematic, sheet 1 of 4



Copyright 2018 Tavish Design, LLC
 This design is the intellectual property of Tavish Design, LLC. Use of this information for commercial purposes is prohibited. Copying, re-posting, or redistribution, all or in part, is prohibited, without the written consent of Tavish Design, LLC.
 Personal (non-profit, non-commercial) use by constructive audiophiles is encouraged.

Fig. 5.4: Schematic, sheet 2 of 4

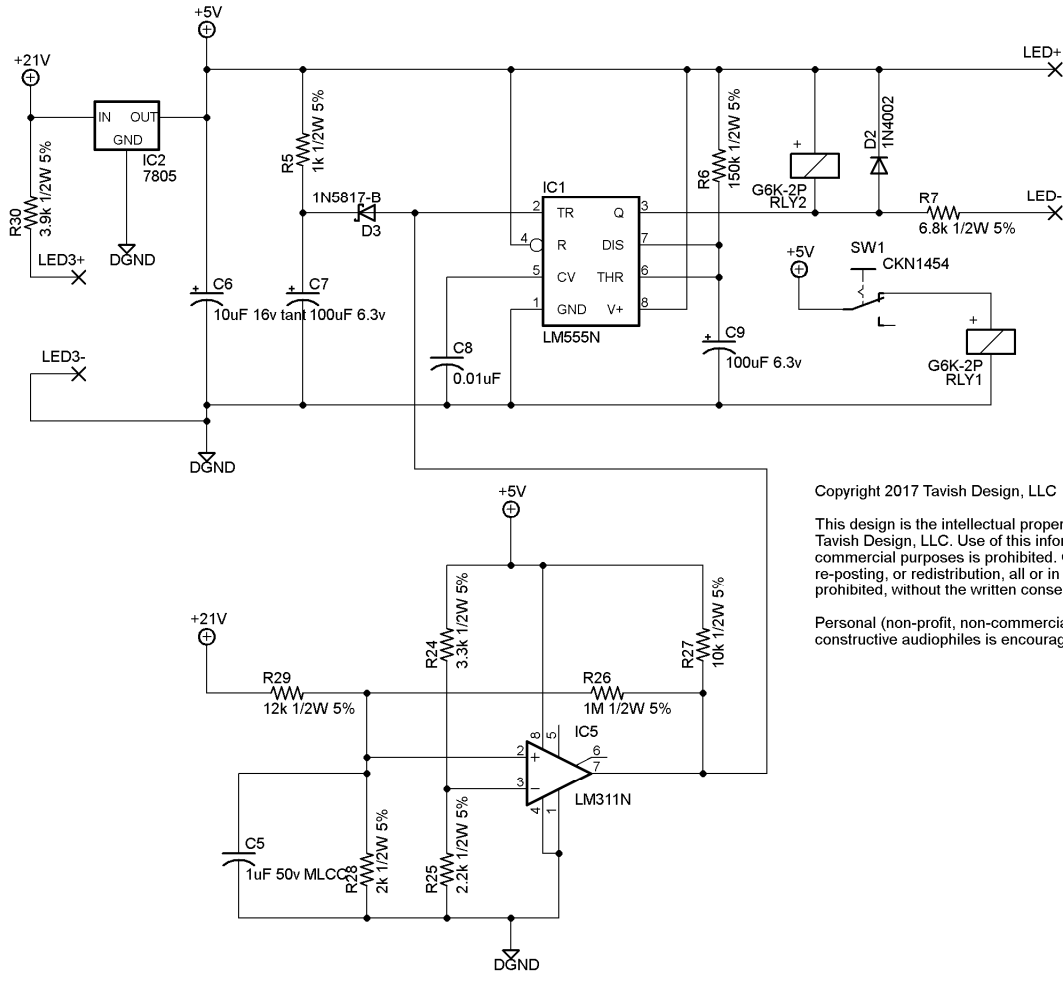

Copyright 2017 Tavish Design, LLC

This design is the intellectual property of Tavish Design, LLC. Use of this information for commercial purposes is prohibited. Copying, re-posting, or redistribution, all or in part, is prohibited, without the written consent of Tavish Design, LLC.

Personal (non-profit, non-commercial) use by constructive audiophiles is encouraged.

Fig. 5.5: Schematic, sheet 3 of 4

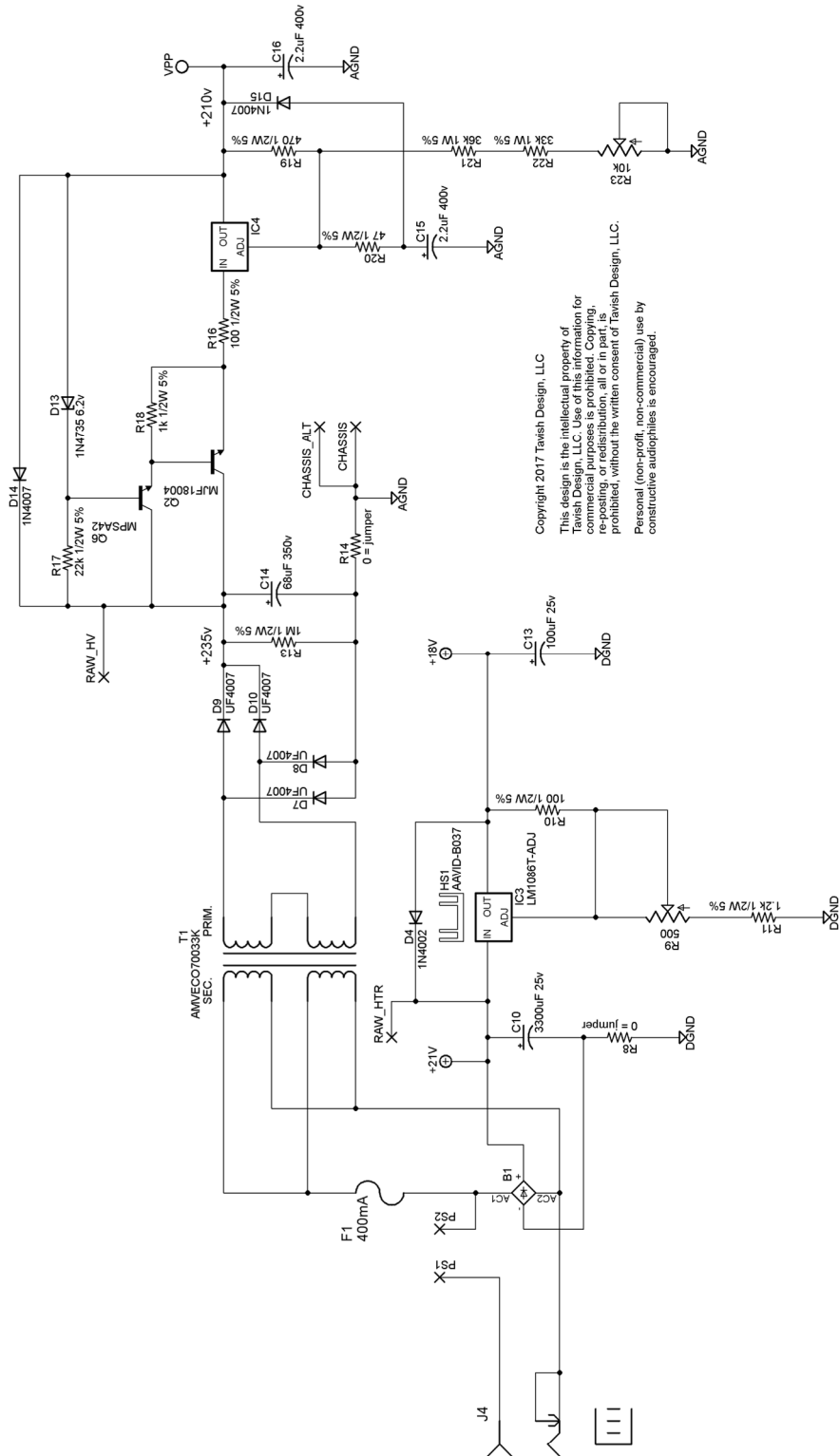

Copyright 2017 Tavish Design, LLC
 This design is the intellectual property of
 Tavish Design, LLC. Use of this information for
 commercial purposes is prohibited. Copying,
 re-posting, or redistribution, all or in part, is
 prohibited, without the written consent of Tavish Design, LLC.
 Personal (non-profit, non-commercial) use by
 constructive audiophiles is encouraged.

Fig. 5.6: Schematic, sheet 4 of 4

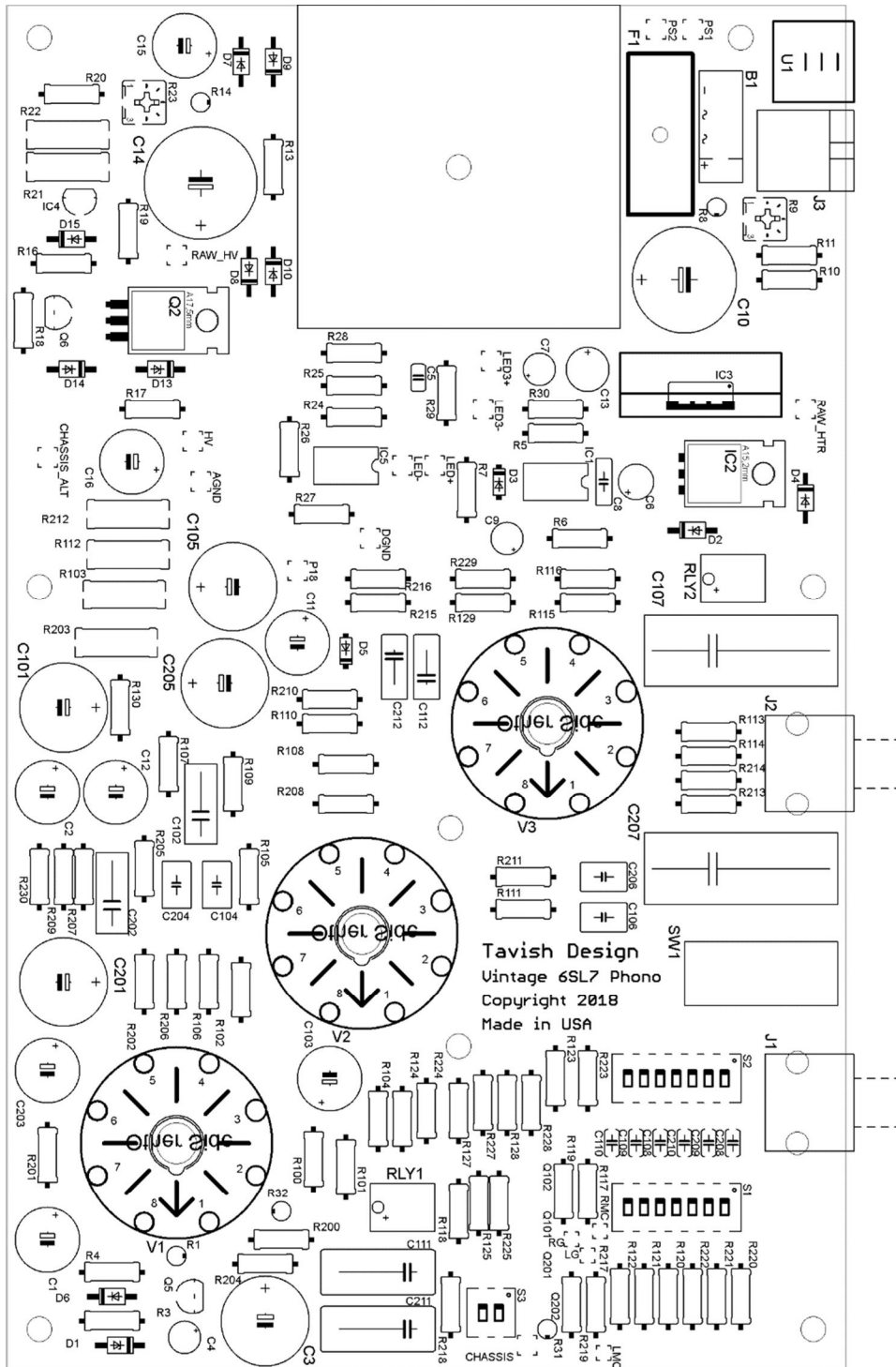

Fig. 5.7: Circuit board component placement.

Qty	Part Number(s)	Value	Description	Vendor	Manufacturer or Vendor Part No.
1	C1	1000uF 16v	electrolytic 5mm LS	Digikey	493-1790-ND
4	C2, C12, C103, C203	2200uF 6.3v	audio grade electrolytic 5mm LS	Mouser	647-UKA0J222MPD
1	C3	2200uF 16v	audio grade electrolytic 5mm LS	Mouser	647-UKA1C222MHD
1	C4	100uF 16v	electrolytic 2mm LS	Mouser	667-ECA-1CM101
1	C5	1uF 25v	MLCC	Digikey	399-9714-ND
4	C6, C7, C9	100uF 6.3v	electrolytic 2mm LS	Digikey	P5111-ND
1	C8	0.01uF	film capacitor 5mm LS	Mouser	667-ECQ-V1103JM
1	C10	3300uF 25v	electrolytic 7.5mm LS	Mouser	667-EEU-FR1E332
1	C11	1000uF 25v	electrolytic 5mm LS	Mouser	647-UVR1E102MPD
1	C13	100uF 25v	electrolytic 2.5mm LS	Mouser	667-ECA-1EHG101
1	C14	68uF 350v	electrolytic 7.5mm LS	Mouser	647-UCS2V680MHD
2	C15, C16	2.2uF 400v	electrolytic 5mm LS	Mouser	647-UVR2G2R2MPD
4	C101, C105, C201, C205	33uF 250v	electrolytic 5mm LS	Mouser	667-EEU-ED2E330
2	C102, C202	0.22uF 250v	film capacitor 10mm LS	Mouser	667-ECQ-E2224KF
2	C104, C204	33nF 250v 2%	film capacitor 5mm LS	Mouser	80-R79IC2330SH45G
2	C106, C206	220pF 100v 2.5%	film capacitor 5mm LS	Mouser	505-FKP2220/100/2.5
2	C107, C207	2.2uF 250v	WIMA film capacitor 22.5mm LS	Mouser	505-MKS42.2/250/10
2	C108, C208	47pF 5%	MLCC 5mm LS	Mouser	810-FK28C0G1H470J
2	C109, C209	100pF 5%	MLCC 5mm LS	Mouser	810-FK28C0G1H101J
2	C110, C210	180pF 5%	MLCC 5mm LS	Mouser	810-FK28C0G2E181J
2	C111, C211	4.7uF 63v	WIMA film capacitor 15mm LS	Mouser	505-MKS44.7/63/20
2	C112, C212	0.1uF 250v	Film capacitor 7.5mm LS	Mouser	667-ECQ-E2104KF

Table 5.2: Parts list, capacitors

Qty	Part Number(s)	Value	Description	Vendor	Manufacturer or Vendor Part No.
1	B1	2A 100v	bridge rectifier	Mouser	621-KBP201G
1	D1	1N4744 15v	1W Zener diode		
4	D2, D4, D6	1N4002	1A 100v rectifier diode		
1	D3	1N5817	1A 20v Schottky		
1	D5	1N5817	1A 20v Schottky		
4	D7, D8, D9, D10	UF4007	1A 1000v fast rectifier		
1	D13	1N4735 6.2v	1W Zener diode		
2	D14, D15	1N4007	1A 1000v rectifier diode		
1	HS1	AAVID-B037	TO-220 heatsink	Mouser	532-574502B03700G
1	IC1	LM555N	IC Timer 8-pin DIP		
1	IC2	7805	5v fixed TO-220 regulator		
1	IC3	LM1086IT-ADJ	Adj. TO-220 regulator	Mouser	926-LM1086ITADJNOPB
1	IC4	LM317LZ	Adj. TO-92 regulator		
1	IC5	LM311N	IC Comparator 8-pin DIP		
2	ICS1, ICS2	IC socket	3M 8-pin DIP socket	Mouser	517-4808-3004-CP
	LED2		No longer used		
	LED3		No longer used		
1	Q2	MJF18004	NPN high voltage transistor TO-220P	Mouser	863-MJF18004G
1	Q5	2N3904	NPN TO-92 transistor		
1	Q6	MPSA42	NPN high voltage transistor TO-92		
2	Q101, Q201	2SK209	Toshiba low noise audio JFET SC-59, GR-grade	Mouser	757-2SK209GRTE85LF
2	Q102, Q202	MMBFJ270	Fairchild p-channel JFET	Digikey	MMBFJ270CT-ND

Table 5.3: Parts list (including diodes, transistors, IC sockets, and heatsink)

Qty	Part Number(s)	Value	Description	Vendor	Vendor Part No.
	R1, R8, R14, R31, R32	0 = jumper	jumper		
5	R3, R116, R121, R216, R221	330 1/2W 1% (or 332)	metal film	Mouser	273-330-RC
7	R4, R111, R122, R125, R211, R222, R225	1k 1/2W 1%	metal film	Mouser	273-1K-RC
2	R5, R18	1k 1/2W 5%	carbon film		
1	R6	150k 1/2W 5%	carbon film		
1	R7	6.8k 1/2W 5%	carbon film (use 4.7k for diffused blue LED)		
1	R9	500 ohm trimmer	Bourns single turn cermet trimmer	Digikey	3362P-501LF-ND
2	R10, R16	100 1/2W 5%	carbon film		
1	R11	1.2k 1/2W 5%	carbon film		
2	R13, R26	1M 1/2W 5%	carbon film		
1	R15	No longer used			
1	R17	22k 1/2W 5%	carbon film		
1	R19	470 1/2W 5%	carbon film		
1	R20	47 1/2W 5%	carbon film		
1	R21	36k 1W 5%	metal oxide	Digikey	36KW-1-ND
1	R22	33k 1W 5%	metal oxide	Digikey	33KW-1-ND
1	R23	10k ohm trimmer	Bourns single turn cermet trimmer	Digikey	3362P-103LF-ND
1	R24	3.3k 1/2W 5%	carbon film		
1	R25	2.2k 1/2W 5%	carbon film		
1	R27	10k 1/2W 5%	carbon film		
1	R28	2k 1/2W 5%	carbon film		
1	R29	12k 1/2W 5%	carbon film		
1	R30	3.9k 1/2W 5%	carbon film		
6	R100, R113, R120, R200, R213, R220	100 1/2W 1%	metal film	Mouser	273-100-RC
4	R101, R128, R201, R228	680 1/2W 1%	metal film	Mouser	273-680-RC
4	R102, R114, R202, R214	100k 1/2W 1%	metal film	Mouser	273-100K-RC

2	R103, R203	3.3k 1W 5%	metal oxide	Digikey	3.3KW-1-ND
2	R104, R204	49.9k 1/2W 1%	metal film	Mouser	273-49.9K-RC
2	R105, R205	82k 1/2W 1%	metal film	Mouser	273-82K-RC
2	R106, R206	10k 1/2W 1%	metal film	Mouser	273-10K-RC
2	R107, R207	470k 1/2W 1%	metal film	Mouser	273-470K-RC
2	R108, R208	330k 1/2W 1%	metal film	Mouser	273-330K-RC
2	R109, R209	3.3k, 1/2W 1%	metal film	Mouser	273-3.3K-RC
2	R110, R210	160k 1/2W 1% for TungSol or JJ 6SL7GT (150k better for Sovtek 6H9C)	metal film	Mouser	273-160K-RC
2	R112, R212	470 1W 5%	metal oxide	Digikey	470W-1-ND
2	R117, R217	47.5k 1/2W 1%	metal film	Mouser	273-47.5K-RC
2	R118, R218	820 1/2W 1%	metal film	Mouser	273-820-RC
2	R119, R219	6.2 1/2W 1%	metal film	Mouser	603-MFR50SFTE52-6R2
6	R115, R123, R124, R215, R223, R224	1M 1/2W 1%	metal film	Mouser	273-1M-RC
	R126, R226		Not used, provision only		
2	R127, R227	820 1/2W 1% (or 825)	metal film	Mouser	273-820-RC
2	R129, R229	22k, 1/2W 1% (or 22.1k)	metal film	Mouser	273-22K-RC
2	R130, R230	1.2k 1/2W 1% (or 1.21k)	metal film	Mouser	273-1.2K-RC

Table 5.4: Parts list, resistors

Qty	Part Number(s)	Value	Description	Vendor	Vendor Part No.
2	RLY1, RLY2	G6K-2P-DC5	Omron low-signal relay	Mouser	653-G6K-2P-DC5
2	S1, S2	7 position DIP switch	C&K DIP switch, gold plated contacts	Mouser	611-SDA07H1BD
1	S3	2 position DIP switch	C&K DIP switch, gold plated contacts	Mouser	611-SDA02H1BD
1	SW1	7101SY9AV2BE	C&K vertical right-angle toggle SW	Digikey	CKN1454-ND
1	T1	AMVECO70033K	Talema 70033K 7VA PC mount toroidal transformer dual 15v secondaries (CAUTION on substituting for this part. See Sec. 7)	Digikey	1295-1047-ND
2	J1, J2	PJRAS1X2	Switchcraft dual phono jack	Mouser	502-PJRAS1X2S01AUX
1	FH1	LITTLEFUSE649	5x20mm fuseholder	Digikey	WK0011-ND
1	F1	400mA fuse	Littlefuse 0217.400HXP	Digikey	F2388-ND
1	J4	PJ-102A	2.1mm power jack (CUI)	Digikey	CP-102A-ND
1	U1	KEYSTONE7779	snap in screw terminal	Mouser	534-7779
3			PCB test points (black, yellow, red)		
3	TS1, TS2, TS3	8 pin octal tube socket	ceramic, gold plated contacts	Antique Electronic Supply	P-ST8-193G
3	V1 – V3	6SL7GT	vacuum tube, Sovtek 6H9C/6SL7GT	Antique Electronic Supply	T-6SL7GT-SOVT

Table 5.5: Parts list (including relays, switches, sockets, connectors, transformer, vacuum tubes, and other miscellaneous PCB mounted components)

Qty	Description	Vendor	Manufacturer or Vendor Part No.
1	Dialight green hi-efficiency 3mm panel mount LED	Mouser	645-558-0501-023F
1	Dialight blue hi-efficiency 3mm panel mount LED	Mouser	645-558-6003-027F
1	rocker switch (R13-73A2-B-02-R)	Jameco	316111
2	Quick connect terminals, 0.187"	Digikey	A27804-ND
8	1/4" nylon hex standoff #6-32		
8	nylon hex nut #6-32		
8	1/4" nylon screw #6-32		
2	3/8" #4-40 screw		
2	#4-40 nut		
2	#4-40 split washer		
2	#4-40 flat washer		
1	3/8" #6-32 pan head screw		
2	1/4" #6-32 pan head screw		
1	3/8" #6-32 black oxide pan head screw		
2	#3-24 plastite screw		
1	ground terminal 1/4-20		
4	#6-32 split washer		
1	#6 nylon flat washer		
1	ground post (Emerson 111-2223-001)	Mouser	530-111-2223-001
1	1/4-20 tooth washer		
1	18" 22ga. insulated stranded wire		
1	8" 24ga. insulated stranded wire (black)		
1	4" 24ga. insulated stranded wire (red)		
1	4" 24ga. insulated stranded wire (white)		
4	Self-adhesive rubber feet	Mouser	517-SJ-5012BK
1	Serial number sticker		
1	High voltage sticker		
1	Decorative flange		
1	Enclosure		
1	Wall transformer, 18VAC 1A	Jameco	ADU180100
1	Chassis mount RCA jack, red	AES	S-H267R
1	Chassis mount RCA jack, white	AES	S-H267W

Table 5.6: Parts list (including chassis mounted components, wall transformer, and hardware)

6 WARRANTY AND SERVICE

6.1 WARRANTY

With the exception of tubes, Tavish Design, LLC (hereinafter “Tavish Design”) warrants to the consumer this product to be free of defects in materials or workmanship for a period of six (6) years from the date of purchase (6 months on tubes). If you discover a defect, Tavish Design will (at its option) repair or replace the product at no cost to you (excluding return shipping and handling outside the 48 continental United States) provided that you send it prepaid to Tavish Design (see Section 6.2).

Proof of purchase in the form of a dated bill of sale which indicates that the product is within the warranty period may be required to obtain warranty service, if the date of sale is not in our records.

In the case of units purchased as a kit, the warranty only covers the components supplied and does not cover incorrect assembly or components damaged during assembly. Tavish Design cannot warrant your assembly of the product.

This warranty does not cover cosmetic damage or any damage that results from product misuse, product abuse, installation error, connection to an incorrect voltage supply, accident, improper maintenance, alterations, modifications not authorized in writing by Tavish Design, lightening, power surges, or acts of God. Use of parts not obtained from Tavish Design may void this warranty.

This warranty is limited to the replacement or repair of this product and not to damage to equipment of other manufacturers. Any applicable implied warranties, including warranty of merchantability, are limited in duration to a period of the express warranty as provided herein beginning with the original date of purchase and no warranties, whether express or implied shall apply to the product thereafter. Under no circumstances shall Tavish Design be liable for any loss, direct, indirect, incidental, special, or consequential damage arising out of or in connection with the use of this product.

This warranty does not cover the cost of parts and labor which would be otherwise provided without charge under this warranty, obtained from any source other than Tavish Design.

This warranty applies only to the consumer use of this product. The product is not warranted for use in public address, sound reinforcement, in any trade or business, or in an industrial or commercial application.

The warranty applies only to the original owner and is not transferrable.

This warranty is only valid in the United States of America. Units shipped outside the United States must be returned to Tavish Design for warranty service.

6.2 SERVICE

Please contact Tavish Design for service (in or out of warranty) if you believe your amplifier needs repair. Most technical issues can be resolved by email or phone. If your unit does require repair, we'll issue a return merchandise authorization (RMA) number, along with packing and shipping instructions and a street address for delivery.

For kits, Tavish Design offers a repair service in the event you are unable to get your kit working. Please contact us for more details.

Tavish Design, LLC

P.O. Box 129

Amawalk, New York 10501

info@tavishdesign.com

914-262-6988

7 DO-IT-YOURSELF GUIDANCE (FAQ)

This section is for the benefit of DIYers building the phono stage without the kit, and includes some guidance on parts substitutions, finding parts, and powering the board outside North America. It is based mostly on questions we've answered by email, and we'll update it as more questions arise.

1. Can I substitute for the Amveco / Talema 70033K PC-mounted toroid?

We don't recommend it. The Amveco / Talema 70033K works well as a step-up transformer and has very low radiated EM fields. Not all small PC-mounted transformers are as good. It seems to be readily available in UK and Germany, as well as from DigiKey.

<http://uk.rs-online.com/web/p/toroidal-transformers/2239216/>

<https://www.schukat.com>

2. I can't find a suitable 18VAC wall transformer in my country. What do I do?

Wall transformers don't seem to be as readily available outside the US & Canada. But you don't need a wall transformer to power the board; any source of 18 – 20 VAC 50/60 Hz will work. One

option is to use an external 18 VAC transformer in its own enclosure. One DIYer reported success with the Amveco / Talema 70061. Whatever you use, make sure it provides at least 18.0 VAC under 1A load; some nominal 18v transformers don't provide 18v under load.

If you do use a standard 18 VAC transformer instead of a wall transformer, resist the temptation to mount it in the same enclosure as the phono stage board. To bring the transformer and line voltage into the same enclosure as a MC phono preamp is inviting hum problems.

3. Can I use other tubes (such as the 6SN7GT) in the phono stage?

Unfortunately, no. The circuit is designed to work only with the 6SL7GT and no other tubes can be substituted.

4. Why are there cathode bypass capacitors in the first stage (C103/C203) and second stage (C2/C12)? Don't they affect the sound?

The use of cathode bypass capacitors is a tradeoff between noise, gain, and linearity. A stage with a bypassed cathode resistor will have lower noise and higher gain. Leaving the cathode resistor un-bypassed will decrease the gain and distortion, and it will increase the noise and the output impedance. So it is generally best to bypass the cathode resistor in the first stage of a low-noise amplifier and leave it un-bypassed in subsequent stages.

The operating point of the 2nd stage is carefully optimized with a partial cathode bypass to provide low distortion along with high gain, so that the Vintage Phono can have gain of 41dB and be used in a wide variety of systems. But C2 and C12 are optional for DIYers; omitting them will reduce the gain ~2dB and have minimal impact (< 0.5dB) on RIAA equalization accuracy.

And although we don't recommend it, you can also omit C103 and C203 if you prefer. Omitting them will reduce the gain ~2dB, increase the noise ~2dB, and have minimal impact (< 0.5dB) on RIAA equalization accuracy.

5. Can I build the Vintage Phono Stage without the MC preamp?

Yes, of course. Just omit all the components on schematic sheet 2, along with SW1 and RLY1. You'll have to jumper the normally-open contacts on the PCB relay RLY1 footprint, as shown in the figure below:

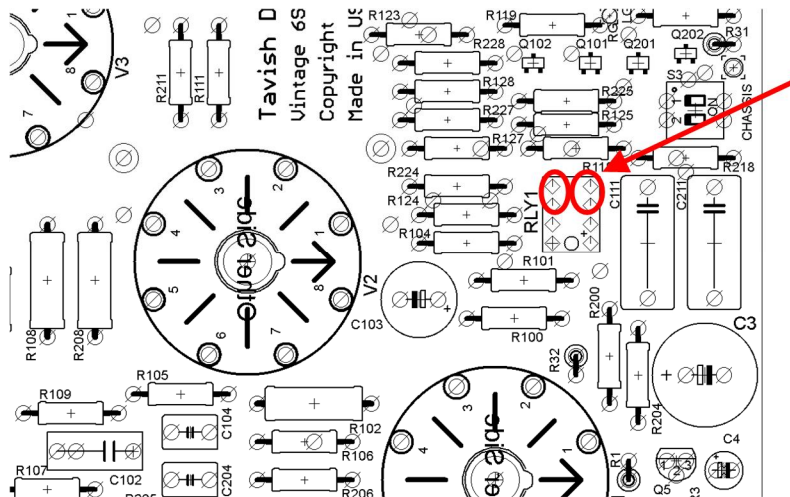

Omit RLY1
and jumper these 2
pairs of holes for MM
only operation. See text.

8 DESIGN CHANGES WITH RELEASE 2.2

1. New components D5 and C11 are added to prevent turn-off thump in MC mode.

Previous Design Changes with Release 2.1:

1. R110 and R210 become 160k Ω for Tung Sol and JJ 6SL7GT (but remain 150k Ω for Sovtek 6H9C).
2. R15 is deleted.
3. R29 changes from 15k Ω to 12k Ω .
4. C5 becomes 1uF MLCC.

Previous Design Changes with Release 2.0:

1. R118 and R218 change from 680 Ω to 820 Ω .
2. Q101 and Q201 change from the BL grade to the GR grade of 2SK209.
3. New capacitor C5, 0.1uF 50v MLCC
4. C11 and D5 are deleted.
5. Provision for on-board LED2 and LED3 removed.

9 COPYRIGHT, TRADEMARK, AND DISCLAIMERS

© Copyright Tavish Design, LLC 2018. All rights reserved. No part of this document may be reproduced by any means or translated to other languages without prior written consent of Tavish Design, LLC.

Tavish Design® is a registered trademark of Tavish Design, LLC.

Tavish Design is continuously improving its products and reserves the right to make changes to its products without incorporating those changes into previously sold units. The information provided here is subject to change without notice. Tavish Design, LLC is not responsible for errors contained herein or for consequential damages resulting from the use of this material.