

ASSEMBLY INSTRUCTIONS

NOTE: DON'T TIGHTEN BOLTS UNTIL ALL PARTS ARE CONNECTED. 2 PEOPLE ARE REQUIRED WHEN ASSEMBLING

PART NO	PART IMAGE	QTY	PART NO	PART IMAGE	QTY
A1		1	P		12
A2		1	Q		6
B1		1	R		5
B2		1	T		1
C1		1	U		1
C2		1			
D		1			
D1		1			
E		1			
N		3			
O		5			

①

②

③

④

⑤

MAXMIUM WEIGHT CAPACITY:120KG

ASSEMBLY INSTRUCTIONS

NOTE: DON'T TIGHTEN BOLTS UNTIL ALL PARTS ARE CONNECTED. 2 PEOPLE ARE REQUIRED WHEN ASSEMBLING

PART NO	PART IMAGE	QTY
F		2
G		2
H		2
I		2
J		4
P	M6*15MM	4
Q	M6*35MM	8
S		4
W		2
X		1
Y	M6	8

①

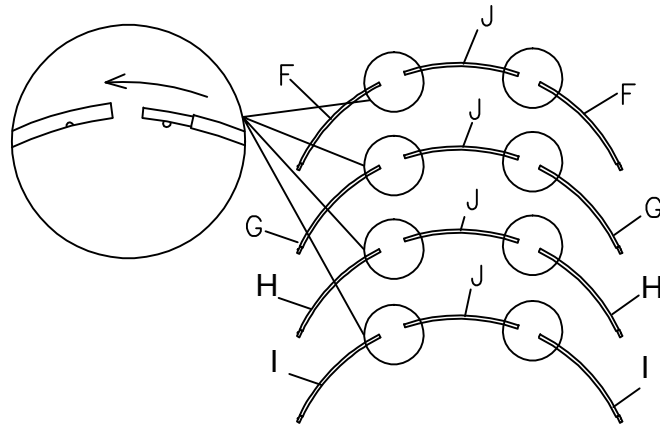

②

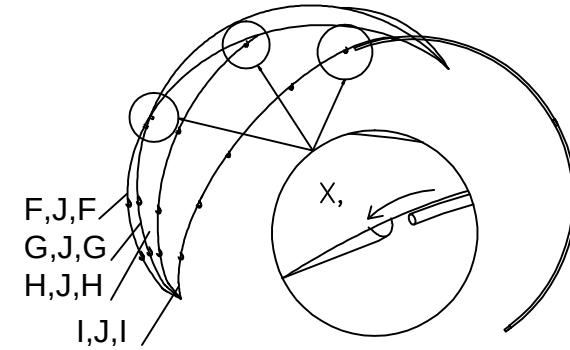

③

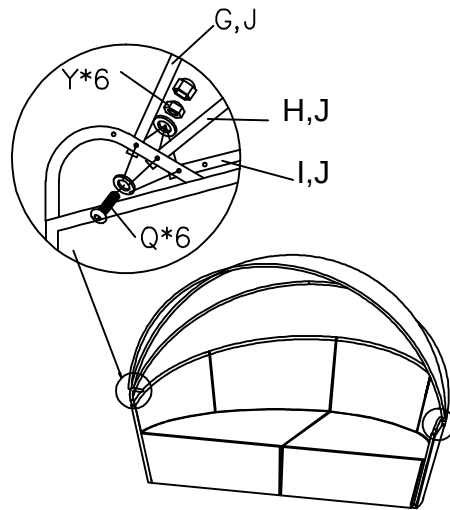

④

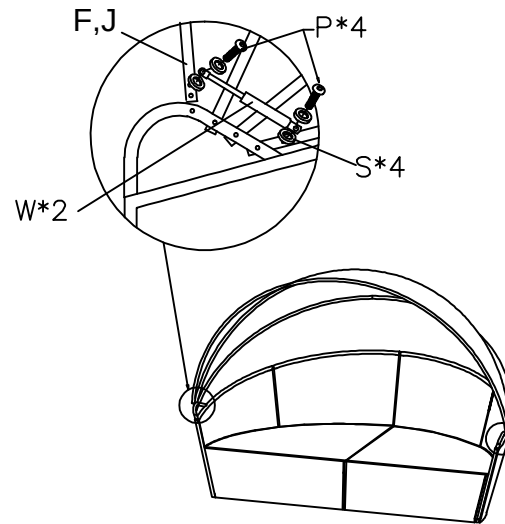

⑤

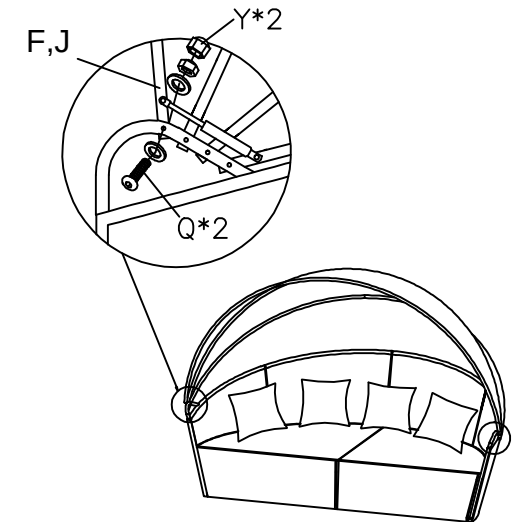

MAXMIUM WEIGHT CAPACITY:120KG

ASSEMBLY INSTRUCTIONS

NOTE: DON'T TIGHTEN BOLTS UNTIL ALL PARTS ARE CONNECTED. 2 PEOPLE ARE REQUIRED WHEN ASSEMBLING

PART NO	PART IMAGE	QTY
K		2
L		2
D		1
D1		1
M		4
O		4
Q		20
R		4

①

②

③

④

MAXMIUM WEIGHT CAPACITY:120KG