



EDMONTON KW - AIRPORT RD (E014)  
8202 42ND STREET  
LEDUC, Alberta T9E 8M6

NORTH WEST CRANE ENTERPRISES  
7015 SPARROW DR  
LEDUC, Alberta T9E 7L1  
Canada

Ken Jodoin  
Cell Phone: 780-293-5337  
Office Phone: 780-612-9855  
Email: kjodoin@edmkw.com

Eric Martin  
Cell Phone: (780)239-0766  
Email: ericm@nwce.ca

## Vehicle Summary

<b>Unit</b>		<b>Chassis</b>	
Model:	C500 Series Conventional.	Fr Axle Load (lbs):	36000
Type:	TRACTOR	Rr Axle Load (lbs):	69000
Description 1:	C550 42 Tandem Tri	G.C.W. (lbs):	160000
Description 2:			
<b>Application</b>		<b>Road Conditions:</b>	
Intended Serv.:	0093125 CRANE/CHERRY PICKER	Class A (Highway)	55
Commodity:	Heavy machinery.	Class B (Hwy/Mtn)	40
		Class C (Off-Hwy)	5
		Class D (Off-Road)	0
<b>Body</b>		<b>Maximum Grade:</b>	
Type:	Flatbed.		6
Length (ft):	20	Wheelbase (in):	311
Height (ft):	14	Overhang (in):	130
Max Laden Weight (lbs):	8000	Fr Axle to BOC (in):	38
		Cab to Axle (in):	273
		Cab to EOF (in):	403
		Overall Comb. Length (in):	1199
<b>Trailer</b>		<b>Special Req.</b>	
No. of Trailer Axles:	2	Canadian Registry	
Type:	Flatbed		
Length (ft):	65		
Height (ft):	13		
Kingpin Inset (in):	12		
Corner Radius (in):	0		
<b>Restrictions</b>			
Length (ft):	75		
Width (in):	102		
Height (ft):	13.5		

Approved by: \_\_\_\_\_

Date: \_\_\_\_\_

**Note: All sales are F.O.B. designated plant of manufacture.**



Std/ Opt	Description	\$ List	Weight
<b>Model</b>			
S	<b>C500 Series Conventional.</b> Threaded steel spring pins & bushings, 16mm. fasteners from rear cab support to end-of-frame, except tractor taper crossmember. Vinyl inside sunvisors, driver side includes strap & mirror, rider side includes strap; Under-dash center console w/ 2 cup holders, 2-12V outlets & a storage compartment, Glove box door with locking latch.	236,091	16,534
O	<b>C500: Conventional.</b>	0	0
O	<b>Chassis operation will not incl. stationary</b> application. Stationary operation is defined as running the engine under load while stationary at a substantial fraction of engine gross horsepower (60% or greater) for an extended period of time (longer than 5 - 10 minutes).	0	0
O	<b>Dealer/Customer declines engine w/CARB Idle</b> Emissions Reduction Feature.	0	0
O	<b>Non-Sleeper &amp; Dual Front Axle &amp; Tridem rear Axle.</b>	0	0
O	<b>State of Registry: Canada</b>	0	0
<b>Engine &amp; Equipment</b>			
O	<b>X15 565V 565@2000 1850@1000</b> 2021 with Intebrake, Productivity Series N09420 C333 0.....Reserve Speed Limit Offset ( N09380 C334 0.....Maximum Cycle Distance (C334 N09360 C400 474...Reserve Speed Function Reset N09200 C399 120...Standard Maximum Speed Limit N09400 C401 10...Maximum Active Distance (C40 N09220 C402 0.....Expiration Distance (C402) N09540 C395 1259..Expiration Distance (C395) N09260 C121 65....Maximum Accelerator Pedal Ve N09440 C234 YES...Engine Protection Shutdown ( N09460 C231 NO....Gear Down Protection (C231) N09580 C133 5.....Timer Setting (C133) N09680 C233 NO....Idle Shutdown Manual Overrul N09480 C132 1400..Max PTO Speed (C132) N09300 C128 65....Maximum Cruise Speed (C128) N09500 C239 NO....Cruise Control Auto Resume ( N09520 C238 NO....Auto Engine Brake in Cruise N09240 C209 120...Hard Maximum Speed Limit (C2 N09780 C190 80....High Ambient Temperature Thr N09740 C188 40....Low Ambient Temperature Thre N09760 C189 60....Intermediate Ambient Tempera N09720 C382 YES...Enable Hot Ambient Automatic N09600 C396 YES...Enable Impending Shutdown Wa N09620 C397 60....Timer For Impending Shutdown N09640 C206 35....Engine Load Threshold (C206) N09560 C225 YES...Enable Idle Shutdown Park Br	4,790	0
O	<b>EPA Emissions Warranty Engine</b>	0	0

Price Level: January 1, 2023

Deal: C550 42 Tandem Tri

Printed On: 11/24/2022 1:09:12 PM

Date: November 24, 2022

Quote Number: QUO-915669-F0T1M0

<i>Std/ Opt</i>	<i>Description</i>	<i>\$ List</i>	<i>Weight</i>
S	<b>PremierSpec</b>	0	0
O	<b>Powertrain Protect with SmartAccel - X15</b> Torque Rate Limiting	0	0
O	<b>Gearing Analysis: Performance</b> power before economy results.	0	0
O	<b>Customer's Typical Operating Spd: 65 mph.</b>	0	0
	<b>Effective VSL Setting 65.0 MPH or Greater (CAN)</b>	0	0
O	<b>Enable Most Fuel Efficient EIST</b>	0	0
S	<b>Engine Idle Shutdown Timer Enabled</b>	0	0
O	<b>Enable EIST Ambient Temp Overrule</b>	0	0
	<b>Eff EIST 1259000 Expiration Miles (CAN)</b>	0	0
S	<b>Air compressor: Cummins 18.7 CFM, Naturally</b> Aspirated for Cummins X15 engines	0	0
S	<b>Air Cleaner: Dual 13 in. ERA stainless steel cowl</b> mounted w/Kenworth bug w/Preferred Fit Element.	0	0
S	<b>Fan Hub: Horton 2-Speed for X15</b>	0	0
S	<b>Cooling module: 1780 square inches.</b> Includes aluminum radiator core, aluminum charge air cooler, translucent surge tank and washer bottle, silicone hoses, and extended life coolant. Drain valve is not available w/Allison transmissions.	0	0
O	<b>Radiator winterfront.</b>	170	2
O	<b>Bugscreen</b> Front of grille on 2.1M MD, C500 ,T800, T880, and W900. Behind grille on T680 and 1.9M MD.	279	2
O	<b>EXH: 2021 Twin Steer Single Vertical Independant</b> DPF/SCR with RH BOS tailpipe	8,335	0
S	<b>Tailpipe: 5 in. single 36 in. 45 degree curved.</b>	0	0
O	<b>Fuel Filter: Davco 382</b> Fuel/Water Separator	428	8
S	<b>Run Aid: Fuel Heat</b> *For Fuel Filter	0	0
O	<b>Start Aid: 12V Heat</b> *For Fuel Filter	82	1
O	<b>Immersion block heater 120V 1500W w/plug under</b> door on C500, T660, T800 & W900.	156	2
O	<b>Engine oil pan heater, 120V / 300W</b>	197	2

<i>Std/ Opt</i>	<i>Description</i>	<i>\$ List</i>	<i>Weight</i>
	Includes plug. For use with EPA 2007+ engines.		
O	<b>Block heater &amp; oil pan heater wired to separate plugs.</b>	0	0
S	<b>Alternator: PACCAR 160 amp, brush type</b>	0	0
O	<b>Batteries: 4 PACCAR GP31 threaded post (700-730) 2800-2920 CCA dual purpose.</b>	229	57
S	<b>Mitsubishi 105P55 12V Starter with Cummins and PX</b> PACCAR 12 volt electrical system. W/ centralized power distribution incorporating plug-in style relays. Circuit protection for serviceability, 12-volt light system w/circuit protection circuits number & color coded. Only for Cummins or PX engines.	0	0
O	<b>Battery disconnect switches 2, mounted on battery box.</b>	197	2
O	<b>Multi-function engine connector for body builder interface for Cummins.</b>	144	0
O	<b>Steel front engine supports.</b>	483	15
U	<b>Body Builder Control Harness coiled BOC/BOS</b>	94	0
<b>Transmission &amp; Clutch</b>			
O	<b>Transmission: Fuller RTLO18918B 18-speed</b> w/oil cooler & pump. Standard with synthetic lubricant. Includes severe-duty pilot bearing on all class 8 models. *Torque Limit: 1850 pound-feet.	4,483	121
O	<b>Aux: AT1202 2-speed electric over air shift</b> 3-position rocker switch dash mounted and includes synthetic lubricant	21,898	522
O	<b>Clutch: Eaton 15-1/2 in. Advantage Self-Adjust</b> to 2050 ft-lb, Ceramic, 6-Paddle	839	6
O	<b>Grease bank for clutch &amp; cross shaft.</b>	453	11
O	<b>Driveline: 4 Dana SPL250XL 2 centerbearing</b> for use w/auxiliary transmission or jackshaft, requires 3500057 interaxle driveline. Low maintenance offering from Spicer. On-highway 350K mi first service interval, 100K mi subsequent service interval on U-joint, splines lubed for life, quick disconnect end caps.	3,474	313
O	<b>High Capacity Input Shaft Bearing for High PTO</b> Duty Cycle	29	0
O	<b>Chassis will be fitted with LH transmission PTO.</b> (Prevents ECU From Interfering With PTO Only)	0	0
O	<b>Chassis will be fitted with RH transmission PTO.</b> (Prevents ECU From Interfering With PTO Only)	0	0
O	<b>14" Eaton High Capacity Standard Cooler</b> Oil to Water. For Transmission 1550-2250 LBFT, 18-speed AutoShift.	0	0
O	<b>Kenworth oil to water cooler for auxiliary transmission.</b>	355	0
O	<b>Aluminum clutch housing replacing cast iron for engines w/torque ratings 1450 to 2050 lb-ft.</b>	85	-52
O	<b>Two steel centerbearing crossmembers installed</b>	384	70

Std/ Opt	Description	\$ List	Weight
	with heavy-duty aluminum gussets replacing standard.		
<b>Front Axle &amp; Equipment</b>			
O	<b>Twin Steer Front Axle: 40,000 lbs. Dana Spicer D2200.</b>	11,200	1,546
O	<b>Twin Steer Front Axle Brakes: 40K Bendix ES S-cam 16-1/2x6 in.</b>	0	0
O	<b>Front dustshield: for drum brakes: all front axles.</b>	88	6
O	<b>Twin Steer Front Axle Brake Drums: 16-1/2x6 in. 40,000 lbs. cast.</b>	0	0
O	<b>Twin Steer front axle Hubs Iron hub pilot 40,000 lbs. 10 Bolt 11-1/4 in. bolt circle. Consider Wheelguards (5850002) with aluminum wheels</b>	-402	160
O	<b>ConMet PreSet Plus Hub package; front axle twin steer.</b>	0	0
O	<b>Twin Steer front axle vented hubcaps.</b>	0	0
O	<b>Twin Steer front axle automatic slack adjusters.</b>	0	0
U	<b>Twin Steer Front Axle Springs: slipper 40K</b>	41,977	712
U	<b>FR TORQUE RODS HVY DUTY RPL STD DUTY</b>	741	31
O	<b>Triple Power Steering Gears: 40K Sheppard XD120 Twin Steer axles only.</b>	7,858	402
O	<b>Power Steering Cooler:Radiator Mounted Air-to-Oil</b>	396	11
O	<b>Twin steer: standard axle setting.</b>	0	0
<b>Rear Axle &amp; Equipment</b>			
O	<b>Tridem Dana Spicer T69-172HP rear axle. Capacity varies. Wide track.</b>	23,917	2,580
O	<b>Rear Axle Ratio - 4.56.</b>	0	0
O	<b>Tridem Rear Brakes 16-1/2x7 in. to 78K; Bendix ES-extended service S-cam.</b>	0	0
O	<b>Tridem Rear Brake Drums: Cast.</b>	0	0
O	<b>Tridem Rear Hubs: Aluminum hub pilot 69K 11-1/4 in. bolt circle.</b>	0	0
O	<b>ConMet PreSet Plus Hub package; tridem rear axle</b>	0	0
O	<b>Tridem Rear axle automatic slack adjusters.</b>	0	0
O	<b>Spring Brake: 3030 long stroke Tridem 3 in. travel. Helps keep brakes in adjustment longer.</b>	0	0
O	<b>Dustshields for drum brakes: all rear axles.</b>	131	11

<i>Std/ Opt</i>	<i>Description</i>	<i>\$ List</i>	<i>Weight</i>
O	<b>Bendix 6S/6M anti-lock brake system.</b>	878	5
O	<b>Interaxle Driveline: 2 Dana SPL170XL only</b> available w/tridem axles.	1,138	94
O	<b>Wheel Differential Lock for Dana Spicer Axles</b> T69-170/172HP forward rear, center rear axle & rear rear axle.	4,209	167
O	<b>Flip valve, wiring and light separate for wheel</b> differential lock or driver controlled differential lock for forward rear, center rear & rear rear axles.	230	0
O	<b>Rear suspension: Tridem Neway ADZ378 78K.</b> 60 in. axle spacing. Air suspension w/10 in. ride height w/ dual leveling valves. Includes air suspension dump valve & cast brake spiders.	20,314	810
<b>Tires &amp; Wheels</b>			
O	<b>Front Tires: Michelin XZY3 445/65R22.5 20PR 4-4</b> F/8X4	4,443	476
O	<b>Rear Tires: Goodyear Armor Max Pro Grade MSD</b> 11R24.5 16PR	4,032	492
O	<b>Rear Tire Quantity: 12</b>	0	0
U	<b>FR WHL 4 ALCOA 83U65 22.5X13 AL 4-4,</b>	2,649	13
O	<b>Rear Wheel: Alcoa 98U63 24.5X8.25 AL</b> Ultra One High Polish Wheel.	2,994	-204
O	<b>Wheelguards: all axles.</b>	111	2
O	<b>Dual Front Axle: 4 wheels twin steer. Mirror</b> Polish outboard surface of aluminum wheels.	322	0
O	<b>Tridem Rear Axle: 6 Mirror Polish wheels.</b> outboard surface of outer dual or single aluminum wheels.	632	0
O	<b>Rear Wheel/Rim Quantity: 12</b>	0	0
<b>Frame &amp; Equipment</b>			
O	<b>Spliced Frame Rails: 11-5/8 x 3-7/8 x 3/8 in.</b> Steel 481 in. to 720 in. Truck frame weight is 3.80 lb.-in. per pair of rails. Section modulus is 21.43, RBM is 2,572,000 in-lbs per rail. Frame rail availability may be restricted based upon application, axle/suspension capacity, fifth wheel setting, or component/dimensional specifications. The results of the engineering review may result in a change to the requested frame rail. If a change is required Kenworth Application Engineering will advise the dealer of the appropriate material specification for a substitute rail.	3,573	1,277
O	<b>Warning: C500 twin steer wheelbase is measured</b> from C/L twin steer axle to bogie.	0	0
O	<b>Spliced Full Steel Insert: for 11-5/8 in. Steel</b> rail 481 in. to 720 in. Adds 2,132,000 in-lb to main rail RBM. 120K PSI. 11-5/8 in. primary insert RBM 4,704,000 in-lbs, section modulus is 39.20. Full frame insert length is equal to wheelbase plus rear frame	9,658	1,828

Std/ Opt	Description	\$ List	Weight
	cutoff plus dimension forward of front axle by model: T800, T880 = 21.26 in.; C500B = bumper setting minus 0.79 in.; W900B = 5.27 in., W900L = 1.50 in., W900S = 3.27 in.		
O	<b>Bumper: Straight steel, painted channel.</b> Requires a bumper setting code.	-84	50
O	<b>102 in. Bumper setting. Requires a bumper code.</b>	0	0
O	<b>Front tow hook: Center mounted, cast.</b> Requires iron front drive brackets.	442	11
S	<b>Steel shackle links.</b>	0	0
S	<b>Steel shackle brackets: Not req for T800 w/</b> front springs over 16,000 lbs.	0	0
S	<b>Front mudflaps.</b>	0	0
S	<b>Brackets: Steel front spring drive. Included on</b> W900 w/ front springs over 12000 lb. capacity, code not required.	0	0
O	<b>Steel underbell housing crossmember.</b>	85	22
O	<b>Custom Frame Layout: two chassis</b> CFL C/M: Locate Same As 952950 CFL F/T: LOCATE SAME AS 952950 CFL A/D: LOCATE SAME AS 952950 CFL DEF: LOCATE SAME AS 952950 CFL BBX: Locate The Same As 952950 CFL A/T: LOCATE THE SAME AS 952950 CFL AT: LOCATE SAME AS 952950	690	0
O	<b>Steel cantilever battery box: W/ aluminum diamond</b> plate cover, between twin steering axles.	727	0
O	<b>Battery box location: RH Side.</b>	118	15
O	<b>Steel forward intermediate crossmember: One with</b> heavy-duty aluminum gussets, replacing standard.	140	17
O	<b>Fifth Wheel: ILS&gt;40K air Hol FW35M924XL00 24 in.</b> slide, 9 in. height. Outboard mounting angles, 55K vertical rating, LH release. Air slide control valve standard in dash. Accommodates a 2 in. SAE kingpin. Requires some style of trailer connections.	3,180	570
O	<b>C-Channel or I-Beam is Supplied By Body Builder</b> and adds 1 to 999,999 lbs. RBM.	0	0
O	<b>Width across front tires exceeds 102 inches.</b> Dealer to review delivery constraints w/transporter.	0	0
O	<b>Potential vehicle over length due to use of</b> spliced rail. Dealer to review delivery options w/transporter.	0	0
O	<b>Width across rear tires exceeds 102 in. due</b> to combination of wide track rear axles & dual tires. Dealer to review delivery constraints w/transporter.	0	0
O	<b>Customer-installed bulkhead and/or headache</b> rack.	0	0
O	<b>Frame access package recommended. Dealer</b> contact declines.	0	0

<i>Std/ Opt</i>	<i>Description</i>	<i>\$ List</i>	<i>Weight</i>
	<b>FifthWheelRearFixedSetting</b> FW rear/ fixed setting behind bogie 18 in	0	0
S	<b>Rear mudflap arms: Betts B-25 standard-duty,</b> straight. Includes B1732 mounting brackets as standard.	0	0
S	<b>Rear mudflap shields: White plastic antisail w/</b> Kenworth logo.	0	0
S	<b>Square end-of-frame w/o crossmember; non-towing.</b>	0	0

### Fuel Tanks & Equip

O	<b>Fuel Tank: 120 US gallon 24.5in. aluminum BOC</b> replace. Class 8 fuel tanks w/ o locking caps include an anti-siphon device on the filler neck.	-26	6
O	<b>Fuel Tank: 120 US gallon 24.5in. aluminum BOC</b> add. Class 8 fuel tanks w/ o locking caps include an anti-siphon device on the filler neck. Multiple tank installations include a fuel equalization system w/ dual draw and return lines with a splitter valve located within 6 inches behind the cab. Single draw and return is an option in some cases.	2,517	119
O	<b>Large round DEF tank, 30 gallons.</b> The DEF tank will be located on the side you specified. If you have specific configuration or body builder concerns, please utilize the Custom Frame Layout option. Standard capacity is calculated by fuel capacity of the vehicle and will accommodate two diesel fill-ups for every DEF fill-up. For 1:1 DEF fuel fill ratio, add 7889204.	430	22
O	<b>Heavy-duty 7in. steel supports/straps for two</b> 24.5in. tanks. Two supports per tank.	880	36
O	<b>Polish only two aluminum tanks.</b>	874	0
O	<b>Polished cover for 1 DEF tank any size.</b>	359	3
O	<b>Polish only 7in. stainless steel straps for two</b> 24.5in. tanks; 2 straps per tank.	321	0
S	<b>DEF to fuel fill ratio 2:1 or greater.</b>	0	0
S	<b>Anti-siphon device in fuel tank filler neck.</b> For any number of fuel tanks.	0	0
S	<b>DEF tank location is LH.</b>	0	0
O	<b>Location: 120 gal fuel tank RH behind cab</b>	0	0
O	<b>Location: 120 gal fuel tank LH behind cab</b>	0	0

### Cab & Equipment

S	<b>Cab: Flat Glass Conventional Cab. Includes</b> aluminum & fiberglass fully hucked cab w/ all aluminum bulkhead doors & continuous stainless steel piano-style door hinge & pins. Includes heavy-duty reinforcements on the C500 as standard. Single electric horn is standard. Incandescent exterior lights include diagnosable bulb detection and warning. Trailer cable on tractors includes integrity	0	0
---	--	---	---



<i>Std/ Opt</i>	<i>Description</i>	<i>\$ List</i>	<i>Weight</i>
	detection. Standard features include multiplex wiring for interior lights, automated pre-trip inspection, short and open check diagnostics, and programmable daytime running lights. Warning alarm will sound when lights are left on.		
O	<b>Sleeper: 42 in. FlatTop modular sleeper.</b>	14,885	<b>513</b>
O	<b>Sleeper door, LH/RH w/ sliding window.</b>	846	<b>19</b>
O	<b>Hood: Sheetmetal Hood for use w/ 1780 radiator C500 Only.</b>	15,731	<b>500</b>
O	<b>Fenders: Two-piece aluminum diamond-plate fenders.</b>	4,400	<b>63</b>
S	<b>Flat steel grille w/ stainless steel frame</b> mounted to straight hood.	0	<b>0</b>
O	<b>Additional 4 ribs on radiator grille.</b>	126	<b>2</b>
O	<b>Heater/Air Conditioner: Separate Units, Cab &amp; Sleeper.</b> W/integral Defrosters & A/C. Separate Heater & A/C In Sleeper. Includes 5 Mode Rotary Control In Dash. 45,000 BTU Cab Heater. Separate 29,000 BTU Sleeper Heater W/AC, Thermostatically Controlled. T660 Includes Filter Media. Includes On/Off Button For Sleeper Unit In Air Flow Control Dial. Parallel Plumbing Is Included W/ All Sleepers And Allows For Independent Control Of Heat Output At Each Heater. Shutoff Valves Are Optional.	0	<b>0</b>
O	<b>Two ball valves for cab &amp; sleeper heaters.</b>	71	<b>4</b>
O	<b>Air Conditioning Excise Tax: Canadian Registry</b>	175	<b>0</b>
O	<b>Insulated water lines: For modular sleepers or auxiliary heaters.</b>	86	<b>2</b>
S	<b>Steering wheel: 18 in. 4-spoke.</b>	0	<b>0</b>
S	<b>Adjustable telescoping tilt steering column.</b>	488	<b>10</b>
O	<b>Off-highway dash switch: For ABS system. Includes indicator light.</b>	56	<b>0</b>
O	<b>Gauge: Air suspension pressure gauge.</b> For dual leveling valves, not dual read.	298	<b>0</b>
O	<b>Digital Clock With Alarm: Mounted In Sleeper</b>	52	<b>1</b>
O	<b>Gauge: Axle oil temperature gauge tri-drive axle.</b>	380	<b>0</b>
O	<b>Canadian instrument package: KPH speedometer</b> replaces MPH.	0	<b>0</b>
S	<b>KW Driver Information Center: Includes fuel economy, RPM display, trip information, truck information, diagnostics, gear display, alarm clock.</b>	0	<b>0</b>
S	<b>Instrument package: Includes speedometer, tachometer, fuel gauge, engine coolant temperature gauge, engine oil pressure, voltmeter.</b> Class 8 also includes primary & secondary air	0	<b>0</b>

<i>Std/ Opt</i>	<i>Description</i>	<i>\$ List</i>	<i>Weight</i>
	reservoir gauges & an air application gauge. DEF level gauge and warning lamp are included with 2010+ engines. Engine hour meter and outside air temperature readouts are standard. Primary read out will be MPH. Add 8240620 to switch primary scale to KPH in Canada.		
O	<b>Interior: Diamond Cab 42 in. Sleeper. Includes</b> diamond tufted upholstered side and back panels with accent lines, stitched upholstered diamond tufted door and carpeted kick panel, full diamond tufted vinyl headliner, button color matches primary lining color, wood grain dash panels, black rubber floormat. Includes Kenworth NavPlus HD navigation system on 2010 and later engines. Sleeper includes sleeper curtain, full diamond tufted vinyl headliner, diamond tufted upholstered door pads and wall panels with accent lines, button color matches primary lining.	3,062	73
O	<b>Interior color: Jet Black w/Dark Slate Gray.</b>	0	0
O	<b>Floormat in sleeper.</b>	0	0
O	<b>Driver Seat: Kenworth Air Cushion Premium Plus HB</b> leather. Heated. Standard features includes 7 in. fore and aft slide adjustment w/isolator, 6-58 degree recline, air suspension w/ cover, dual armrests, and triple chamber air lumbar support. Cushion and back include air adjustment. Seat cushion is 20 inches wide w/ 2-position tilt and 6-position front cushion support. Seat material has a horizontal stitch pattern and is 2-tone in color. Standard storage includes a side bolster pocket and a hanging pocket. Seat back is carpeted, and high back seats include a storage pocket. Seat is manufactured by National. Includes inside visor and retractable 3-point matching seat belts. Grey seat belts.	1,029	0
O	<b>Rider seat: Kenworth Air cushion Premium Plus HB</b> leather. Heated. Standard features includes 7 in. fore and aft slide adjustment w/isolator, 6-58 degree recline, air suspension w/ cover, dual armrests, and triple chamber air lumbar support. Cushion and back include air adjustment. Seat cushion is 20 inches wide w/ 2-position tilt and 6-position front cushion support. Seat material has a horizontal stitch pattern and is 2-tone in color. Seat back is carpeted, and high back seats include a storage pocket. Seat is manufactured by National. Includes inside visor and retractable 3-point matching seat belts. Grey seat belts.	1,591	19
O	<b>Seat color: All Jet Black.</b>	0	0
O	<b>Air line fitting: At driver seat.</b> Customer-installed air chuck.	50	4
O	<b>Dual KW driver seat armrests: Stowable inboard &amp; folding outboard.</b>	143	2
O	<b>Dual rider seat armrests: Stowable inboard &amp; folding outboard.</b>	159	2
O	<b>Premium pocket innerspring mattress on lower bunk.</b>	0	0
O	<b>Rubber floormat in tool compartment.</b>	0	0
O	<b>Speakers: Two 5-1/4 in. For sleeper w/fader in</b>	59	2

<i>Std/ Opt</i>	<i>Description</i>	<i>\$ List</i>	<i>Weight</i>
	radio for volume control to sleeper.		
O	<b>Solid post antenna: Mounted on LH cowl. Replaces</b> top-of-cab antenna. Recommended for dump trucks, loggers, & where overcab clearance is limited.	30	0
O	<b>Additional accessory power supply wiring.</b> In header.	20	0
O	<b>Speakers: Four 4 in. x 6 in. high performance.</b> Adds 2 speakers to the Panasonic standard 2. Located in cab header & rear cab corners.	137	0
O	<b>Logbook holder under dash.</b>	47	0
O	<b>Black dash: Replacing trim color dash.</b> W/Diamond trim the dash top, area by the glovebox & lower dash will be black. The trim around the main dash area, above the glove box, the header spear & trim on the doors will be woodgrain.	41	0
S	<b>Non-self cancelling turn signal: W/column-mounted</b> headlight dimmer switch & intermittent wiper control.	0	0
S	<b>Electric LH &amp; RH door locks.</b>	0	0
O	<b>Remote Keyless Entry</b>	426	0
S	<b>Kenworth TruckTech+</b> The Kenworth Remote Diagnostics system provides the Worlds Best reporting of engine and aftertreatment fault codes, as well as enhanced support for the truck owner through rapid communication of fault severity and recommended actions. This option is Standard on all Heavy Duty Kenworths with a PACCAR MX engine, Cummins X15 engine, PX engine or Natural Gas engine. Optional on Medium Duty Kenworths.	0	0
S	<b>Long grabhandle LH side of cab.</b>	0	0
S	<b>Grabhandle: LH inside door frame above dash.</b>	0	0
S	<b>Grabhandle: RH inside door frame above dash.</b>	0	0
O	<b>Grabhandle: LH inside door frame under dash</b> for twin steer.	71	0
O	<b>Grabhandle: RH inside door frame under dash</b> for twin steer.	74	0
O	<b>Grabhandle: RH w/ short extension over door.</b>	65	2
O	<b>Cab access package LH under cab for twin steer.</b>	614	130
S	<b>Daylite Door: LH/RH includes RH peeper window</b>	0	0
O	<b>Dual rectangular air horn 26 in. LH/RH top of</b> roof. Includes air horn covers.	157	4
S	<b>Look-Down, Pass. Door, Stainless 8.5x4.4</b>	0	0

<i>Std/ Opt</i>	<i>Description</i>	<i>\$ List</i>	<i>Weight</i>
O	<b>Dual convex heated mirror 8.5 inch w/ offset</b> mounting below regular mirror.	98	11
O	<b>Mirror: Dual 7 in. x 16 in. Moto HTD LTD.</b> LH and RH Motorized Aerodynamic. Switch Located On Door Pad.	603	2
O	<b>Mirror brackets 10 ft load width.</b>	316	24
O	<b>Electric-powered LH &amp; RH door window lifts.</b> Switch located on door.	294	0
S	<b>Two-piece roped-in windshield, w/ flat glass.</b>	0	0
O	<b>Exterior stainless steel sunvisor.</b>	522	11
O	<b>Second 4 1/2 in. rubber wheelwell fender</b> extension.	642	11
O	<b>4 1/2in. rubber wheelwell fender extension.</b>	306	11
O	<b>Link Cabmate suspension.</b>	751	22
O	<b>Quiet Cab Package: For Non-VIT Interiors.</b> Includes Firewall Insulation & Floor Covering w/ Sound Deadening Materials and Cowl Blanket	209	77
<b>Lights &amp; Instruments</b>			
O	<b>Headlamps: Dual Rectangular, extended life</b> halogen	61	0
O	<b>Marker Lights: Five, rectangular, LED</b>	202	0
O	<b>Turn Signal Lights: LED, mounted on fender.</b>	87	0
S	<b>LED Stop,Turn,Tail: With Two LED</b> Backup Lights and With An LED License Plate.	0	0
O	<b>Customer-installed road/fog lights switch &amp;</b> wiring.	40	0
O	<b>Dual Pedestal Floodlights: First Set</b>	305	2
O	<b>Floodlight Location: Located High Side of Sleeper</b> - First Set.	0	0
U	<b>Dual Low-Profile LED Amber Strobe Beacon centered</b>	1,145	15
O	<b>Daytime Running Lamps.</b>	180	0
S	<b>Marker Lights: Interrupter Switch.</b> Included in Turn Signal For All Models Except T3. The T3 Switch Is In The Dash.	0	0
S	<b>Omit Brake Light with Engine Brake.</b> Can only be selected when chassis also has engine brake. Cannot be used with options to delete engine brake.	0	0
O	<b>LH &amp; RH Courtesy Lamps: On upper skirt to light</b> up steps.	161	0

Std/ Opt	Description	\$ List	Weight
O	<b>Marker Lights: Midframe</b> & reflectors mounted standout. Required on tractors where overall length exceeds 30 feet.	217	22
O	<b>Electric Backup Alarm: Meets SAE J994 &amp; OSHA</b> requirements.	168	4
O	<b>Junction Box: Mounted Behind Cab or Sleeper</b> Not Mounted at End of Frame.	162	1
O	<b>Circuit Breakers: Replacing fuses. Does not</b> apply to any 5-amp fuse box position. Brakers include stop/brake/turn, tail lamp, high & low beams, marker/clearance lamps, horn, fuel heat, gauges, air dryer, HVAC controls, panel lamps. Some circuits will remain fuses.	45	0
<b>Air Equipment</b>			
O	<b>Air Dryer: Bendix AD-HF Extended Purge Heated</b> With Puraguard	156	0
S	<b>Moisture ejection valve w/ pull cable drain.</b>	0	0
O	<b>Full truck/tractor kit combined: Center frame</b> mounted. 7-way female receptacle and air connection gladhands are mounted BOC on center frame bracket & mounted at end-of-frame in taillamp bracket. Kit includes dash mounted trailer air supply valve, trailer hand control valve, and hoses/fittings for the valves. Dash mounted parking brake valve, tractor protection valve, and spring brake inversion/relay valve are standard.	1,104	15
O	<b>Air and light line length 12 feet</b>	0	0
O	<b>Straight air &amp; light lines: for semitrailer</b> application. Air lines detachable one end only; light line detachable both ends. Use w/ code 9110030. Note must code separately for straight air & light line lengths. Requires 12ft straight air & light.	250	8
O	<b>Power steering hydraulic pressure hose to -60</b> degree F.	4	0
U	<b>9140015 WIREBRAID AIR HOSE: FR</b>	1,259	60
O	<b>Locate air dryer inside RH rail BOC.</b> This code requires the use of a custom frame layout code.	0	0
O	<b>Air tanks: clear of transmission area.</b> This code requires the use of a custom frame layout code.	0	0
O	<b>Trailer ABS electric supply through SAE J560</b> 7-pin connector per TMC RP137).	0	0
<b>Extended Warranty</b>			
O	<b>Base Warranty - Severe Service</b> 12 months / 50,000 miles / 80,000 km.	0	0
S	<b>24 Month TruckTech+ Subscription for Cummins</b> Engines	0	0
O	<b>Base Warranty: Emissions</b> 5YR/100K MI - EPA Engine (Does not include CARB Clean Idle sticker)	0	0

<i>Std/ Opt</i>	<i>Description</i>	<i>\$ List</i>	<i>Weight</i>
<b>Miscellaneous</b>			
O	<b>GHG Secondary Manufacturer: Does Not Apply</b>	0	0
O	<b>Domestic severe service package.</b> Domestic severe service is required on any chassis operating within the 50 United States and Canada where the application includes class C road service 10% or more of the operation, or when vehicle will operate predominately on privately maintained, unimproved, or roughly prepared road surfaces. Specific vocations include, but are not limited to, oilfield service and Canadian logging service.	1,490	52
O	<b>Additional lead time required for off highway &amp; /or specialty component truck.</b>	0	0
U	<b>Stall built off highway specialty component</b>	0	0
O	<b>U.S. certification decals for Canadian trucks.</b>	0	0
<b>Promotions</b>			
<b>Paint</b>			
O	<b>Paint color number(s).</b>  N9702 A - L0225 WHITE N9770 BUMPER N0001 BLACK N9720 FRAME N0001 BLACK	0	0
O	<b>Steel Bumper Painted Frame Color</b>	0	0
O	<b>Sleeper Bulk Paint</b>	0	0
O	<b>Sleeper Standard Paint</b>	0	0
O	<b>1 - Color Paint - Sleeper</b> Color will be White if no other color is specified.	0	0
O	<b>Base coat/clear coat.</b> The Kenworth Color Selector contains additional instructions, as well as information on Kenworth paint guidelines and surface finish applications. Kenworth is standard with Dupont Imron Elite paint.	0	0

**Order Comments**

Total Weight

30,677

## Prices and Specifications Subject to Change Without Notice.

---

Unpublished options may require review/approval.

Dimensional and performance data for unpublished options may vary from that displayed in CRM.

---

### **PRICING DISCLAIMER**

*While we make every effort to maintain the web site to preserve pricing accuracy, prices are subject to change without notice. Although the information in this price list is presented in good faith and believed to be correct at the time of printing, we make no representations or warranties as to the completeness or accuracy of this information. We reserve the right to change, delete or otherwise modify the pricing information which is represented herein without any prior notice. We carefully check pricing specifications, but occasionally errors can occur, therefore we reserve the right to change such prices without notice. We disclaim all liability for any errors or omissions in the materials. In no event will we be responsible for any damages of any nature whatsoever from the reliance upon information from these materials. Please check your order prebills to confirm your pricing information*

## HORIZONTAL DIMENSIONS

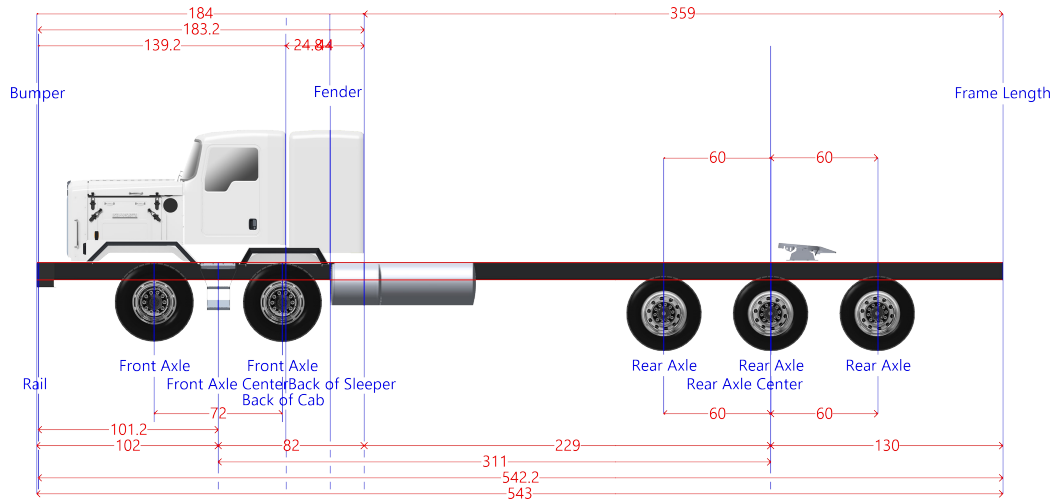

Dimension	Measurement	Start	End
Axle Spacing	120	251	371
Bumper to Back of Cab	184.0	-102	82
Bumper to Front Axle	102.0	-102	0
Bumper to Front Frame	0.8	-102	-101.2
Cab to End of Frame	403.0	38	441
Cab to Rear Axle	273.0	38	311
Effective Bumper to Back Of Cab	228.0	-102	126
Frame Length	542.2	-101.2	441
Front Axle to Back of Cab	38.0	0	38
Front of Frame to Axle	101.2	-101.2	0
Load Space	403.0	82	441
Overall Length	543.0	-102	441
Overhang	130.0	311	441
Pusher Offset #1	60.0	251	311
Pusher Offset #2	60.0	251	311
Pusher Offset #3	60.0	251	311
Tag Offset	60.0	311	371
Wheelbase	311	0	311



## VEHICLE WEIGHT RATING

### FRONT AXLE COMPONENTS

Component	Sales Code	Description	Ratings
<b>Axle</b>	2509144	Twin Steer Front Axle: 40,000 lbs. Dana Spicer	40,000
<b>Springs</b>	2849200	Twin Steer Front Axle springs: slipper 36K beam	36,000
<b>Power Steering</b>	2895043	Triple Power Steering Gears: 40K Sheppard XD120	40,000
<b>Hubs, Drums</b>	2702040	Twin Steer front axle Hubs Iron hub pilot	40,000
<b>Brakes</b>	2621405	Twin Steer Front Axle Brakes: 40K Bendix ES S-cam	40,000
<b>Tires</b>	4117185	Front Tires: Michelin XZY3 445/65R22.5 20PR 4-4	51,200
<b>Wheels</b>	5145190	Front Wheel: Alcoa 83462 22.5x13 twin steer,	51,200

Requested Front (Lbs): 36,000  
 Minimum: 8,000  
 Maximum: 36,000

The front axle weight rating cannot exceed 36000

### REAR AXLE COMPONENTS

Component	Sales Code	Description	Ratings
<b>Axle</b>	3151572	Tridem Dana Spicer T69-172HP rear axle.	69,000
<b>Hubs, Drums</b>	3407090	Tridem Rear Hubs: Aluminum hub pilot 69K	69,000
<b>Service Brakes</b>	3334305	Tridem Rear Brakes 16-1/2x7 in. to 78K; Bendix	78,000
<b>Spring Brakes</b>	3485301	Spring Brake: 3030 long stroke Tridem 3 in.	69,000
<b>Suspension</b>	3760038	Rear suspension: Tridem Neway ADZ378 78K.	78,000
<b>Tires</b>	4238002	Rear Tires: Goodyear Armor Max Pro Grade MSD	79,320
<b>Wheels</b>	5245275	Rear Wheel: Alcoa 98U63 24.5X8.25 AL	88,800

Requested Rear (Lbs): 69,000  
 Minimum: 16,000  
 Maximum: 69,000

The rear axle weight rating cannot exceed 69000

### GROSS COMBINATION WEIGHT RATING

<b>GCWR (lbs)</b>	160,000
<b>Min</b>	105,001
<b>Max</b>	999,000

**The Gross Combination Weight Rating cannot exceed 999000**

## WEIGHT DISTRIBUTION

Model: C500B

Actual performance of a specific unit can be affected by your operating conditions. The performance calculations should only be used as a guideline.



Recommended 5th wheel setting to achieve specified ground loads; measured from centerline of drive axles: 71 in. from the centerline of the drive axle(s).

Weight (lbs)	Front	Rear	Total
Chassis	17790	12887	30677
Tools/Driver	305	70	375
Fuel & DEF	1379	653	2032
Max Payload	16526	55390	71916
Auxiliary Payload	0	0	0
Total	36000	69000	105000
Specify Ground Load	<input type="text" value="36000"/>	<input type="text" value="69000"/>	<input type="text" value=""/>

### Auxiliary Payload

Item	Location from FA CL	Weight	Point Description
Load Point #1	<input type="text" value="0"/>	<input type="text" value="0"/>	
Load Point #2	<input type="text" value="0"/>	<input type="text" value="0"/>	
Load Point #3	<input type="text" value="0"/>	<input type="text" value="0"/>	
Component(s)	-	0	Composite Totals

Fifth wheel slide length is 24 inches  
 Selected rearmost setting is 18 inches  
 Wheelbase measurement: 311 inches  
 Overhang measurement: 130 inches

## FRAME LAYOUT

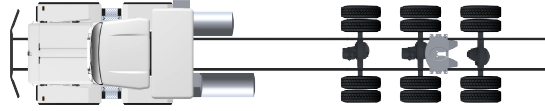

**Note:** Optional content may be displayed. The order has not yet received an engineering review. The actual arrangement of components may not be exactly as pictured. Additional changes may be made to the layout by Kenworth. Add a Custom Frame Layout code if an exact layout is required.

**Selected Options** (Wheelbase: 311)

Sales Code	Description	Length	Side
7214120	Fuel Tank: 120 US gallon 24.5in. aluminum BOC	60.5	Right
7216120	Fuel Tank: 120 US gallon 24.5in. aluminum BOC	60.5	Left
7722155	Large round DEF tank, 30 gallons.	20.1	Left
6404315	Steel cantilever battery box: W/ aluminum diamond	0.01	Right