

9265C
NEW AGE



RADIOCONTROL

9265C

Ferrari

A HYVA GROUP COMPANY

9265C



Extension Quick System and Smart Extension Sequence
Fast, precise, safe

Heavy duty hook attachment
Ruggedness and durability in all applications

Link on second boom
Boom negative angle allows access to confined spaces

Link on column
Constant lifting capacity on all main boom positions

Endless slewing
Efficient use in all the vehicle positions

Ergonomic control station and user-friendly interface
Comfortable, convenient and safe

Always stable
More than 40 stabilizer combinations available

Break the boundaries in performance and safety





7" color display
Simple and quick access to all the functions and information

Vertical stabilizer levers
Safe and fast. Excellent supervision of stabilizing operation

Ergonomic control station engineered for maximum operator comfort and ease of operation

Dynamic Load Diagram



Crane lifting capacity always under control in all stabilizer positions.
After the truck has been stabilized, the operator selects the load weight to be lifted. The display shows the permitted crane outreach based on the truck stability and load selected.

- Improved efficiency
- Easy to use
- Optimised safety

Magic Touch

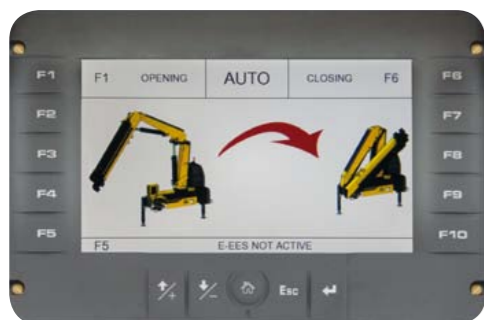

Crane Automatic folding/unfolding.
This system allows the operator to unfold the crane to a working position and fold the crane from any position to transport position by pressing a single button on the radio transmitter or display.

- Easy to start and close
- Save time
- Increased productivity and safety

High-tech development

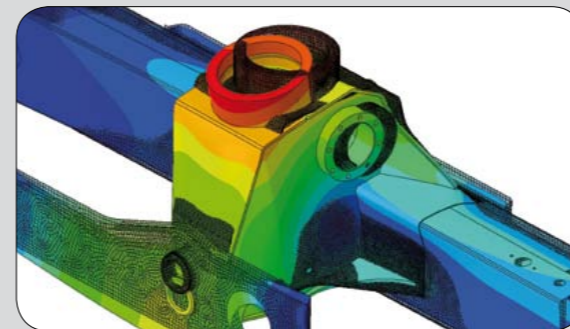

- Structures optimised for strength, weight and speed

Top Protection



- High value retention
- Top reliability

Endless performance

Continuous rotation and extreme flexibility
Endless slewing allows the crane to be operated without restrictions. The complete access to the working area, eliminates the need to reposition the truck, optimizing precision, productivity and safety.

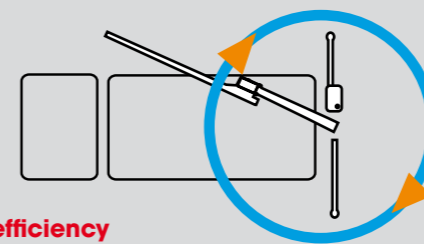

- Top efficiency
- Easy to use

Functional Aesthetic

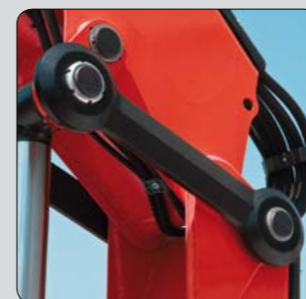

Forged double linkages on column and 2nd boom

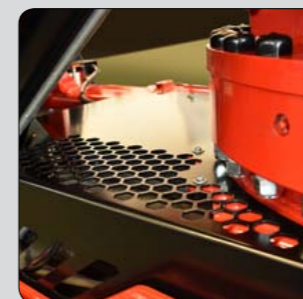

Hex Deck cover on base

Crane control system

F3XL

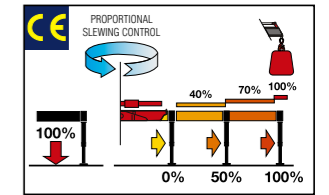

With a 3" TFT display and ergonomic keyboard, the crane operator can select optimum functional parameters. The system controls the stability with 2-step beam outreach monitoring and continuous slewing control.

F4XL+TOP

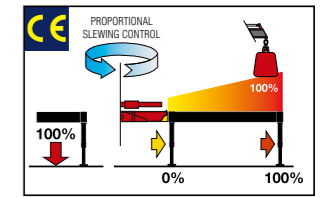

A 7" color display with integrated keyboard gives the operator a higher level of awareness of the crane operation and allows selection of the best parameters for effective use. The system detects the exact position of the beams and proportionally calculates the stability.

Wide range Radio selection



Hetronic Not CE



Hetronic CE Basic



Scanreco



Hetronic CE Graphic



Powered by Danfoss

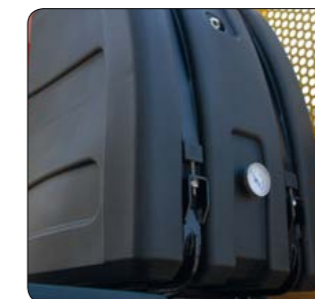

High volume oil tank made in sandwich-structured materials (PEX and PA6)



Robust column design and hoses cover

9265C Technical data

	Lifting Moment	Slewing Angle	Working pressure	Oil tank capacity	Max Oil flow	Max lifting height	Standard crane weight
	tm	°	bar	l	l/min	m	kg
A2	24,8	endless	345	130	80	10,40	2745
A3	24,3	endless	345	130	80	12,40	2885
A4	23,8	endless	345	130	80	14,50	3025
A5	23,3	endless	345	130	80	16,70	3150
A6	23,0	endless	345	130	80	19,00	3255
A7	22,6	endless	345	130	80	21,20	3375
A8	22,3	endless	345	130	80	23,50	3465
A4J3	12,9	endless	355	130	80	22,70	3685
A5J3	12,0	endless	355	130	80	24,20	3640
A6J2	12,6	endless	350	130	80	24,50	3530

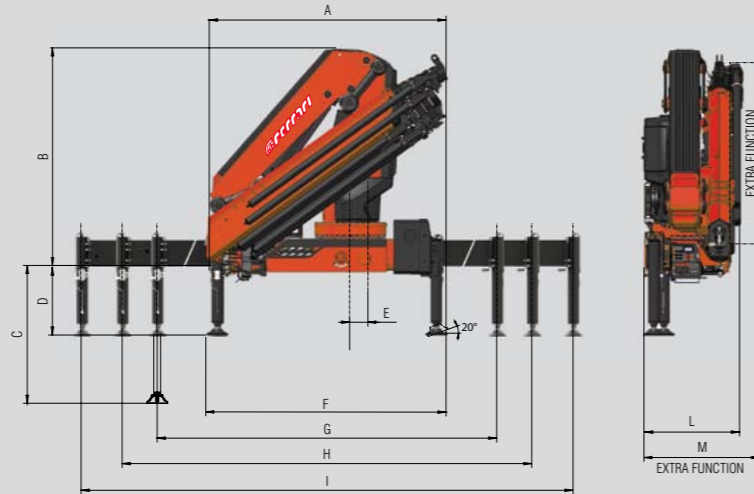

	A2	A3	A4	A5	A6	A7	A8	A4J3	A5J3	A6J2
A	2530	2530	2530	2530	2530	2530	2530	2575	2550	2540
B	2335	2335	2335	2335	2335	2335	2335	2700	2595	2580
C	1348	1348	1348	1348	1348	1348	1348	1348	1348	1348
D	666	666	666	666	666	666	666	666	666	666
E	250	250	250	250	250	250	250	250	250	250
F	2520	2520	2520	2520	2520	2520	2520	2520	2520	2520
G	4860	4860	4860	4860	4860	4860	4860	4860	4860	4860
H	5500	5500	5500	5500	5500	5500	5500	5500	5500	5500
I	7420	7420	7420	7420	7420	7420	7420	7420	7420	7420
L	980	980	980	980	980	1055	1055	1100	1100	1100
M	1100	1100	1100	1100	1100	1130	1130	-	-	-



A2	kg	5860	3995	3030																
	m	4,23	6,13	8,03																
A3	kg	5745	3880	2910	2310	1850	1505	1000												
	m	4,23	6,13	8,03	10,06	12,09	14,22	16,43												
A4	kg	5315	3695	2750	2155	1780	1435	1175	605											
	m	4,31	6,21	8,28	10,14	12,17	14,30	16,43	18,76											
A5	kg	5315	3540	2610	2015	1645	1385	1145	960	535										
	m	4,39	6,29	8,19	10,22	12,25	14,38	16,51	18,68	20,96										
A6	kg	5125	3390	2470	1885	1515	1260	1085	765	680										
	m	4,48	6,38	8,28	10,31	12,34	14,47	16,60	18,76	20,96										
A7	kg	4960	3265	2355	1775	1410	1150	980	855	725	630									
	m	4,56	6,46	8,36	10,39	12,42	14,55	16,68	18,85	21,05	23,15									
A8	kg	4805	3140	2250	1675	1315	1060	885	765	680	580									
	m	4,65	6,55	8,45	10,48	12,51	14,64	16,77	18,93	21,13	23,23									
A4J3	kg				855	745	660	595	510	435										
	m				15,03	16,73	18,48	20,23	22,03	23,96										
A5J3	kg				695	625	570	525	465	415										
	m				17,21	18,77	20,33	21,89	23,55	25,32										
A6J2	kg				650	600	560													
	m				19,33	20,71	22,19													

Standard

- Multifunctional radio remote control
- Sauer Danfoss PVG32
- P-PB Proportional Power Boost
- Flanged valves
- Designed in accordance with EN12999
- Design class: HC1-HD5
- Oil tank
- Manually extendable stabilizers
- Fixed stabilizer cylinders
- Swivel stabilizer foot
- Centralized greasing system
- EQS Extension Quick System
- SDV Smooth Descent Valve
- Red Power
- F3XL Crane control system (CE)

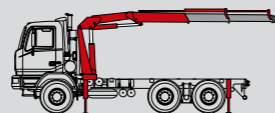

Recommended truck M.T.T. ton 18 - G.V.W. ton 18



One model, many applications



Waste handling



Construction



Fence posts, poles and landscaping



With winch



9265C
NEW AGE



Quality and environmental certified



F.lli FERRARI

Via Einstein, 8
42028 Poviglio (RE) Italy
Tel. +39 0522/486308
Fax +39 0522/486330
info@flliferrari.it
marketing@flliferrari.it
www.flliferrari.com

Dealer

Data, descriptions, and illustrations pertain only and uniquely to models sold at the time of printing of this brochure. After the date of printing this information is purely indicative and not binding upon F.lli Ferrari. Future modifications are solely at the discretion of F.lli Ferrari and are always in compliance with applicable and pertinent safety standards. To obtain updated data, descriptions, and illustrations, contact the manufacturer or your reseller. Cranes manufactured and/or marketed by F.lli Ferrari.