

7183C
NEW AGE



7183C

FERRARI

A HYVA GROUP COMPANY

7183C

Extension Quick System and Smart Extension Sequence
Fast, precise, safe

Forged hook attachment
Ruggedness and durability in all applications

Link on second boom
Efficiency in confined spaces thanks to negative angle

Link on column
Constant lifting capacity on all main boom positions

425° Slewing angle
The widest slewing angle for medium sized cranes

Always stable
More than 40 stabilizer combinations available

Break the boundaries in performance, safety and neatness



7" color display
Simple and quick access to all the functions and information

Vertical stabilizers levers
Safe and fast. Excellent supervision of stabilizing operation

Control station distinguished by operator comfort and user-friendly interface derived from dedicated ergonomic and user preference studies

Dynamic Load Diagram



Crane lifting capacity always under control in all stabilizer positions.
After the stabilization, operator can select the load to be lifted. Display shows the permitted crane outreach based on the stability and the load selected.

- Improve the efficiency loading/unloading cycle
- Easy to use and safety optimised

Magic Touch

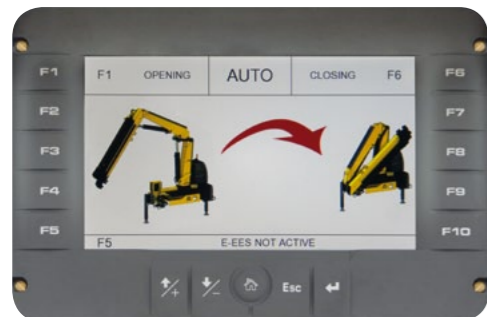

Crane Automatic folding/unfolding.
System allows driver to open the crane from fold position to working position and back to transporting position by the pressure of a single lever on radio transmitter (or a button on the display).

- Easy to start and close
- Save time, increase productivity and safety

High tech development

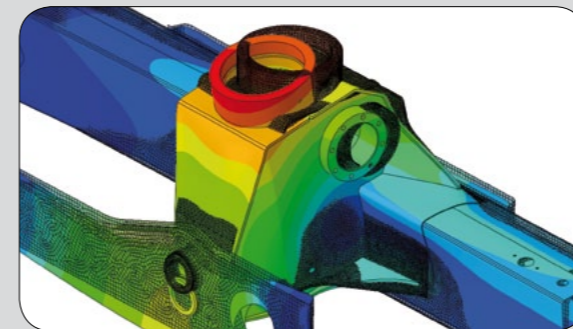

- Structures optimised for strength, weight and speed

Top Protection



- High value retention
- Top reliability

Slewing Angle

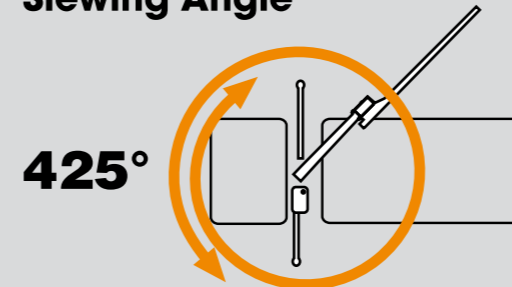

- The widest slewing angle for medium sized cranes
- Top efficiency and easy to use

Functional Aesthetic

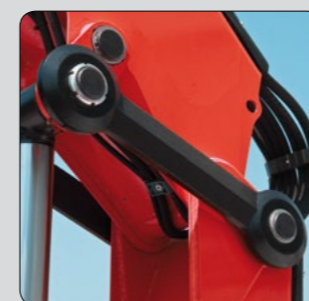

Forged double linkages on column and 2nd boom

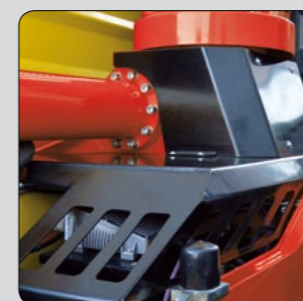

Hex Deck cover on base

Crane control system

F3XL

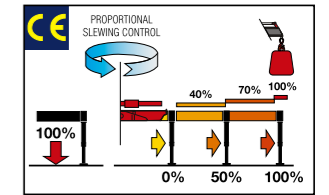

With a 3" TFT display and ergonomic keyboards, the operator can supervise the crane working and select the best parameters for effective use. The system controls the stability with 3-step beam outreach monitoring and continuous slewing control.

F4XL+TOP

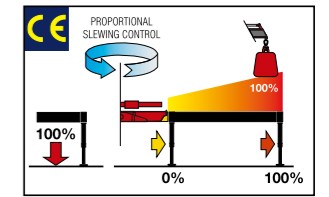

A 7" color display with integrated keyboard gives the operator a higher level of awareness of the crane operation and allows selection of the best parameters for effective use. The system detects the exact position of the beams and proportionally calculates the stability.

Wide range Radio selection (Standard)



Hetronic CE Basic



Scanreco



Hetronic CE Graphic



Powered by Danfoss

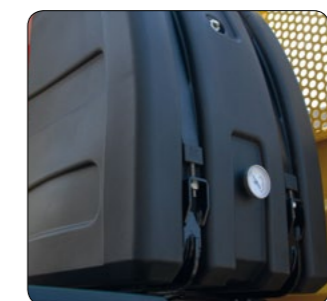

High volume oil tank made in sandwich-structured materials (PEX and PA6)



Robust column design and hoses cover

7183C *Technical data*

	Lift Moment	Slewing Angle	Working pressure	Oil tank capacity	Max Oil flow	Max lifting height	Standard crane weight
	tm	°	bar	l	l/m	m	kg
A2	17,3	425	330	130	60	12,2	1995
A3	16,8	425	330	130	60	14,4	2125
A4	16,4	425	330	130	60	16,5	2245
A5	16,0	425	330	130	60	18,8	2355
A6	15,6	425	330	130	60	21	2450

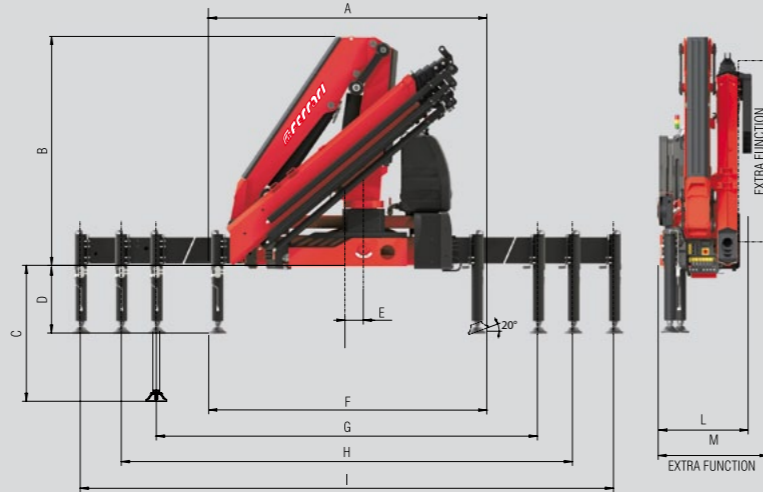

	A2	A3	A4	A5	A6
A	2450	2450	2450	2450	2450
B	2330	2330	2330	2330	2330
C	1362	1362	1362	1362	1362
D	670	670	670	670	670
E	160	160	160	160	160
F	2445	2445	2445	2445	2445
G	4200	4200	4200	4200	4200
H	5400	5400	5400	5400	5400
I	6600	6600	6600	6600	6600
L	817	817	817	890	890
M	960	960	960	1020	1020

Model	kg	m	kg	m	kg	m	kg	m	kg	m	kg	m
A2	3775	4,58	2575	6,53	1965	8,48	1460	10,86	1105	12,91	845	15,06
A3	3605	4,66	2435	6,61	1830	8,56	1460	10,61	1105	12,91	845	17,21
A4	3450	4,75	2305	6,7	1705	8,65	1340	10,7	1105	12,75	845	19,31
A5	3305	4,83	2185	6,78	1590	8,73	1230	10,78	995	12,83	845	19,31
A6	3175	4,91	2080	6,86	1490	8,81	1130	10,86	900	12,91	745	19,31

Standard

- Multifunctional radio remote control
- Sauer Danfoss PVG32
- Load limit device
- P-PB Proportional Power Boost
- Flanged valves
- Designed in accordance with EN12999
- Design class: HC1-HD5
- Oil tank
- Manually extendable stabilizers
- Internal stabilizers pipes
- Fixed stabilizer cylinders
- Swivel stabilizer foot
- Centralized greasing system
- EQS Extension Quick System
- SDV Smooth Descent Valve
- Red Power
- F3XL Crane control system (CE)

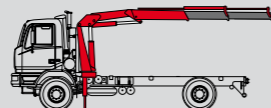

Recommended truck M.T.T. ton 15 - G.V.W. ton 15

With 5 tm fly Jib



One model, many applications

Brick handling application



Waste handling application



Construction application



Fence posts, poles and landscaping application



With winch



7183C

NEW AGE



Quality and environmental certified

FERRARI®

F.lli FERRARI CORPORATION S.p.A.

Via Einstein, 8
42028 Poviglio (RE) Italy
Tel. +39 0522/486308
Fax +39 0522/486330
info@flliferrari.it
marketing@flliferrari.it
www.flliferrari.com

Dealer



Data, descriptions, and illustrations pertain only and uniquely to models sold at the time of printing of this brochure. After the date of printing, this information is purely indicative and not binding upon F.lli Ferrari. Future modifications are solely at the discretion of F.lli Ferrari and are always in compliance with applicable and pertinent safety standards. To obtain updated data, descriptions, and illustrations, contact the manufacturer or your reseller. Cranes manufactured and/or marketed by F.lli Ferrari.