

## ZEPHYR LOW-HEADROOM TROLLEY HOISTS

### CAPACITIES

1-1/2 to 24 Tons

### LIFT

8 Feet Standard

### OPTIONS

Spark & Corrosion Resistance  
Clean Room

Chester Zephyr low-headroom trolley hoists, as the name implies, are designed for applications where head room is very limited, preventing the use of standard hoists. They are ideal for existing structures with low ceilings as well as new construction where low ceilings are required. These low-headroom hoists are equipped with concentrically machined, cast iron, precision bearing trolley wheels.

Each Zephyr low-headroom hoist is custom built to fit the beam size, flange width and curve radius for the specific application.

### KEY FEATURES

**CHESTER ZEPHYR LOW-HEADROOM TROLLEY HOISTS CONTAIN ALL OF THE SAME KEY FEATURES AS THE HOOK-SUSPENDED MODELS.**

**POSITIVE ENGAGEMENT RACK & PINION OR SPROCKET & ROLLER CHAIN TROLLEY DRIVES**

Available for use on inclined monorails or for shipboard use to provide increased control over the trolley to prevent unintended movement.



▲ RACK & PINION TROLLEY DRIVE

### SPECIFICATIONS

Capacity (short tons)	Catalog Number		Standard Lift (ft.)	Load Chain Length (2 Chains per Hoist)	Minimum Radius Curve ††	Minimum Distance from Bottom of I-Beam to Hook (in.)	Chain Pull to Lift Full Load (lbs.)	Chain Overhauled to Lift Load One Foot (ft.)	Weight (lbs.)	
	Plain Trolley	Geared Trolley							Net	Gross
1-1/2	1421 - 1-1/2	1422 - 1-1/2	8	9'-6"	6'-6"	6-1/4	41	87	207	230
2	1421 - 2	1422 - 2	8	9'-6"	6'-6"	6-1/4	54	87	210	233
3	1421 - 3	1422 - 3	8	18'-3"	6'-6"	7-3/8	42	176	305	335
4	1421 - 4	1422 - 4	8	18'-3"	7'-6"	8	56	176	308	340
5	1421 - 5	1422 - 5	8	10'	8'-6"	8-3/4	79	165	574	633
6	1421 - 6	1422 - 6	8	10'	8'-6"	8-3/4	94	165	574	633
8	1421 - 8	1422 - 8	8	19'	9'-6"	11	64	355	650	773
10	1421 - 10	1422 - 10	8	19'-6"	10'	11-1/2	87	330	1022	1105
12	1421 - 12	1422 - 12	8	19'-6"	†	11-1/2	104	330	1022	1105
16	1421 - 16	1422 - 16	8	38'-6"	†	13-5/8	68	710	1600	1681
20	1421 - 20	1422 - 20	8	39'	†	17-1/4	87	731-1/2	1950	2110
24	1421 - 24	1422 - 24	8	39'	†	17-1/4	104	731-1/2	1950	2110

ALL HEADROOM DIMENSIONS DETERMINED WHILE HOIST UNDER LOAD.

† Straight track operation only recommended for these units.

†† Curves less than minimum may be fitted by special construction. Consult factory.

Curve radius must be specified on order since wheels are modified to negotiate curves.



◀ STANDARD MODEL

**SPARK-RESISTANT OPTIONS**

**SOLID BRONZE HOOK, BOTTOM BLOCK, BRAKE RATCHET AND TROLLEY WHEELS**

**STAINLESS STEEL LOAD CHAIN**

**ALUMINUM OR STAINLESS STEEL HAND CHAIN**

**CORROSION-RESISTANT OPTIONS**

**SPECIAL CORROSION-RESISTANT FINISHES**

Created specifically for operation in salt-laden or other corrosive environments.

**CLEAN ROOM OPTIONS**

**STAINLESS STEEL COMPONENTS**

**GREASE-TIGHT ENCLOSURE WITH FOOD-GRADE LUBRICANT**

**FOOD-GRADE EPOXY FINISH**

**OPTIONAL FEATURES**

**TRACK CLAMPS**

**LOAD LIMITERS**

**CHAIN CONTAINERS**

**SPARK AND CORROSION RESISTANCE**

**POSITIVE ENGAGEMENT RACK & PINION OR SPROCKET & ROLLER CHAIN TROLLEY DRIVES**

Available for use on inclined monorails or for shipboard use to provide increased control over the trolley to prevent unintended movement.



◀ SPARK-RESISTANT MODEL

## ZEPHYR LOW-HEADROOM TROLLEY HOISTS

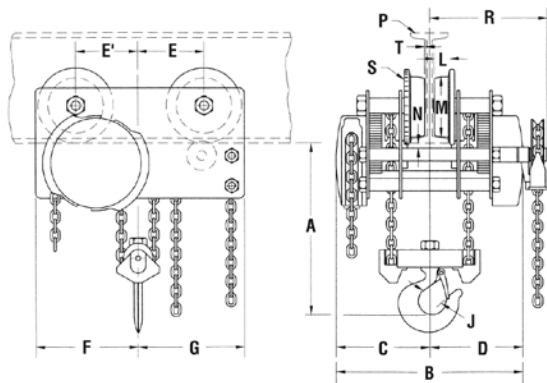

PLAIN & GEARED

### DIMENSIONS

Capacity (tons)	Dimensions (In.)															
	A	B	C	D	E	E'	F	G	H	J	L	M	N**	P*	R	S
<b>PLAIN &amp; GEARED TROLLEY HOIST</b>																
1-1/2	6-1/4	20-3/8	10-3/16	10-3/16	5-1/8	5-1/8	8-3/4	8-1/4	5/8	1-1/8	1-1/8	4-1/2	1/2	6" I @ 12.5#	13-1/16	6
2	6-1/4	20-3/8	10-3/16	10-3/16	5-1/8	5-1/8	8-3/4	8-1/4	5/8	1-1/8	1-1/8	4-1/2	1/2	6" I @ 12.5#	13-1/16	6
3	7-3/8	20-3/8	10-3/16	10-3/16	6-1/2	6-5/8	10-5/8	10-5/8	9/16	1-11/32	1-11/32	6-3/8	1/2	8" I @ 18.4#	13-1/16	8
4	8	20-3/8	10-3/16	10-3/16	6-1/2	6-5/8	10-5/8	10-5/8	9/16	1-11/16	1-11/32	6-3/8	1/2	8" I @ 18.4#	13-1/16	8
5	8-3/4	26-1/4	13-1/8	13-1/8	7-3/8	7-3/8	12	12	29/32	1-11/16	1-13/32	7-3/16	9/16	10" I @ 25.4#	16-1/2	9
6	8-3/4	26-1/4	13-1/8	13-1/8	7-3/8	7-3/8	12	12	29/32	1-11/16	1-13/32	7-3/16	9/16	10" I @ 25.4#	16-1/2	9
8	11	26-1/4	13-1/8	13-1/8	8-3/8	8-7/8	14	13-1/2	9/16	2-1/16	1-11/16	8-1/4	9/16	10" I @ 25.4#	16-1/2	10
10	11-1/2	26-1/4	13-1/8	13-1/8	8-1/2	9-3/4	15-5/8	14-3/8	9/16	2-1/4	1-3/4	9-3/4	5/8	12" I @ 31.8#	16-1/2	11-11/16
12	11-1/2	26-1/4	13-1/8	13-1/8	8-1/2	9-3/4	15-5/8	14-3/8	9/16	2-1/4	1-3/4	9-3/4	5/8	12" I @ 31.8#	16-1/2	11-11/16
16	13-5/8	30-3/8	15-3/16	15-3/16	11-7/8	11-7/8	18-5/8	18-5/8	9/16	3	11-3/4	3/4	3/4	15" I @ 42.9#	18-7/8	13-1/2
20	17-1/4	30-3/8	15-3/16	15-3/16	12-1/8	12-3/8	19-1/4	19	3/4	3-5/8	2	11-3/4	5/8	18" I @ 54.7#	18-7/16	13-1/2
24	17-1/4	30-3/8	15-3/16	15-3/16	12-1/8	12-3/8	19-1/4	19	3/4	3-5/8	2	11-3/4	5/8	18" I @ 54.7#	18-7/16	13-1/2
<b>PLAIN &amp; GEARED TROLLEY HOIST, SPARK-RESISTANT</b>																
1-1/2	7-3/8	20-3/8	10-3/16	10-3/16	5-1/8	5-1/8	8-3/4	8-1/4	5/8	1-11/32	1-1/8	4-1/2	1/2	6" I @ 12.5#	13-1/16	6
2	7-3/8	20-3/8	10-3/16	10-3/16	5-1/8	5-1/8	8-3/4	8-1/4	5/8	1-11/32	1-1/8	4-1/2	1/2	6" I @ 12.5#	13-1/16	6
3	8-7/16	20-3/8	10-3/16	10-3/16	6-1/2	6-5/8	10-5/8	10-5/8	9/16	1-11/16	1-11/32	6-3/8	1/2	8" I @ 18.4#	13-1/16	8
4	9-15/16	20-3/8	10-3/16	10-3/16	6-1/2	6-5/8	10-5/8	10-5/8	9/16	2-7/32	1-11/32	6-3/8	1/2	8" I @ 18.4#	13-1/16	8
5	10-5/16	26-1/4	13-1/8	13-1/8	7-3/8	7-3/8	12	12	29/32	2-7/32	1-13/32	7-3/16	9/16	10" I @ 25.4#	16-1/2	9
6	11-3/8	26-1/4	13-1/8	13-1/8	7-3/8	7-3/8	12	12	29/32	2-1/4	1-13/32	7-3/16	9/16	10" I @ 25.4#	16-1/2	9
8	14-1/16	26-1/4	13-1/8	13-1/8	8-3/8	8-7/8	14	13-1/2	9/16	3-1/32	1-11/16	8-1/4	9/16	10" I @ 25.4#	16-1/2	10
10	14-7/16	26-1/4	13-1/8	13-1/8	8-1/2	9-3/4	15-5/8	14-3/8	9/16	3-1/32	1-3/4	9-3/4	5/8	12" I @ 31.8#	16-1/2	11-11/16
12	16-1/8	26-1/4	13-1/8	13-1/8	8-1/2	9-3/4	15-5/8	14-3/8	9/16	3-1/4	1-3/4	9-3/4	5/8	12" I @ 31.8#	16-1/2	11-11/16
16	19-5/16	30-3/8	15-3/16	15-3/16	11-7/8	11-7/8	18-5/8	18-5/8	9/16	3-3/8	2	11-3/4	3/4	15" I @ 42.9#	18-7/8	13-1/2
20	20-1/4	30-3/8	15-3/16	15-3/16	12-1/8	12-3/8	19-1/4	19	3/4	3-3/8	2	11-3/4	5/8	18" I @ 54.7#	18-7/16	13-1/2
24	20-1/4	30-3/8	15-3/16	15-3/16	12-1/8	12-3/8	19-1/4	19	3/4	3-3/8	2	11-3/4	5/8	18" I @ 54.7#	18-7/16	13-1/2

For over 10 Ton, straight track operation is recommended.

Curve radius must be specified on orders.

Curves less than minimum radius may be fitted upon application.

\* Minimum Standard I-Beam for Proper Wheel Running Clearance Only.

\*\* At Under Beam Roller

Customer must verify their beam is adequate for the applied loads.