

Ratchet Lever



OPERATING, MAINTENANCE
& PARTS MANUAL

HAND-OPERATED LEVER HOIST

COFFING[®]
HOISTS

LSB-C Series

LEVER CHAIN HOIST

Before installing hoist, fill in the information below.

Rated Load _____

Serial No. _____

Purchase Date _____

Rated Loads:

3/4, 1, 1-1/2, 3 and 6 Tons

(750, 1000, 1500, 3000 and 6000 kg)

Follow all instructions and warnings for inspecting, maintaining and operating this hoist.

The use of any hoist presents some risk of personal injury or property damage. That risk is greatly increased if proper instructions and warnings are not followed. Before using this hoist, each operator should become thoroughly familiar with all warnings, **instructions and recommendations in this manual. Retain this manual for future reference and use.** Forward this manual to operator.

Failure to operate equipment as directed in manual may cause injury.



P/N: 192090087 REV. AA October 2021

COFFING HOIST PARTS AND SERVICES ARE AVAILABLE IN THE UNITED STATES AND IN CANADA

As a Coffing hoist and trolley user, you are assured of reliable repair and parts services through a network of Master Parts Depots and Service Centers that are strategically located in the United States and Canada. These facilities have been selected for their demonstrated ability to handle all parts and repair requirements promptly and efficiently. To quickly obtain the name of the Master Parts Depot or Service Center nearest you, call (800) 888-0985. Fax: (716) 689-5644.

WARNING

Improper operation of a hoist can create a potentially hazardous situation which, if not avoided, could result in death, or serious injury. To avoid such a potentially hazardous situation, the operator shall:

1. **not** operate a malfunctioning or unusually performing hoist.
2. **not** operate the hoist until you have thoroughly read and understood this manual.
3. **not** operate a hoist which has been modified without the manufacturer's approval or certification to be in conformity with applicable OSHA regulations.
4. **not** lift or pull more than rated load for the hoist.
5. **not** use damaged hoist or hoist that is not working properly.
6. **not** use hoist with twisted, kinked, damaged, or worn load chain.
7. **not** operate with any lever extension (cheater bar).
8. **not** attempt to "free chain" the hoist while a load is applied.
9. **not** use the hoist to lift, support, or transport people.
10. **not** lift loads over people and make sure all personnel remain clear of supported load.
11. **not** attempt to lengthen the load chain or repair damaged load chain.
12. Protect the hoist's load chain from weld splatter or other damaging contaminants.
13. **not** operate a hoist when it is restricted from forming a straight line from hook to hook in the direction of loading.
14. **not** use load chain as a sling or wrap load chain around load.
15. **not** apply the load to the tip of the hook or to the hook latch.
16. **not** apply load unless load chain is properly seated in the chain wheel(s) or sprocket(s).
17. **not** apply load if bearing prevents equal loading on all load-supporting chains.
18. **not** operate beyond the limits of the load chain travel.
19. **not** leave load supported by the hoist unattended unless specific precautions have been taken.
20. **not** allow the chain or hook to be used as an electrical or welding ground.
21. **not** allow the chain or hook to be touched by a live welding electrode.
22. **not** remove or obscure the warnings on the hoist.
23. **not** operate a hoist that has not been securely attached to a suitable support.
24. **not** operate a hoist unless load slings or other approved single attachments are properly sized and seated in the hook saddle.
25. **not** lift loads that are not balanced and the holding action is not secure, taking up slack carefully.
26. **not** operate a hoist unless all persons are and remain clear of the supported load.
27. Report malfunctions or unusual performances of a hoist. Shut it down and forbid its use until it has undergone repair.
28. **not** operate a hoist on which the safety placards or decals are missing or illegible.
29. Be familiar with operating controls, procedures and warnings.

CAUTION

Improper operation of a hoist can create a potentially hazardous situation which, if not avoided, could result in minor or moderate injury. To avoid such a potentially hazardous situation, the operator shall:

1. Maintain a firm footing or be otherwise secured when operating the hoist.
2. Check brake function by tensioning the hoist prior to each lift or pulling operation.
3. Use hook latches. Use latches to retain slings, chains, etc., under slack conditions only.
4. Make sure the hook latches are closed and not supporting any parts of the load.
5. Make sure the load is free to move and will clear all obstructions.
6. Avoid swinging the load or hook.
7. Avoid lever "fly-back" by keeping a firm grip on the lever until operating stroke is completed and lever is at rest.
8. Inspect the hoist regularly, replace damaged or worn parts, and keep appropriate records of maintenance.
9. Use Columbus McKinnon parts when repairing the unit.
10. Lubricate load chain as recommended in this manual.
11. **not** operate hoist except with manual power.
12. **not** permit more than one operator to pull on lever at the same time. More than one operator is likely to indicate hoist overload.
13. **not** allow your attention to be diverted from operating the hoist.
14. **not** allow the hoist to be subjected to sharp contact with other hoists, structures, or objects through misuse.
15. **not** adjust or repair the hoist unless qualified to perform such adjustments or repairs.

The hoists are intended for general industrial use for moving loads within their load ratings. Prior to installation and operation, the user should review the application for abnormal environmental or handling conditions.

GENERAL SAFETY INFORMATION

ADVERSE ENVIRONMENTAL CONDITIONS

Do not use the hoists in areas containing flammable vapors, liquids, gasses or any combustible dust or fibers. Do not use the hoist in highly corrosive, abrasive, wet environments or in applications involving exposure to temperatures below -10°F or above 130°F.

MOVING HAZARDOUS LOADS

The hoists are not recommended for lifting materials that could cause widespread damage if dropped. The lifting or moving of materials that could explode or cause chemical or radioactive contamination requires fail-safe, redundant supporting devices that are not incorporated into these hoists.

DESCRIPTION

The Coffing® LSB-C hand-operated lever hoists are highly versatile tools that can be used in any position to efficiently pull, lift, drag or stretch. Lever hoists are made of the best selected materials to provide long, dependable service for users. Coffing lever hoists are manufactured and processed through up-to-date streamlined production facilities by skilled engineers under strict quality control.

This manual applies to hoists with load ratings of 3/4, 1, 1-1/2, 3 and 6 tons. The hoists are available with 5-, 10-, 15- and 20-foot lifts.

Hooks with latches are standard on all units.

The Coffing® LSB-C hand-operated lever hoists are built in accordance with the specification contained herein and at the time of manufacture comply with the applicable sections of the American Society of Mechanical Engineers (ASME) Standard B30.21: Manually Operated Lever Hoists.

Certification Statement

This is to certify that the accompanying Coffing Hoist(s) has (have) been tested at 125% of rated capacity and inspected in accordance with ASME/ANSI B30.21. Do not exceed rated capacity stated on the hoist. Refer to manual for operating instructions and forward manual to operator.

SPECIFICATIONS

Model LSB-C Lever Hoist

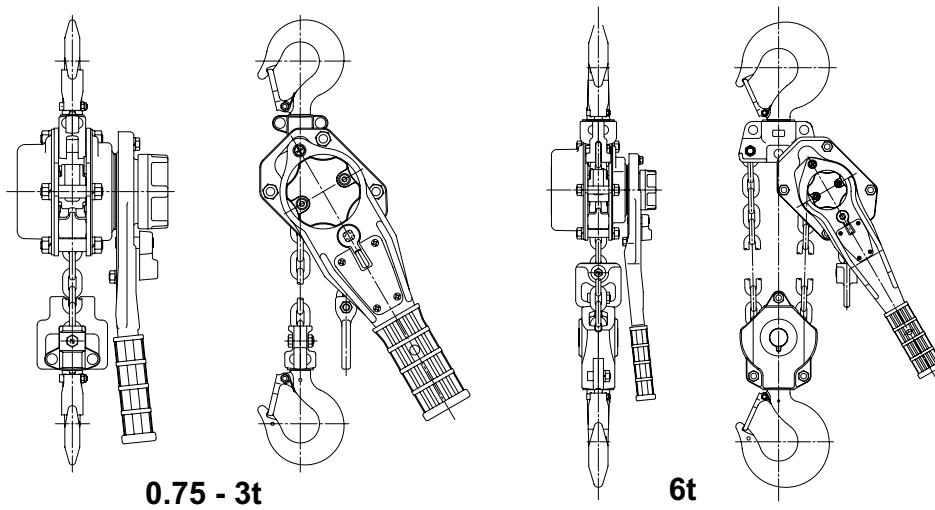

Model	Rated Capacity		Test Load (150% Rated*)		Standard Lifts		Load Chain Details			Less Chain Unit Weight		Distance between Hooks		Pull Force @ Rated Load		Length of Handle	
	ton	kg	ton	kg	ft	m	Chain dia. (mm)	Reeving	Weight / Chain Length lb / ft	lb	kg	in	mm	lb	N	in	mm
LSB-1500C	0.75	750	1.125	1125	5, 10, 15, 20	1.5, 3, 4.5, 6	Ø5.6	1	0.446	9.7	4.4	15.26	388	46	205	9.35	237
LSB-2000C	1	1000	1.5	1500	5, 10, 15, 20	1.5, 3, 4.5, 6	Ø5.6	1	0.446	10.1	4.6	16.16	410	58	256	9.35	237
LSB-3000C	1.5	1500	2.25	2250	5, 10, 15, 20	1.5, 3, 4.5, 6	Ø7.1	1	0.731	16.8	7.6	19.17	487	66	293	10.10	257
LSB-6000C	3	3000	4.5	4500	5, 10, 15, 20	1.5, 3, 4.5, 6	Ø9	1	1.179	28.9	13.1	24.17	614	75	333	14.63	372
LSB-12000C	6	6000	7.5*	7500*	5, 10, 15, 20	1.5, 3, 4.5, 6	Ø9	2	1.179	53.1	24.1	28.18	716	76	337	14.63	372

*125% Rated Load

Table 1: Specifications

UNPACKING

After unpacking the hoist, inspect carefully for any damage that may have occurred during transit. Check for loose, missing or damaged parts. Shipping damage claims must be filed with carrier. Lubricate the load chain along the entire length with machine oil.

COFFING® REPAIR/REPLACEMENT POLICY

All Columbus McKinnon (Coffing) LSB-C hoists are inspected and performance tested prior to shipment. If any properly maintained hoist develops a performance problem during the life of the goods (due to a material or workmanship defect, as verified by Coffing), Coffing will repair or replace the unit for the original purchaser without charge.

This repair/replacement policy applies only to Coffing LSB-C hoists installed, maintained and operated as outlined in this manual, and specifically excludes hoists subject to normal wear, abuse, improper installation, improper or inadequate maintenance, hostile environmental effects and unauthorized repairs/modifications. We reserve the right to change materials or design if, in our opinion, such changes will improve our product. Abuse, repair by an unauthorized person, or use of non-Coffing replacement parts voids the guarantee and could lead to dangerous operation. For full Terms of Sale, see Sales order Acknowledgement. Also, refer to the Limitations of Warranties, Remedies and Damages, and indemnification and Safe operation.

INSTALLATION

Before installing the hoist:

1. Estimate the weight of the load to be lifted or moved and make sure it does not exceed the rated load of the hoist.
2. Make sure the support or sling to which the upper hook is attached is strong enough to hold several times the weight of the load to be lifted or moved. Be sure the hoist is solidly held in the uppermost part of the upper hook and the latch is closed and not in contact with the support or sling.
3. Examine the load chain to ensure that there is no twist. When your lever hoist is a 6-ton unit that lifts on 2 falls of load chains, twists can arise from the bottom hook accidentally turning over through the load chains.
4. The area in which the hoist is installed must provide sufficient room for:
 - The operator to operate the lever.
 - The operator and other personnel to stand clear of the load at all times.
 - Firm footing for the operator.



- Clearance between the hoist frame and any object. The frame must be free to swivel on the upper hook.

⚠ WARNING

Attaching the hoist from an inadequate support may allow the hoist and load to fall and cause injury and/or property damage.

TO AVOID INJURY:

Make sure the structure has sufficient strength to hold several times the hoist weight and its rated load.



OPERATION

⚠ WARNING

If not used as directed, lever hoist may cause injury.

TO AVOID INJURY:

Use only as directed below. Read all instructions before operating the Coffing LSB-C hand-operated lever hoist.

GENERAL

1. Keep the hoist clean to assure proper operation. Before use, check to be sure the load chain is clean, that there is no foreign material in the liftwheel area and that the lever operates freely.
2. Do not load beyond the rated capacity. Overload can cause immediate failure or cause damage resulting in future failure, even at less than rated capacity.
3. Do not use this hoist or any other material handling equipment for lifting or moving people, or lifting loads over people.
4. Stand clear of all loads and warn other people of your intention to move a load in their area.
5. Do not leave a load on the unit unattended.
6. Read warnings and instructions on the hoist before each use.
7. Do not hold the load chain while operating the hoist. Should the hoist not operate properly, serious injury may occur.
8. Never operate the hoist when flammable materials or vapors are present. Contact between metal parts may produce sparks that can cause a fire or explosion.
9. **Stay alert!** Watch what you are doing and use common sense. Do not use the hoist when you are tired, distracted or under the influence of drugs, alcohol or medication causing diminished control.

⚠ WARNING

Malfunction of unit, rigging slip or loss of footing may cause user to slip, resulting in injury.

TO AVOID INJURY:

Always have a firm and secure footing when using the Coffing LSB-C hand-operated lever hoist.

OPERATION (CONTINUED)

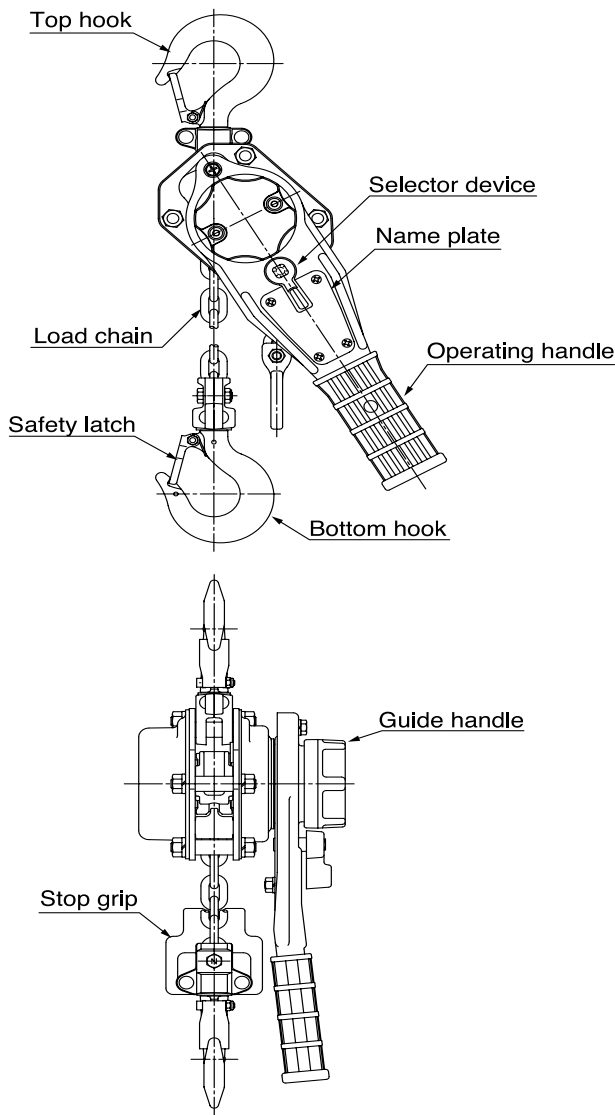

Figure 1: Lever Hoist

ATTACHING THE LOAD

Attach the lower hook to the load so that it is seated in the bowl of the hook and is not bearing against the tip of the hook or latch. Ensure that the latch is tight against the hook tip.

WARNING

Allowing the load to bear against the hook latch and/or hook tip can result in loss of load.

TO AVOID INJURY:

Do not allow the load to bear against the hook latch and/or hook tip. Apply load to hook bowl or saddle only.

Do not wrap the chain around the load and hook onto itself as a choker chain sling and never bring the load in contact with the hoist. Doing this will result in the loss of the swivel effect of the hook, which could cause a twisted chain and a jammed lift-wheel. Also, the chain may be damaged at the hook. Make sure the upper and lower hooks are in a straight line and the frame is free to swivel on the upper hook.

HOISTING (PULLING) AND LOWERING (RELEASING)

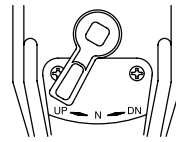

Figure 2:
Lifting

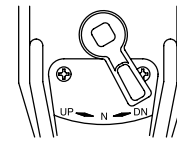

Figure 3:
Lowering

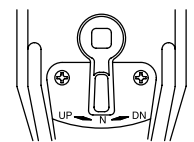

Figure 4:
Free-Wheeling

When pulling or lifting, move the load only enough to slightly load the unit, then check to be sure that the attachments to the hooks and load are firmly seated. Continue movement only after you are assured the load is free of all obstructions. Lift loads as slowly as possible. Load swinging and abrupt shocks will impose on the lever hoist excessive burdens that may more than double the weight of the load.

Hoisting (Pulling)

See Figure 2. Set the selector lever to the "UP" position. Take up the slacked load chain by turning the guide handle clockwise. Next, manipulate the operating handle clockwise.

Lowering (Releasing)

See Figure 3. Set the selector lever to the "DOWN" position. Manipulate the operating handle counterclockwise. When there is no load on the lever hoist, the load chain can be slacked by turning the guide handle counterclockwise.

The hoist has been designed for hand powered operation only. Do not use an extension on the lever. Any pound-force greater than the following pound-forces indicates an overload or incorrect maintenance:

- Pound-force over 67.5 for the 3/4-ton unit
- Pound-force over 84 for the 1-ton unit
- Pound-force over 96 for the 1-1/2-ton unit
- Pound-force over 103 for the 3-ton unit
- Pound-force over 116 for the 6-ton unit

WARNING

Power operation may cause structural damage or premature wear that in turn may cause a part to break and allow the load to fall.

TO AVOID INJURY:

Operate the Coffing LSB-C lever hoist using hand power only!

FREE-CHAINING

See Figure 4. In this mode of operation, pull the chain through the hoist in either direction by hand for quick attachment to the load.

To engage the free-chaining feature, remove any load from the hoist, move the directional lever to the ("N") position, and pull the load chain out in the desired direction.

Free-chaining will not be possible during the following conditions:

1. When the lever hoist is under a load.
2. When the guide handle is in contact with something and not rotating freely.
3. When the brake has locked from a large or abrupt shock load: Turn the guide handle 45 degrees counterclockwise to unlock the brake.

- When the brake is locked: Unlock the brake by setting the selector lever to the "DOWN" position and manipulating the operating handle counterclockwise.

⚠ WARNING
Turning the free-chaining knob with a load attached will allow the load to release and may cause injury.
TO AVOID INJURY: Never turn the free-chaining knob when the lever hoist is under load.

LOCKED BRAKE

The lever hoist will automatically change from the free-chaining condition to the brake locked condition when a load is applied. Apply the load with one of the following two methods:

- Turn the guide handle clockwise until the brake locks from the force of the load.
- Pull firmly on the stop grip until the brake locks from the force of the load (See Figure 5).

Next, turn the selector lever to the "UP" position and hoist or pull by manipulating the operating handle.

⚠ WARNING
If the unit is not rigged in a straight line hook to hook, and if the frame is not free to swivel, the lever pull may break the frame and cause physical injury and loss of load.
TO AVOID INJURY: Rig the unit in a straight line hook to hook and ensure the frame swivels freely (See Figure 5).

INSPECT HOIST

Inspect it before each use and at specified intervals as directed in the inspection section (See page 8).

⚠ WARNING
Use as directed above. Failure to do so may cause injury to you or others.

- Do not** exceed the capacity shown on the nameplate.
- Do not** use the hoist to lift people or to lift loads over people.
- Do not** use the unit unless the hoist's frame and chain form a straight line between hooks.
- Do not** use hoist if the frame contacts any object.
- Do not** use the hoist if the unit is damaged or malfunctions.
- Do not** use the hoist extension on the lever. Use hand power only.
- Do not** use the hoist if the chain is twisted, kinked or damaged.

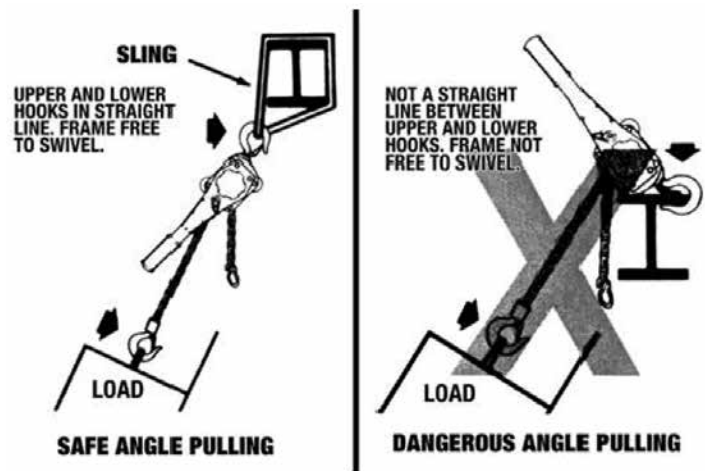

Figure 5: Pulling at an Angle

MAINTENANCE

INSPECTION

To maintain continuous and satisfactory operation, regularly inspect the unit and replace worn or damaged parts before they become unsafe. Determine the intervals of inspection based on the individual application and also the type of service to which the hoist is subjected. The intervals indicated as follows are based on normal service.

Divide inspections into two general classifications (frequent and periodic).

FREQUENT INSPECTIONS

The operator conducts these visual examinations daily or before each use, including:

1. Braking mechanism for evidence of slippage.
2. Operation of the directional lever for free movement.
3. Load chain for lubricant, wear, damaged links or foreign material.
4. Hooks for damage, cracks, twists, latch engagement and latch operation.

PERIODIC INSPECTIONS

A designated person conducts visual inspections of external and internal conditions, making records to provide the basis for continuing evaluation of the condition of the hoist. Determine the frequency of periodic inspections based upon usage as defined in ASME B30.21. Periodic inspections should include those items as well as the following:

1. Chain for excessive wear or stretch
(See Figures 7 thru 8, starting on page 8).
2. Worn, cracked or distorted parts such as lower hook block, upper hook block, upper hook pin, chain guide, bushings, lever, brake cover, free-chaining knob, directional pawl, friction hub and lever ratchet.
3. Inspect for wear on the tip of the pawls, teeth of the ratchet, and pockets of the lift-wheel.
4. Loose or missing bolts, nuts, pins or rivets.
5. Inspect the brake components for worn, glazed or contaminated friction discs and scoring of the friction hub and ratchet. Replace brake ratchet assembly if contaminated, glazed or if thickness is less than the following thickness:
 - 0.256 in. (6.5 mm) for 3/4-ton and 1-1/2-ton units
 - 0.307 in. (7.8 mm) for 3-ton and 6-ton units
6. Corroded, stretched or broken pawl springs, directional lever pawl spring and lever ratchet spring.
7. Hooks – Visual inspection based upon ASME B30.10 and ASME B30.21.
8. Nameplate and warning labels for legibility and retention.
9. Chain stop in place and properly secured.

Correct any deficiency before returning the hoist to service. Also, the external conditions may show the need for more detailed inspection which, in turn, may require the use of non-destructive type testing.

Replace any parts deemed unserviceable, using new parts before returning the hoist to service. Destroy unserviceable parts and properly dispose of them to prevent any future use of them.

When the unit is subjected to heavy usage or dusty, gritty, moist or corrosive atmospheric conditions, assign shorter time periods between inspections. Inspect all parts for unusual wear, corrosion or damage, in addition to those specifically mentioned in the schedule.

HOOK INSPECTION

Replace hooks that have suffered damage from chemicals, deformations or cracks, or that have a twist from the plane of the unbent hook, excessive opening or seat wear (see ASME B30.10). Also, replace hooks that are opened to the extent that the latch does not engage the tip. Any hook that is twisted or has excessive throat opening indicates abuse or overloading of the hoist. Inspect other load-sustaining parts for damage.

Check to assure the latch is not damaged or bent and that it operates properly. The latch should have sufficient spring pressure to keep it tightly against the tip of the hook and allow it to spring back to the tip when released. Replace the latch if it does not operate properly.

Use the chart below Figure 6 to determine when the hook needs replacing.

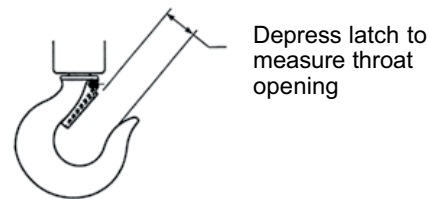

Figure 6: Hook Inspection

Rated Load		Standard Throat Opening
(lb)	(Ton)	in. (mm)
1500	3/4	1.10 (21)
2000	1	1.25 (22)
3000	1-1/2	1.37 (26)
6000	3	1.44 (31)
12000	6	2.00 (46)

Table 2: Hook Replacement

NOTE: Hook should be frequently inspected to ensure that any distortion causing an increase to throat opening does not exceed 10%.

LOAD CHAIN

The chain should feed smoothly into and away from the hoist. If the chain binds, jumps or produces noise, first clean and lubricate it (See Chain Lubrication on Page 9). If trouble persists, inspect the chain and mating parts for wear, distortion or other damage.

CHAIN INSPECTION

First clean the chain with a non-caustic/non-acid type solvent and conduct a link-by-link inspection for nicks, gouges, twisted links, weld spatter, corrosion pits, striations (minute parallel lines), cracks in weld areas, wear and stretching. Replace the chain if it has any one of the defects shown in Figure 7.

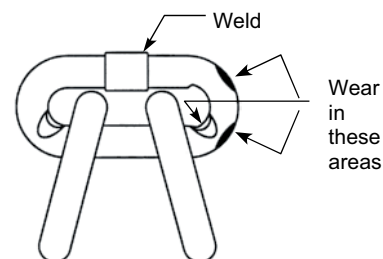

Figure 7: Chain Inspection

MAINTENANCE (CONTINUED)

Slack the portion of the chain that normally passes over the lift-wheel. Examine the interlink area for the point of maximum wear (polishing). Measure and record the stock diameter at this point of the link. Then measure stock diameter in the same area on the link that does not pass over the lift-wheel (use the link adjacent to the chain stop for this purpose). If the measurements do not follow the measurements in Figure 8, replace the chain.

Hoist Capacity (Tons)	Diameter (mm)	Standard Size (in.)	Limit (in.)
3/4 and 1	5.6	6.732	6.866
1-1/2	7.1	8.346	8.511
3	9	10.709	10.923
6	9	10.709	10.923

Table 3: Chain Measurements

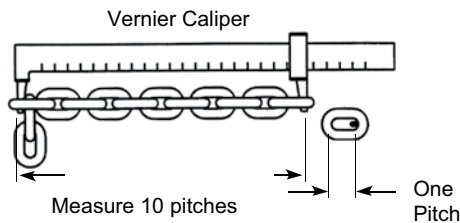

Figure 8: Chain Inspection

Check the chain for stretch using a vernier caliper as shown in Figure 8. Select an unused, unstretched section of chain (usually at the loose end) and measure and record the length over 11 chain links (pitches). Measure and record the same length on a worn section of chain.

If the amount of stretch and wear exceeds 0.145 in. (3.7 mm), replace the chain.

Use only a “knife-edge” caliper to eliminate the possibility of a false reading by not measuring the full pitch length.

WARNING

Using other than a Coffing-supplied load chain may cause the chain to jam in the hoist and/or allow the chain to break and the load to drop.

TO AVOID INJURY

Due to size requirements and physical properties, use only Coffing Supplied LSB-C supplied load chain in the LSB-C lever hoist.

Note that a worn chain can indicate worn hoist components. Examine the hoist’s frame, stripper, and lift-wheel for wear and replace it as necessary when replacing worn chain.

Also, the load chain is specially heat treated and hardened and should never be repaired.

Important: Do not use a replaced chain for other purposes such as lifting or pulling. The load chain may break suddenly without any visual deformation. For this reason, cut replaced chain into short lengths to prevent its use after disposal.

CHAIN LUBRICATION

A small amount of lubricant will greatly increase the life of the load chain. Do not allow the chain to run dry. Keep it clean and lubricate at regular intervals with SAE 20-30 machine oil or equivalent lubricant. Normally, weekly lubrication and cleaning is satisfactory, but under hot and dirty conditions, it may be necessary to clean the chain at least once a day and lubricate it several times between cleanings.

WARNING

Used motor oils contain known carcinogenic materials.

TO AVOID INJURY:

Never use used motor oils as a chain lubricant. Only use SAE 20-30 machine oil as a lubricant for the load chain.

When lubricating the chain, apply sufficient lubricant to obtain natural run-off and full coverage, especially in the interlink area.

Hoist normally requires no additional lubrication except when it has been disassembled for cleaning or repairs.

Important: The brake is designed to operate dry. Do not use any grease or lubricant on the braking surfaces.

When lubricating parts adjacent to the brake, do not use an excessive amount of lubricant, which could seep onto the brake surfaces.

WARNING

Using any grease or lubricant on the braking surfaces will cause brake slippage and loss of load control, which may result in injury and/or property damage.

TO AVOID INJURY:

Do not use any grease or lubricant on braking surfaces. The brake is designed to operate dry.

MAINTENANCE (CONTINUED)

OPTIONAL LOAD LIMITER

The LSB-C lever hoist has an optional load limiter, a device that is designed and calibrated to prevent excessive overloads. Excessive overload is indicated by lever hook movement without the corresponding movement of the lower hook block or load when the unit is operated in the “UP” direction. If overload exists, immediately switch the lever to the “DOWN” position and operate the lever to remove the excess load from the units.

Reducing the load to the rated capacity or less will automatically restore the normal operation of the unit. To convert a standard LSB-C lever hoist to a unit with the overload protection, replace reference no. 80 (See Figure 9).

Refer to chart below for the appropriate load limiter for your capacity hoists.

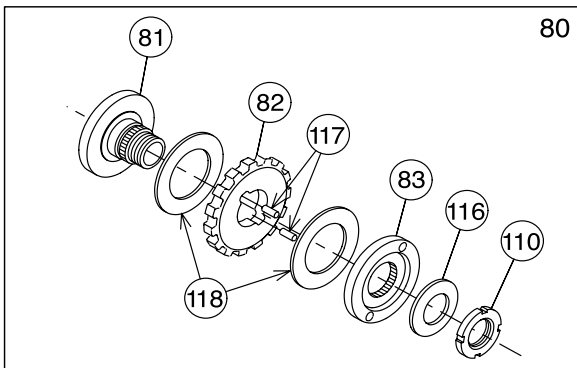

Figure 9: Overload Protection Device

Hoist Capacity (Tons)	Part No.	Ket Part Number
3/4	80	IRB5080U
1	80	JRB5080U
1-1/2	80	KRB5080CU
3	80	NRB5080U
6	80	QRB5080U

Table 4: Overload Protection Kits

The load limiter may require adjustment when it slips at or below the rated load. Refer to chart below for the correct torque setting for the load limiter. Only adjust the load limiter by item 110 in Figure 9. If the load limiter cannot be corrected by adjusting the torque setting or if any of the parts are damaged, replace the load limiter. A special tool is required to adjust Item 110 properly (Contact factory).

Hoist Capacity (Tons)	Torque Range (ft-lbs)
LSB1500B	28-32
LSB3000B	59-66
LSB6000B	77-85
LSB1500B	77-85

Table 5: Torque Range

NOTE: Excessive torque will damage the load limiter and could cause equipment damage or personal injury.

CAUTION

The load limiter is subject to overheating and wear when excessively actuated. For this reason, once overloading is detected, remove the excess load, restore normal operation, and watch for any continued undue operation.

The load limiter is designed to operate dry, without lubrication. To ensure proper operation, DO NOT apply lubricant to the friction surfaces or to adjacent parts of the load limiter.

TESTING

Test the load limiter during periodic inspections. To perform this test, attach the lower hook to a load at maximum 200% of rated capacity and operate the unit in the “UP” direction. When attempting to lift the load, the lever should slip. After this test, move the trigger to the “DOWN” position and operate the unit to remove the tension from the units. Once tension releases, the unit should return to normal operation. If the load does not slip at 200% of capacity, replace the load limiter.

RECOMMENDED SPARE PARTS

- Ratchet Disc Assembly
- Latch Kit
- Upper & Lower Hook Assembly

WARNING

Alterations or modifications of equipment and use of any parts other than Coffing LSB-C lever hoist repair parts can lead to dangerous operation and injury.

TO AVOID INJURY:

Do not alter or modify equipment. Only use replacement parts provided by Coffing LSB-C.

PREVENTATIVE MAINTENANCE

In addition to conducting inspections, establish a preventative maintenance program to prolong the useful life of the hoist and maintain its dependability and continued safe use.

The program should include periodic inspections focusing on lubricating various components using the recommended lubricants (See Table 7).

TESTING

Prior to initial use, the user should test all repaired or used hoists that have not been operated for the previous 12 months, checking for proper operation.

1. Test the unit first in the unloaded state.
2. Then test the unit with a light load of 100 lbs (45 kg) times the number of load-supporting parts of load chain to be sure it operates properly and the brake holds the load when the lever is released.
3. Then test the unit with a load of 125% of rated capacity.
4. In addition, test hoists in which load-sustaining parts have been replaced. Test them at 125% of rated capacity by or under the direction of a designated person and prepare a written report for record purposes.

NOTE: For additional information on inspection and testing, refer to ASME B30.21, “Manually Operated Lever Hoists” (obtainable from asme.org).

MAINTENANCE (CONTINUED)

Inspector Report	Torque Range (ft-lbs)	
ITEM	REMARKS (LIST DEFICIENCIES AND RECOMMENDED ACTION)	
Inspector's Signature	Date Inspected:	
	Approved by:	
	Date:	

Table 6: Recommended Inspectors Report

RECOMMENDED LUBRICATION SCHEDULE*					
COFFING LEVER OPERATED CHAIN HOIST					
PAGE NUMBERS	COMPONENT	TYPE OF LUBRICANT	TYPE OF SERVICE AND FREQUENCY OF LUBRICATION		
			HEAVY	NORMAL	INFREQUENT
See Pages 15-17	Load Chain	SAE 20-30 Machine Oil	Daily	Weekly	Monthly
See Pages 15-17	Load Pawl Shaft, Pinion Shaft, Gear & Bearings, Pinion & Gear Teeth	Multi-purpose Lithium base bearing grease	At periodic inspection (See Inspection & Maintenance Checklist)		
See Pages 15-17	Bottom Block Shaft, Bearing & Hook Swivel	SAE 20-30 Machine Oil	Monthly	Yearly	Yearly

(*) This lubrication schedule is based on a hoist operating in normal environmental conditions. Lubricate hoists more frequently if they operate in environments with excessive heat, corrosive fumes or vapors, abrasive dust, etc.

CAUTION - DO NOT LUBRICATE BRAKE AREA OF HOIST.

Table 7: Recommended Lubrication Schedule

MAINTENANCE (CONTINUED)

INSPECTION AND MAINTENANCE CHECKLIST HAND-OPERATED LEVER HOIST

Type of Hoist _____ Capacity (tons) _____
 Location _____ Original Installation Date _____
 Manufacturer _____ Manufacturer's Serial Number _____

Item	Frequency of Inspection		Possible Deficiencies	OK	Action Required
	Frequent	Periodic			
	Daily	Every 3 months to Annually as defined per ASME B30.21			
Load Chain	*	*	Inadequate lubrication, excessive wear or stretch, cracked/damaged or twisted links, corrosion or foreign substance		
Hooks	*	*	Excessive throat opening, bent or twisted more than 10 degrees damaged hook latch, wear, chemical damage, cracks		
Hook Retainers	*	*	Worn or damaged nuts, pins, washers, collars used to secure hook in load block housing		
Ratchet Handle Pawl & Load Pawl		*	Wear, cracks, broken teeth Wear, cracks, or binding		
Pawl Springs		*	Breaks, corrosion, loss of tension		
Retaining Rings		*	missing or loss of retention		
Pawl Stud		*	Excessive wear, pawl retention, looseness		
Sheave, Pinion Shaft, Chain Attachments		*	Distortion, cracks, excessive wear, damaged threads, buildup of foreign substances		
Gearing		*	Inadequate lubrication, distortion, cracks, worn or broken teeth		
Bearing, Shaft		*	Inadequate lubrication, distortion, cracks, excessive wear		
Housing, Load Block, Outrigger, Hook Swivels		*	Cracks, distortion, loose bolts, nuts or rivets. Internal buildup of foreign substances		
Nuts, Bolts, Rivets		*	Looseness, stripped or damaged threads		
Supporting Structure		*	Damage or wear that restricts ability to support imposed loads		
Capacity Plate, Decals		*	Missing, damaged or illegible		

NOTE: Refer to Maintenance and Inspection Sections of this manual for further details.

FREQUENCY OF INSPECTION

Frequent - indicates items requiring inspection **daily or before each use**. These inspections may be performed by the operator if properly designated.

Periodic - indicates items requiring inspection **every three months**. Inspections must be performed by or under the direction of a properly designated person. The exact period of inspection will depend on frequency and type of usage. Determination of this period will be based on the user's experience. The user should begin with a quarterly inspection and extend the periods to semi-annually or annually based on the user's quarterly experience.

NOTE: This inspection and maintenance checklist is in accordance with our interpretation of the requirements of the Safety Standard for Lever Hoists ASME B30.21. However, it is the ultimate responsibility of the employer/user to interpret and adhere to the applicable requirements of this safety standard.

Table 8: Recommended Inspection and Maintenance Checklist

TROUBLESHOOTING

Symptom	Possible Cause(s)	Corrective Action
Slip caused by ineffective braking.	<ol style="list-style-type: none"> 1. Worn-out friction discs. 2. Excessive oil on the braking surface. 3. Incorrect assembly of the brake system. 	<ol style="list-style-type: none"> 1. Replace with new frictions discs. 2. Disassemble and clean. 3. Assemble correctly. (See the following pages)
Load dropped while lowering.	<ol style="list-style-type: none"> 1. Damaged friction discs. 2. Foreign matter in the braking system. 	<ol style="list-style-type: none"> 1. Replace with new ones. 2. Disassemble and clean.
Jammed operating handle.	Over-tightening of the brake.	Operate the lever hoist as if lowering a load.
Noises during hoisting and lowering operation.	Wear or deformation of the load chain and load sheave.	Replace with new parts.
Operating handle becomes difficult to operate during lifting or lowering operation.	<ol style="list-style-type: none"> 1. Over-hoisting or over-lowering. 2. Twist in the load chain causing it to catch between load sheave and load chain guide. 	<ol style="list-style-type: none"> 1. Operate the hoist in the opposite direction. 2. Operate the hoist in the opposite direction and remove the twist from the load chain.

NOTE: Refer to pages 15-17 for parts lists.

REPAIR PARTS LIST

WARNING

Using "commercial" or other manufacturer's parts to repair the Coffing LSB-C hoist may cause load loss.

TO AVOID INJURY:

Use only Coffing-supplied replacement parts. Parts may look alike, but Coffing parts are made of specific materials or are processed to achieve specific properties.



ORDERING INSTRUCTIONS

The following information must accompany all correspondence orders for replacement parts:

1. Hoist model number from identification plate.
2. Serial number of the hoist stamped below identification plate.
3. Length of lift.
4. Part number of part from parts list.
5. Number of parts required.
6. Part name from parts list.

NOTE: When ordering replacement parts, order such items as nuts, bolts, cotter pins, etc. These items may be damaged or lost during disassembly or become unfit for future use because of deterioration.

COFFING LSB-C HAND-OPERATED LEVER HOIST

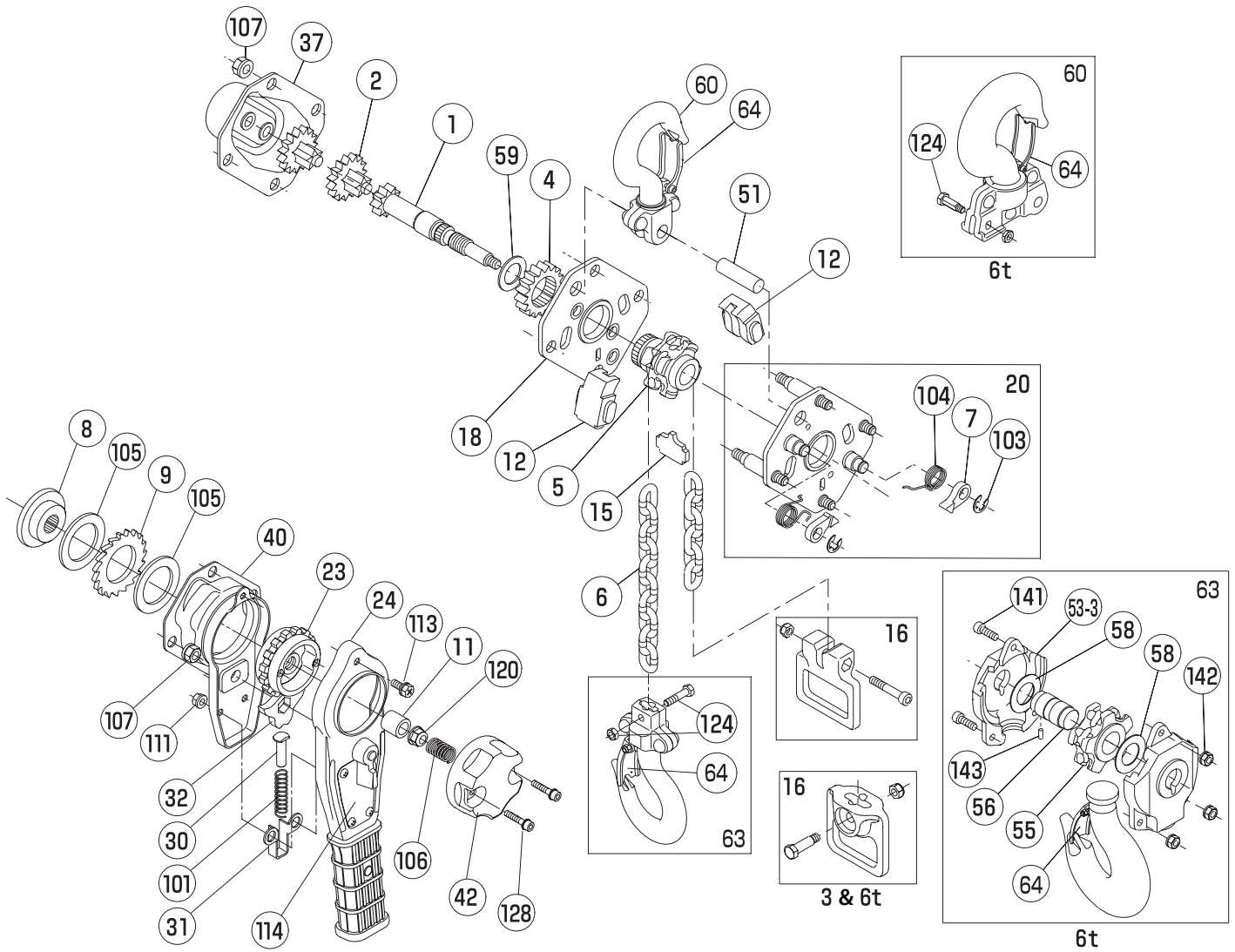

Coffing LSB-C Hand-Operated Lever Hoist

Part No.	Part Name	Qty.	0.75 ton	1 ton	1.5 ton Short Handle	3 ton	6 ton
1	Pinion Shaft	1	192090116		192090117	192090118	
2	Gear Assembly	2	192090119		192090120	192090121	
4	Load Gear	1	192090122	192090123	192090124	192090125	
5	Lift-wheel	1	192090126		192090127	192090128	
6	Load Chain	As Req'd	T56		KHH5009T	V9	
7	Pawl Spring	2	192090129		192090130		
8	Disc Hub	1	192090131		192090132		
9	Ratchet Wheel	1	192090133		192090134		
11*	Sleeve	1	192090135		192090136		
12	Chain Guide	2	192090137		192090138	192090139	
15	Chain Stripper	1	192090140		192090141	192090142	
16	Chain Stop Assembly	1	192090143		192090144	192090145	
18	Gear-Side Plate Assembly	1	192090146		192090147	192090148	
20	Lever-Side Plate Assembly	1	192090149		192090150	192090151	
23*	Disc Nut	1	192090152		192090153		
24	Operating Lever	1	192090154		192090155	192090156	
30	Spring Shaft	1	192090157		192090158		
31	Shaft Base	1	192090159		192090160		
32	Lever Directional Pawl	1	192090161		192090162		
37	Gear Cover	1	192090163		192090164	192090165	
40	Ratchet Cover	1	192090166		192090167	192090168	
42	Hand Wheel	1	192090169				
51	Yoke Pin	1	192090170		192090171	192090172	
53-3	Lower Hook Block	2	—		192090173		
55	Idle Sheave	1	—		192090174		
56	Sheave Shaft	1	—		192090175		
58	Collar for Idle Sheave Shaft	2	—		192090176		
59	Pinion Washer	1	192090177			192090178	
60	Top Hook Assembly	1	192090179	192090180	192090181	192090182	192090183
63	Bottom Hook Assembly	1	192090184	192090185	192090186	192090187	192090188
64	Safety Latch Kit*	2	192090189	192090190	192090191		192090192
101	Directional Pawl Spring	1	192090193		192090194		
103	Retaining Ring E-Clip	2	192090195		192090196		
104	Pawl Spring	2	192090197		192090198	192090199	
105	Brake Disc	2	192090200		192090201		
106	Free-wheel Spring	1	192090202		192090203	192090204	
107	Spring Nut	8	192090205			192090206	
111	Spring Nut	2	192090207		192090205		
113	Hex Phillips Bolt	1	192090208		192090209		
114	Nameplate	1	192090210	192090211	192090212	192090213	192090214
120	Flanged Nylon Locknut	1	192090215				
124	Chain Bolt Kit	1	192090216		192090217	192090218	

Part No.	Part Name	Qty.	0.75 ton	1 ton	1.5 ton Short Handle	3 ton	6 ton
128	Socket Head Cap Screw	2			192090219		
141	Socket Head Cap Screw	3		—			192090220
142	Spring Nut	3		—			192090221
143	Spring Pin	1		—			192090222
146	Warning Label**	1			192090223		

*Not included in units with Load Limiter.

**Not shown in the exploded views.

WARRANTY

LIMITATION OF WARRANTIES, REMEDIES AND DAMAGES

Note: When ordering parts, always furnish Rated Load, Voltage, Phase, Hertz and Serial Number of hoist on which the parts are to be used. For the location of the nearest Repair Station, see the list located on the inside front cover.

THE WARRANTY STATED BELOW IS GIVEN IN PLACE OF ALL OTHER WARRANTIES, EXPRESS OR IMPLIED, OF MERCHANTABILITY, FITNESS FOR A PARTICULAR PURPOSE, OR OTHERWISE, NO PROMISE OR AFFIRMATION OF FACT MADE BY ANY AGENT OR REPRESENTATIVE OF SELLER SHALL CONSTITUTE A WARRANTY BY SELLER OR GIVE RISE TO ANY LIABILITY OR OBLIGATION.

Seller warrants that on the date of delivery to carrier the goods are free from defects in workmanship and materials.

SELLER'S SOLE OBLIGATION IN THE EVENT OF BREACH OF WARRANTY OR CONTRACT OR FOR NEGLIGENCE OR OTHERWISE WITH RESPECT TO GOODS SOLD SHALL BE EXCLUSIVELY LIMITED TO REPAIR OR REPLACEMENT, F.O.B. SELLER'S POINT OF SHIPMENT, OF ANY PARTS WHICH SELLER DETERMINES TO HAVE BEEN DEFECTIVE or if Seller determines that such repair or replacement is not feasible, to a refund of the purchase price upon return of the goods to Seller.

Any action against Seller for breach of warranty, negligence or otherwise, must be commenced within one year after such cause of action occurs.

NO CLAIM AGAINST SELLER FOR ANY DEFECT IN THE GOODS SHALL BE VALID OR ENFORCEABLE UNLESS BUYER'S WRITTEN NOTICE THEREOF IS RECEIVED BY SELLER WITHIN ONE YEAR FROM THE DATE OF SHIPMENT. Seller shall not be liable for any damage, injury or loss arising out of the use of the goods if, prior to such damage, injury or loss, such goods are (1) damaged or misused following Seller's delivery to carrier; (2) not maintained, inspected, or used in compliance with applicable law and Seller's written instructions and recommendations; or (3) installed, repaired, altered or modified without compliance with such law, instructions or recommendations.

UNDER NO CIRCUMSTANCES SHALL SELLER BE LIABLE FOR INCIDENTAL OR CONSEQUENTIAL DAMAGES AS THOSE TERMS ARE DEFINED IN SECTION 2-715 OF THE UNIFORM COMMERCIAL CODE.

INDEMNIFICATION AND SAFE OPERATION

Buyer shall comply with and require its employees to comply with directions set forth in instructions and manuals furnished by Seller and shall use and require its employees to follow such instructions and manuals and to use reasonable care in the use and maintenance of the goods. Buyer shall not remove or permit anyone to remove any warning or instruction signs on the goods. In the event of personal injury or damage to property or business arising from the use of the goods, Buyer shall within 48 hours thereafter give Seller written notice of such injury or damage. Buyer shall cooperate with Seller in investigating any such injury or damage and in the defense of any claims arising therefrom.

If Buyer fails to comply with this section or if any injury or damage is caused, in whole or in part, by Buyer's failure to comply with applicable federal or state safety requirements, Buyer shall indemnify and hold Seller harmless against any claims, loss or expense for injury or damage arising from the use of the goods.

CMCO Warranty (HOISTS)

- A. Columbus McKinnon Corporation ("Seller") warrants to the original end user ("Buyer") that: (a) for a period of one (1) year from the date of Seller's delivery of the goods (collectively, the "Goods") to the carrier, the electrical components of the Goods will be free from defects in workmanship and materials; and (b) for the life of the Goods, the mechanical components of the Goods will be free from defects in workmanship and materials.
- B. IN THE EVENT OF ANY BREACH OF SUCH WARRANTY, SELLER'S SOLE OBLIGATION SHALL BE EXCLUSIVELY LIMITED TO, AT THE OPTION OF SELLER, REPAIR OR REPLACEMENT, F.O.B. SELLER'S POINT OF SHIPMENT, OF ANY GOODS THAT SELLER DETERMINES TO HAVE BEEN DEFECTIVE OR, IF SELLER DETERMINES THAT SUCH REPAIR OR REPLACEMENT IS NOT FEASIBLE, TO A REFUND OF THE PURCHASE PRICE UPON RETURN OF THE GOODS TO SELLER. NO CLAIM AGAINST SELLER FOR ANY BREACH

OF (i) SUCH WARRANTY WITH RESPECT TO THE ELECTRICAL COMPONENTS OF ANY GOOD SHALL BE VALID OR ENFORCEABLE UNLESS BUYER'S WRITTEN NOTICE THEREOF IS RECEIVED BY SELLER WITHIN ONE (1) YEAR FROM THE DATE OF SELLER'S DELIVERY TO THE CARRIER AND (ii) SUCH WARRANTY WITH RESPECT TO THE MECHANICAL COMPONENTS OF ANY GOOD SHALL BE VALID OR ENFORCEABLE UNLESS BUYER'S WRITTEN NOTICE THEREOF IS RECEIVED BY SELLER WITHIN ONE (1) YEAR FROM THE DATE ANY ALLEGED CLAIM ACCRUES. EXCEPT FOR THE WARRANTY SET FORTH ABOVE, SELLER MAKES NO OTHER WARRANTIES WITH RESPECT TO THE GOODS, WHETHER EXPRESSED OR IMPLIED, INCLUDING ANY WARRANTIES OF MERCHANTABILITY, FITNESS FOR A PARTICULAR PURPOSE, QUALITY AND/OR THOSE ARISING BY STATUTE OR OTHERWISE BY LAW OR FROM ANY COURSE OF DEALING OR USE OF TRADE, ALL OF WHICH ARE HEREBY EXPRESSLY DISCLAIMED.

- C. IN NO EVENT SHALL SELLER BE LIABLE TO BUYER OR ANY THIRD PARTY WITH RESPECT TO ANY GOOD, WHETHER IN CONTRACT, TORT OR OTHER THEORY OF LAW, FOR LOSS OF PROFITS OR LOSS OF USE, OR FOR ANY INCIDENTAL, CONSEQUENTIAL, SPECIAL, DIRECT OR INDIRECT DAMAGES, HOWSOEVER CAUSED. SELLER'S MAXIMUM LIABILITY TO BUYER WITH RESPECT TO THE GOODS SHALL IN NO EVENT EXCEED THE PRICE PAID BY BUYER FOR THE GOODS THAT ARE THE SUBJECT OF THE APPLICABLE CLAIM.
- D. Seller shall not be liable for any damage, injury or loss arising out of the use of the Goods if, prior to such damage, injury or loss, such Goods are: (1) damaged or misused following Seller's delivery to the carrier; (2) not maintained, inspected, or used in compliance with applicable law and Seller's written instructions and recommendations; or (3) installed, repaired, altered or modified without compliance with such laws, instructions or recommendations.
- E. This warranty is limited and provided only to the original end user. Each Good must be registered within sixty (60) days of receipt of each product to establish eligibility. Please register at www.cmworks.com/hoist-warranty-registration or submit registration card via US mail.
- F. Any action against Seller for breach of warranty, negligence or otherwise in connection with the electrical components of any Good must be commenced by Buyer within one (1) year after: (a) the date any alleged claim accrues; or (b) the date of delivery of the Goods to Buyer, whichever is earlier. Any action against Seller for breach of warranty, negligence or otherwise in connection with the mechanical components of any Good must be commenced by Buyer within one year after the date any alleged claim accrues.



WARNING

Alterations or modifications of equipment and use of non-factory repair parts can lead to dangerous operation and injury.

TO AVOID INJURY:

- Do not alter or modify equipment.
- Do use only factory replacement parts.



COLUMBUS MCKINNON FAMILY OF BRANDS



MAGNETEK



USA: Ph: (800) 886.0985 • (716) 689.5400 • Fax: (716) 689.5644 • www.columbusmckinnon.com

CANADA: Ph: (877) 264.6478 • Fax: (877) 264.6477 • www.columbusmckinnon.com