

Operating, Maintenance & Parts Manual

JLC Series

MODEL NUMBERS

- JLC0232
- JLC0516
- JLC0532
- JLC1016
- JLC1032
- JLC2016
- JLC4008



For JLCET models refer to this manual and ETB680-1 for trolley information.

Follow all instructions and warnings for inspecting, maintaining and operating this hoist.

The use of any hoist presents some risk of personal injury or property damage. That risk is greatly increased if proper instructions and warnings are not followed. Before using this hoist, each operator should become thoroughly familiar with all warnings, instructions, and recommendations in this manual. Retain this manual for future reference and use.

Forward this manual to the hoist operator. Failure to operate the equipment as directed in the manual may cause injury.

Should you have any questions regarding this product, please call Coffing Hoists at (800) 477-5003.

Made in the U.S.A.

Before using the hoist, fill in the information below:

Model No. _____

Serial No. _____

Purchase Date _____

Please provide Serial Number when ordering parts.

COFFING® HOISTS

SAFETY PRECAUTIONS

Each Coffing JLC Series Electric Chain Hoist is built in accordance with the specifications contained herein and at the time of manufacture complies with our interpretation of applicable sections of *American Society of Mechanical Engineers Code (ASME) B30.16 "Overhead Hoists," the National Electrical Code (ANSI/NFPA 70) and the Occupational Safety and Health Act (OSHA). Since OSHA states the National Electrical Code applies to all electric hoists, installers are required to provide current overload protection and grounding on the branch circuit section in keeping with the code. Check each installation for compliance with the application, operation and maintenance sections of these articles.

*Copies of this standard can be obtained from ASME Order Department, 22 Law Drive, PO Box 2300, Fairfield, NJ 07007-2300, U.S.A., www.asme.org, 800-843-2763.

WARNING

Improper operation of a hoist can create a potentially hazardous situation which, if not avoided, could result in death or serious injury. To avoid such a potentially hazardous situation, THE OPERATOR SHALL:

1. **NOT** operate a damaged, malfunctioning or unusually performing hoist.
2. **NOT** operate the hoist until you have thoroughly read and understood the manufacturer's Operating and Maintenance Instructions or Manuals.
3. **NOT** operate a hoist which has been modified without the manufacturer's approval or without certification that it is in conformity with ANSI/ASME B30 volumes.
4. **NOT** lift more than rated load for the hoist.
5. **NOT** use hoist with twisted, kinked, damaged, or worn load chain.
6. **NOT** use the hoist to lift, support, or transport people.
7. **NOT** lift loads over people.
8. **NOT** operate a hoist unless all persons are and remain clear of the supported load.
9. **NOT** operate unless load is centered under hoist.
10. **NOT** attempt to lengthen the load chain or repair damaged load chain.
11. Protect the hoist's load chain from weld splatter or other damaging contaminants.
12. **NOT** operate hoist when it is restricted from forming a straight line from hook to hook in the direction of loading.
13. **NOT** use load chain as a sling, or wrap chain around load.
14. **NOT** apply the load to the tip of the hook or to the hook latch.
15. **NOT** apply load unless load chain is properly seated in the chain sprocket(s).
16. **NOT** apply load if bearing prevents equal loading on all load supporting chains.
17. **NOT** operate beyond the limits of the load chain travel.
18. **NOT** leave load supported by the hoist unattended unless specific precautions have been taken.

19. **NOT** allow the load chain or hook to be used as an electrical or welding ground.
20. **NOT** allow the load chain or hook to be touched by a live welding electrode.
21. **NOT** remove or obscure the warnings on the hoist.
22. **NOT** operate a hoist on which the safety placards or decals are missing or illegible.
23. **NOT** operate a hoist unless it has been securely attached to a suitable support.
24. **NOT** operate a hoist unless load slings or other approved single attachments are properly sized and seated in the hook saddle.
25. Take up slack carefully - make sure load is balanced and load holding action is secure before continuing.
26. Shut down a hoist that malfunctions or performs unusually and report such malfunction.
27. Make sure hoist limit switches function properly.
28. Warn personnel of an approaching load.

CAUTION

Improper operation of a hoist can create a potentially hazardous situation which, if not avoided, could result in minor or moderate injury. To avoid such a potentially hazardous situation, THE OPERATOR SHALL:

1. Maintain firm footing or be otherwise secured when operating the hoist.
2. Check brake function by tensioning the hoist prior to each lift operation.
3. Use hook latches. Latches are to retain slings, chains, etc. under slack conditions only.
4. Make sure the hook latches are closed and not supporting any parts of the load.
5. Make sure the load is free to move and will clear all obstructions.
6. Avoid swinging the load or hook.
7. Make sure hook travel is in the same direction as shown on the controls.
8. Inspect the hoist regularly, replace damaged or worn parts, and keep appropriate records of maintenance.
9. Use Coffing Hoists recommended parts when repairing the unit.
10. Lubricate load chain per hoist manufacturer's recommendations.
11. **NOT** use the hoist's overload limiting clutch to measure load.
12. **NOT** use limit switches as routine operating stops. They are emergency devices only.
13. **NOT** allow your attention to be diverted from operating the hoist.
14. **NOT** allow the hoist to be subjected to sharp contact with other hoists, structures, or objects through misuse.
15. **NOT** adjust or repair the hoist unless qualified to perform such adjustments or repairs.

TABLE OF CONTENTS

Safety Precautions	2
Hoist Specifications	3
Application Information	4
Installation	4
Operation	6
Maintenance	6
Troubleshooting	12
Wiring Diagrams	13
Inspection and Maintenance Check List	16
Recommended Lubrication Schedule	17
Replacement Parts List	18
Parts Depot and Warranty Repair Centers	32
Warranty	Back Cover

HOIST SPECIFICATIONS

Coffing JLC series electric chain hoists are rugged, portable hoists that provide quick, precise lifting. The hoists are constructed of tough, but lightweight, die cast aluminum alloy housings. An oil bath transmission, equipped with heat-treated, alloy steel gears and an overload limiting clutch, provides smooth and reliable operation. With a pushbutton station that fits comfortably in one hand, the operator can safely control the hoist while the other hand is free to guide the load. The electrical controls use a low voltage circuit (24V standard, 115V optional). Terminal blocks allow for easy voltage conversions on dual-voltage models.

Other features that ensure the safe operation of Coffing electric chain hoists include a magnetic disc brake that delivers sure stopping and secure holding of the load. Adjustable upper and lower limit switches regulate the load travel. As a standard, hooks are supplied with safety latches. For additional safety, a chain stop is attached to the slack end of the load chain.

Coffing electric chain hoists are designed and tested in accordance with the American Society of Mechanical Engineers Code B30.16, "Safety Standard for Overhead Hoists." Hoists are built in compliance with CSA, file number LR 44484. Made in U.S.A.

Table 1 - Hoist Specifications

Model	Hoist Capacity (lbs)	Lifting Speed (fpm)	HP	Reeving
JLC0232	250	32	1/4 / 1/2	Single-Chained
JLC0516	500	16	1/2	Single-Chained
JLC0532	500	32	1/2	Single-Chained
JLC1016	1000	16	1/2	Single-Chained
JLC1032	1000	32	1	Single-Chained
JLC2016	2000	16	1	Single-Chained
JLC4008	4000	8	1	Double-Chained

* **Note:** JLCET models are equivalent to the corresponding JLC, but are supplied with a push-type trolley. Reference in this manual to JLC models also applies to JLCET models.

Table 2 - Motor Amperage of 1-Speed Hoist Models

Hoist HP	Full Load Amps (fast/slow)			
	1-Phase 115/230V	208V	3-Phase 230/460V	575V
1/4	N/A	1.9	1.7/1.85	.7
1/2	8.4/4.2	2.3	2.1/1.05	.7
1	14.8/7.4*	4.6	3.9/1.95	1.6

*The 1HP, 115/230V models (JLC1032-1, JLC2016-1, JLC4008-1) must have a dedicated power circuit rated for at least 20A, 125V when they are wired for 115V. It is not unusual for these models to draw up to 20 amps at 115V when lifting at rated capacity depending on the quality of the voltage source.

Table 3 - Motor Amperage of 2-Speed Hoist Models

Hoist HP (fast/slow)	Full Load Amps for 3 Phase Only (fast/slow)			
	208V	230V	460V	575V
.25 / .083	2.0/1.9	2.2/2.2	.9 / .9	.64 / .71
.5 / .17	3.8/3.2	3.7/3.0	1.35/1.25	1.15/1.05
1 / .33	4.6/5.8	5.0/3.5	2.25/1.55	2.1/1.4

NOTE: The above data is the nominal motor current at full load. At full load, it is not unusual for the hoist to draw in excess of the values listed when lifting. It is critical to ensure that the voltage at the reversing contactor does not drop more than 10% below the nominal voltage while lifting a load. Low voltage will result in higher amp draw, damage to the hoist, and potential fire hazards. Coffing Hoists is not responsible for any damages caused by an inadequate power source.

WARNING

Failure to comply with Safety Precautions outlined throughout this manual can result in serious injuries or death. Before using this hoist, each operator should become thoroughly familiar with all warnings, instructions and recommendations in this manual.

APPLICATION INFORMATION

This hoist is intended for general industrial use for lifting and transporting freely suspended material loads within its rated capacity. Coffing Hoists cannot be responsible for applications other than those for which Coffing equipment is recommended. Prior to installation and operation, we caution the user to review his application for abnormal environmental or handling conditions and to observe the applicable recommendations as follows:

ADVERSE ENVIRONMENTAL CONDITIONS

Do not use the hoist in areas containing flammable vapors, liquids, gases or any combustible dusts or fibers. Refer to Article 500 of the National Electrical Code. Do not use this hoist in highly corrosive, abrasive or wet environments. Do not use this hoist in applications involving extended exposure to ambient temperatures below -10°F or above 130°F.

LIFTING OF HAZARDOUS LOADS

This hoist is not recommended for use in lifting or transporting hazardous loads or materials which could cause widespread damage if dropped. The lifting of loads which could explode or create chemical or radioactive contamination if dropped requires fail-safe redundant supporting devices which are not incorporated into this hoist.

LIFTING OF GUIDED LOADS

This hoist is not recommended for use in the lifting of guided loads, including dumbwaiters and elevators. Such applications require additional protective devices which are not incorporated into this hoist. For such applications, refer to the requirements of applicable state and local codes, and the American National Safety Code for elevators, dumbwaiters, escalators and moving walks (ASME A17.1).

SAFETY INFORMATION

1. Follow all local electrical and safety codes, as well as the National Electrical Code (NEC) and the Occupational Safety and Health Act (OSHA) in the United States.
2. Hoist must be securely and adequately grounded. Hoist power cable is provided with an additional lead (green) for grounding purposes.

WARNING

Always disconnect power source before working on or near a hoist or its connected load. If the power disconnect point is out of sight, lock it in the open position and tag to prevent unexpected application of power.

3. Be careful when touching the exterior of an operating motor; it may be hot enough to be painful or cause injury. With modern motors this condition is normal if operated at rated load and voltage (modern motors are built to operate at higher temperatures).
4. Protect the power cable and control cable from coming in contact with sharp objects.
5. Do not kink power cable and control cable and never allow the cable to come in contact with oil, grease, hot surfaces, or chemicals.

6. Make certain that the power source conforms to the requirements of your equipment.
7. Inspect the unit daily before operating the hoist.
8. Cluttered areas and benches invite accidents.
9. The operator should not engage in any practice which will divert his attention while operating the hoist.
10. Before using the hoist, the operator should be certain that all personnel are clear.
11. Do not operate hoist with loads exceeding its rated capacity.
12. Supporting frames or beams used as a hoist hanger must have a greater load capacity than the hoist.
13. Do not attempt to operate the hoist beyond normal maximum lift range.
14. Align hoist for a straight line pull. Avoid side pull or end pull.
15. Do not operate hoist with twisted or damaged chain.
16. Do not operate a damaged or malfunctioning hoist until necessary adjustments or repairs have been made.
17. Do not use hoist to lift people or to carry loads over people.
18. Do not leave a load suspended in the air unattended.
19. Always remove load before making repairs.
20. Do not remove or obscure capacity or warning decals.

INSTALLATION

1. Before installing the hoist, check the following:
 - a. Make sure all supporting structures and attaching devices are strong enough to hold your intended loads. If in doubt, consult a qualified structural engineer.
 - b. Provide proper branch circuit protection for the hoist as recommended in the National Electrical Code.
 - c. The power supply should be plus or minus 10% of the voltage specified on the motor nameplate. It is critical to use adequate sized power cables, especially with 1-phase hoists (**See Table 5, page 11**). Be sure dual voltage hoists are connected or wired to correspond with your power supply (See WIRING, page 9).
 - d. Installation area must provide operating conditions for the operator including sufficient room for the operator and other personnel to stand clear of the load at all times.
 - e. For installations where the slack chain hanging from the unit may be objectionable or hazardous, the use of a chain container is recommended (See CHAIN CONTAINER, page 5).
2. JLCET models come with a Coffing ETB push-type trolley and an adaptable suspension lug. ETB trolleys are made to run on American Standard I-Beams and Wide Flange Beams with flange widths up to 8". For assembly refer to the instructions provided with the trolley. The hoist lug must be centered with the sideplates (± 1 washer). Due to the lug thickness, the washer placement between each sideplate and the lug may differ by 1 less washer than the generic instructions specify. For installations where the trolley can not be slid onto the end of a beam, leave the load pin nuts loose enough to get the wheels around the beam flange. Check the flange width setting before tightening the nuts to **125 ft-lbs**. Be sure to have end stops on your beam.
3. Before operating the hoist, be sure to observe the following:
 - a. ALWAYS DISCONNECT HOIST FROM POWER SUPPLY before removing electrical cover or when making any electrical connection in the hoist or pushbutton station.
 - b. The ground wire (green colored) of the power cable

should always be connected to a suitable ground by means of a screw or clamp. An alligator clip does not make a safe ground connection.

- c. When installing a three-phase hoist, make only temporary connections at the power source. Push the “UP” button and observe the direction of the load block. If it raises, the phasing is correct and permanent connections may be made at the power source. If the load block lowers when the “UP” button is pushed, release the button immediately since the limit switches will not operate to protect the hoist from over-travel. Reverse any two wires (except the green ground wire) at the power source to correct the load hook direction (phasing). Do not change connections in the hoist or pushbutton assembly.
 - d. Make sure load chain is not twisted as it travels into the hoist.
 - e. Operate hoist in a hanging position only. Hoist should be permitted to align itself for a straight line pull. Do not attempt to pull around corners.
 - f. Read ASME-B30.16 Safety Code for Hoists.
4. Lubricate the chain if necessary, see LUBRICATION, page 9.
5. Check the function of the limit switches. Before placing hoist in operation, check limit switch settings. Operate pushbutton until near stop point and inch into stop limit, both top and bottom. If either switch is not correct, adjust according to LIMIT SWITCH ADJUSTMENT, page 8.

CHAIN CONTAINER (Optional Accessory)

Refer to Table 4.

For installations where the slack chain hanging from the hoist may be objectionable or hazardous, the use of a chain container is recommended.

Available chain containers include the standard containers designed for lifts of up to 50 ft on single-chained hoists and 25 ft on double-chained hoists. For longer lifts, the JLC927-4 container is available. For applications where a fabric bag is preferred, the JLC927-20F, JLC927-35F and the JLC927-50F are all options.

⚠ CAUTION

Do not attempt to store more chain in chain container than that specified in the table below or serious damage to hoist may result and hazardous conditions may be created.

Instructions are provided with each of these chain containers and must be adhered to closely to ensure a proper installation. To install the long lift chain container or a fabric chain container, you must follow instruction sheets provided with the chain container. The following instructions are for the standard metal chain containers only.

Installation of Standard Chain Containers (JLC927-1)

Refer to Figure 1.

1. Remove retaining clip and attachment pin and let the slack chain hang free.
2. Run load hook down to its lowest position. Place the slack end of chain in chain container. Do not remove the chain stop.
3. Place chain container flush against housing with chain stripper between top lugs. Insert long attachment pin and replace retaining clip.
4. Feed the remainder of chain into container by operating hoist in the “UP” direction to the top limit. This will permit the chain to pile freely and prevent the chain from kinking, which may occur if the chain is placed in the container by hand.

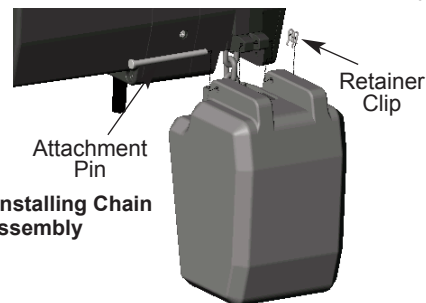

Figure 1 — Installing Chain Container Assembly

Table 4 - Optional Chain Containers

Chain Container Model	Recommended for Use With: Hoist Capacity	Maximum Lift (ft)	Container Material	Dimensions in Inches		
				Width	Length	Depth
JLC927-1	1 Ton & Under 2 Ton	20 10	Molded Container	6 7/8"	6 1/2"	10 3/8"
JLC927-2	1 Ton & Under 2 Ton	35 17	Molded Container	6 1/2"	6 1/2"	15 3/4"
JLC927-3	1 Ton & Under 2 Ton	50 25	Molded Container	6 1/2"	6 1/2"	20 1/4"
JLC927-4	1 Ton & Under 2 Ton	143 71	Steel or Molded Container	*	*	*
JLC927-20F	1 Ton & Under 2 Ton	20 10	Open Weave Vinyl Coated Polyester	7 1/2"	7 1/2"	16"
JLC927-35F	1 Ton & Under 2 Ton	35 17	Open Weave Vinyl Coated Polyester	7 1/2"	7 1/2"	22
JLC927-50F	1 Ton & Under 2 Ton	50 25	Open Weave Vinyl Coated Polyester	7 1/2"	7 1/2"	26
JLC927-70F	1 Ton & Under 2 Ton	70 35	Open Weave Vinyl Coated Polyester	7 1/2"	7 1/2"	31

* Dimensions depend on length of lift. Contact Factory.

OPERATION

This hoist is designed for safe operation within the limits of its rated capacity. It is controlled by the "UP" and "DOWN" buttons of the pushbutton station. Two-speed models utilize 2-step buttons, the first step for operating the slow speed and the second for the fast speed. Although the Coffing JLC is built with many features to ensure safety, it is a requirement that a hoist operator understands safe lifting practices. The following points must be observed.

CAUTION

Do not allow load to come in contact with the chain container. If this situation exists reset the "UP" limit switch so that the hook block stops below the chain container (See LIMIT SWITCH ADJUSTMENT, page 8).

1. Do not overload the hoist.
2. Do not make extreme side pulls with the hoist.
3. Operate the hoist only in a hanging position with adequate support.
4. Do not "sling" the load hook and chain around the load. Use an approved sling.
5. **Be sure there are no twists in the load chain** as it travels into the hoist housing. This condition should be constantly checked on double chain hoists because it is possible for the load block to be "capsized" or turned over one or more times.
6. Before raising a load, always check to see that it is held securely in the hook or sling chains, etc. Raise the load only until the load chain is taut and then double check the rigging before continuing to raise the load.
7. Do not stand beneath a load! Do not move a load in such a manner as to endanger personnel.

WARNING

Do not use hoist to lift, support or otherwise transport people.

8. Don't lower into areas where visibility is obscured unless someone else is guiding the operation.
9. Use common sense at all times when operating a hoist.
10. Do not operate if direction of hook travel is not the same as indicated on button being pushed.
11. Do not operate unless hook travel limit devices function. Test without load each shift.
12. Do not operate when hoist is not centered over load.
13. Do not operate if chain is not seated properly in sprockets or sheave grooves.
14. Do not operate damaged or malfunctioning hoist.

OVERLOAD LIMITING PROTECTION

This hoist is equipped with a factory-calibrated overload limiting clutch that will permit the lifting of loads within its rated capacity, but will prevent the lifting of damaging overloads while the hoist is being operated. If the load being lifted exceeds the lifting capability of the overload clutch, the hoist motor will continue to run, causing overheating of both the clutch and hoist motor. This condition should be avoided by immediately releasing the "UP" button and reducing the load to within the rated capacity of the hoist. See GEARING, page 10, for additional instructions on this device.

MAINTENANCE

INSPECTIONS

A planned inspection routine should be established for this hoist based upon frequency of use, severity of use, and environmental conditions (Reference ASME Standard B30.16). Some inspections should be made frequently (daily to monthly) and others periodically (monthly to yearly). It is strongly recommended that an Inspection and Maintenance Check List and an Inspector's Report, similar to those shown in Figures 10A and 10B, be used and filed for reference. All inspections should be performed or overseen by a designated inspector. Special inspections should be made following any significant repairs or any operating occurrence leading one to suspect that the hoist's capability may have been impaired.

CAUTION

The overload limiting clutch is an emergency protective device and should not be used to measure the maximum load to be lifted, or to sense the overload imposed by a constrained load. While the overload limiting clutch will protect the hoist from damaging overloads, it will not ensure that a load is within the rated capacity of the hoist.

LOWERING WITHOUT POWER

If the power fails with a load suspended, the hoist will automatically stop. In an emergency the load can be lowered without power as follows:

1. DISCONNECT HOIST FROM POWER SUPPLY AND REMOVE ELECTRICAL COVER.
2. Refer to Figure 5. Open disc brake manually by using two screwdriver blades, one on each side of the brake at a point close to the brake spring posts. Apply pressure to the underside of the armature plate (points "X") to close the solenoid and release the brake.
3. Use several quick releases instead of holding brake open continuously. Do not exceed normal lowering speed.

WARNING

Do not allow screwdriver blades to touch rotating friction disc "C".

CAUTION

Do not allow the load to descend rapidly. This causes the motor to race and serious damage may result.

HOOKS

Refer to Figure 2.

1. Inspect hooks once daily for cracking, extreme wear or spreading. Replace hooks showing any of these signs. If the throat openings are spread wider than the maximum permissible 15% increase listed here, the hooks have been overstressed and must be replaced. Any hook that is bent or twisted more than 10 degrees from the plane of an unbent hook must also be replaced.

2. The hook latches should be inspected to ensure that they close the hook throat opening in a secure manner when a load is applied. Inspect the hook shank and nut for any stripping of the threads or other damage. The hook nut should be fully restrained by the retaining pin.
3. In addition to above, load hooks should be inspected for cracks by the magnetic particle, dye penetrant or other suitable crack testing inspection method. This should be done at least once a year.

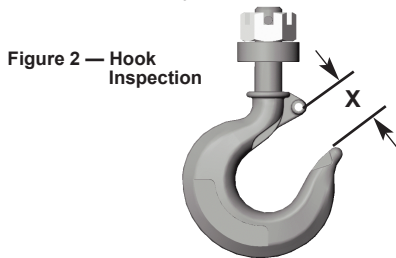

Hoist Capacity	"X" Dimension*	
	Top Hook	Bottom Hook
1 Ton & Under	1 1/32"	1 7/32"
2 Ton	1 1/32"	1 11/32"

(*) Maximum permissible throat opening of hook.

CHAIN

Chain inspection and lubrication are the most important aspects of hoist maintenance. Chain is to be kept clean and lubricated (See LUBRICATION, page 9) at all times. Visually check the chain every time the hoist is used. Hoist must not be operated when the chain is twisted or kinked. Chain inspection will not usually require removal of the chain from the hoist, but the chain should be run through the hoist enough so that every link is made visible for inspection.

- a. Check each link for gouges, nicks, weld splatter, corrosion, and distortion.
- b. Inspect each link for wear to the diameter of the link.

The nominal link diameter is 0.281 inch. If the diameter of any link of 0.281 chain is worn to less than 0.225 inch, the entire chain must be replaced.

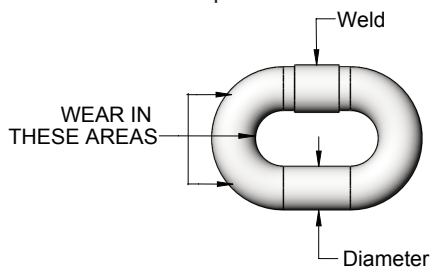

- c. 1.) Check the chain for overall wear or stretch by selecting an unworn, unstretched length of chain (at the slack end, for example). Let the chain hang vertically with a light load (about 20 pounds) on the chain to pull it taut. Use a large caliper to measure the outside length of a convenient number of links (about 12 inches). Measure the same number of links in a used section of chain and calculate the percentage increase in length of the worn chain.
- 2.) If the length of the worn chain is more than 1 1/2% longer than the unused chain (0.015 inch per inch of chain measured), then the chain should be replaced. If the chain is worn less than 1 1/2%, check it at several more

- places along its length. If any section is worn more than 1 1/2%, the chain should be replaced.
- d. The chain used in the hoist is accurately calibrated to operate over the load sprocket and is very carefully heat treated for maximum wear life and strength.

WARNING

Do not weld or join hoist load chain. Do not substitute another manufacturer's chain in this hoist. Damage or wear, beyond the stated limits, to any portion of the chain requires that the entire length of chain be replaced.

Chain Replacement with Chain in Hoist

Refer to Figures 3 & 4.

1. Run hook up to its top limit.
2. DISCONNECT HOIST FROM POWER SUPPLY and remove the electrical cover.
3. Using a screwdriver, pry the spring guide plate out of the slots in the limit switch nuts (See Figure 3). Turn the gold nut back to about the center of the threaded screw. Do not disconnect the wires from the limit switches.
4. Remove the load block assembly from the old chain. On double-chained hoists detach the chain from the chain support and pull it through the load block assembly (See Figure 4).
5. Make a "C" shaped chain link by grinding through the end link on the load end of the old chain.
6. Using the "C" link, attach the new chain to the load end of the old chain. Be sure that the welds of the upstanding links of the new chain will face outward from the load sheave. The end links must be oriented for attachment to the dead-end attachment pin and the chain support (double-chained only) without any twist in the chain. (See Figure 23)
7. With the electrical cover off, connect the hoist to the power supply. Be sure that the green ground wire is properly grounded (See INSTALLATION 3b, page 4).
8. Carefully jog the "UP" button and run the joined pieces of chain into the hoist until about 15" of the new chain comes out the other side.
9. DISCONNECT HOIST FROM POWER SUPPLY.
10. Remove the "C" link and the old chain. Remove the chain stop by prying off its retaining ring with a flathead screwdriver. If attached, remove the old chain from the chain stripper by removing the retainer clip and attachment pin.
11. Attach the chain stop to the slack end of the new chain by capturing the 12th link with the two stop halves positioned with their tapered ends pointing towards the hoist. Slide the sleeve over the halves and attach the retaining ring. If you are not using a chain container, attach the slack end of the new chain to the side of the hoist using the attachment pin and retainer clip. DO NOT allow twists in the chain.
12. Adjust the lower limit switch (See ADJUSTING LOWER LIMIT, page 8).
13. Attach the bottom block on single-chained hoists using a new load block pin (See Figure 23). On double-chained hoists, feed the chain through the load block (welds of the upstanding links will be in towards the sheave) and fasten the end of the chain to the chain support using a new chain support pin (See Figure 23). **Be sure there are no twists in the chain.**
14. Adjust the upper limit switch (See ADJUSTING UPPER LIMIT, page 8).

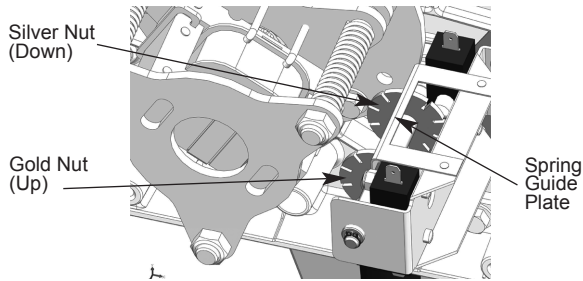

Figure 3 — Limit Switch Assembly

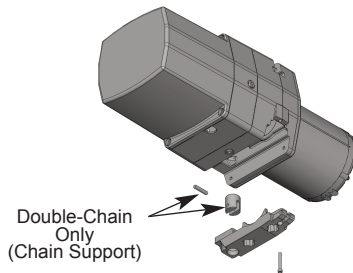

Figure 4 — Chain Replacement Diagram

Chain Replacement with No Chain in Hoist

Refer to Figure 4.

1. DISCONNECT HOIST FROM POWER SUPPLY and move hoist to a work table. Remove the electrical cover, electrical panel and the electric brake assembly.
2. Detach the chain stripper from the bottom of the hoist.
3. Insert the new chain between the load sheave and the chain guide. Feed the chain into the hoist by manually turning the brake hub adaptor. Allow about 15" of chain below the hoist on the slack end. Be sure the welds of the upstanding links are out away from the load sheave and that proper orientation is observed for attachment of the slack end. Also be sure the load hook assembly (if already attached to the chain) is toward the center of the hoist or to your right looking from the motor end.
4. Reinstall the chain stripper (with the chain support on double-chained hoists, See Figure 4) observing proper chain alignment and avoiding any twist in the chain.
5. Follow steps 11 through 14 in previous section, CHAIN REPLACEMENT WITH CHAIN IN HOIST, to complete the chain replacement procedure.
NOTE: Inspect chain guide and load sheave for wear, replace as needed.

LIMIT SWITCH ADJUSTMENT

IMPORTANT: Before placing hoist in operation, check the limit switch adjustment. Limit switches are provided to protect the hoist against damage resulting from overtravel or to allow setting the hook travel within the factory-set limits of travel. The standard limit switch is designed for lifts of 50 ft or less on single-chained hoists and 25 ft or less on the 2 ton, double-chained models. The long lift limit switch allows for the maximum amount of lift, which is 143 ft on the 1 ton and under models, and 71 ft on the 2 ton models.

The upper and lower limit switch adjusting nuts are color-coded gold and silver respectively. Each limit nut has 10 slots for fine adjustment, and the increment of adjustment is such that one slot is equivalent to approximately one link of chain

travel with the standard limit switch. Movement of the limit switch nuts toward or away from each other increases or decreases the hook travel respectively.

Adjusting Upper Limit (Gold Nut)

Refer to Figure 3.

1. Suspend the hoist. For single chain models raise the load block until there is a minimum clearance of 2" from the hoist housing and the top of the block. Double chain models require a minimum clearance of 1" from the chain support to the top of the load block.
2. DISCONNECT HOIST FROM POWER SUPPLY and remove the electrical cover.
3. With a screwdriver, pry the spring guide plate out of the slots in the limit switch nuts.
4. Turn the slotted gold nut toward its limit switch until the switch "clicks" then turn two slots farther. Release the spring guide plate and be sure it slips back into the slots in both limit switch nuts. Do not disturb the silver slotted nut if it has been set previously.

Adjusting Lower Limit (Silver Nut)

Refer to Figure 3.

1. Suspend the hoist. Carefully lower the load block to a point where the slack-end loop of the chain hangs down 6" or more from the hoist housing (or the limit desired in any particular application allowing the minimum 6"). There should be a minimum clearance of 1½" between the chain stop and bottom of hoist.
2. DISCONNECT HOIST FROM POWER SUPPLY and remove the electrical cover.
3. With a screwdriver, pry the spring guide plate out of the slots in the limit switch nuts.
4. Turn the slotted silver nut toward its limit switch until the switch "clicks," then turn two slots farther. Release the spring guide plate and be sure it slips back in the slots in both limit switch nuts. Do not disturb the gold slotted nut if it has been set previously.

Check Both Upper and Lower Limits

1. Connect the hoist to the power supply. Be sure the green ground wire is properly grounded (See Installation 3-b, page 4).
2. Check load hook direction (See Installation 3-c, page 5).
3. Carefully raise load block to upper limit and observe if it stops automatically at desired level. Do not allow load block to run into hoist housing — this will damage the hoist. Maintain a minimum clearance of 2" from the hoist housing and the top of the load block on single-chained models and 1" from the chain support to the top of the load block on double-chained models.
4. Carefully lower load block to lower limit and observe if it stops automatically at the desired level. Do not allow slack-end loop of chain to become taut against hoist housing. This will damage the hoist. There should be a minimum clearance of 1½" between the chain stop and the bottom of the hoist.
5. If upper and lower limits operate satisfactorily, hoist is ready for use. If they are not as desired, repeat adjustment.

⚠ CAUTION

If the wires running to the limit switches are ever disconnected for any purpose, be sure to replace wires in accordance with the correct wiring diagram (See Figures 9A, 9B, 9C & 9D).

BRAKE

Properly adjusted, this brake will release promptly when energized. It is capable of both smoothly stopping and securely holding the rated capacity of the hoist. If the hoist develops either undesirable over-travel after the pushbutton is released (this condition is most noticeable in the lowering direction) or hesitates to lift the load promptly when the pushbutton is depressed (this condition is most noticeable in the hoisting direction), the brake should be adjusted.

Brake Adjustment

Refer to Figure 5.

1. DISCONNECT HOIST FROM POWER SUPPLY and remove the electrical cover.
2. With reference to Figure 5, the gap between the brake armature "A" and the field "B" should be checked. The correct gap is 0.015". Adjustment should not be necessary until gap reaches 0.040".
3. Adjust the gap using a 9/16" socket on the 3 locknuts "F". Check with a feeler gauge to be sure the gap is the same on both ends of the solenoid.
4. Adjustment is now complete and the brake properly set. Replace the electrical cover, reconnect the power supply, and check hoist brake action.

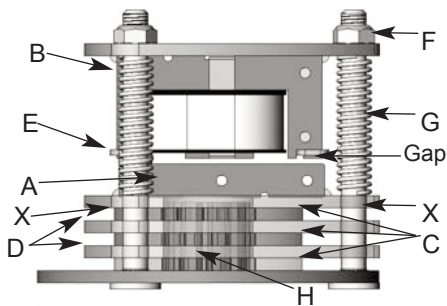

Figure 5 — Brake Assembly

CAUTION

Be sure the bottom of the armature does not bear against the splined adapter "H". As adjustments are made, the built-in clearance will be reduced. When this clearance is gone REPLACE BRAKE DISCS. Minimum allowable disc thickness is .162".

HOIST CONTROLS

Both the pushbutton and the reversing contactor are mechanically interlocked to prevent shorting the circuit and causing serious damage. As part of maintenance, always check for proper closure of contact points as well as for burned contacts. If replacement is necessary, see Figures 16, 17, 18, and 19 for replacement parts.

WIRING

Refer to Figures 9A, 9B, 9C & 9D.

Single-phase units (115/230V) are shipped wired for 115V and the 1-speed, 230/460V-3 phase units are wired for 460V unless otherwise specified when ordered. Hoists wired for other voltages and 2-speed units are single voltage only. Conversion of dual-voltage hoists to either the higher or lower voltage can be done simply and quickly as follows:

1. DISCONNECT HOIST FROM POWER SUPPLY and remove the electrical cover.
2. Each dual-voltage hoist has a terminal block assembly for the interconnection of the electrical components of the hoist. To convert the voltage, reconnect the leads to the terminal blocks according to the wiring diagram located inside the electrical cover or Figures 9A, 9B, 9C and 9D. **DO NOT move any wires or make any changes to the electrical circuit except at the terminal block assembly. Tug on wires to ensure they are securely connected.**
3. After converting the voltage, recheck phasing and limit switch operation (See INSTALLATION 3-c & 5, page 5).

IMPORTANT: Always refer to the wiring diagram located on the inside of the electrical cover or Figures 9A, 9B, 9C and 9D when performing electrical repairs. Make sure all connections are secure and check for damaged insulation. It is also imperative that the power circuit has conductors of adequate size (See Table 5).

LUBRICATION

Refer to Figure 11.

Proper lubrication is necessary for a long and relatively trouble-free hoist operation. Refer to the following and the RECOMMENDED LUBRICATION SCHEDULE for lubrication points, type of lubricant, and frequency of lubrication.

Load Chain

Clean the load chain with acid-free solvent and coat with SAE 90 gear oil. Wipe excess oil to prevent dripping. Never apply grease to the chain.

Gearing

The gear case of this hoist is filled at assembly with approximately 2 pints of SAE 90 EP gear oil. Check oil level by removing the oil level fill plug from the side of the hoist. With the hoist hanging level, gear oil should be even with the hole. Change oil periodically depending on the severity of the application and the environmental conditions (at least every 200 hours of run time).

Bearings

All bearings except hook and idler sheave bearings are lubricated at the factory and should not require additional lubrication. Noisy or worn bearings should be replaced.

Limit Switch Shaft

Remove any dirt accumulation and spray with a general purpose lubricant.

Hook Bearing

Apply a few drops of SAE 30 gear or motor oil around the edge of the bearing.

Idler Sheave Bearing (Bushing)

Disassemble load block and apply a light coat of NLGI #2 grease, or equivalent, inside of bearing.

HOIST REPAIRS

1. For major repairs or when the hoist is to be sectioned in the suspension area, it will be necessary to move the hoist to a workbench or table.
2. For repairs which can be done by removing the electrical cover only, the hoist need not be moved. Lowering the hoist to a convenient working level is desirable.

NOTE: If you do not have an experienced mechanic to do your repair work, we recommend that you send your hoist to an approved service station for repairs. Use authorized repair parts only.

⚠ WARNING

Remove load and disconnect hoist from power supply before starting to do any repairs or to take any sections apart.

The following repair instructions will help you in understanding repair procedures, when related to the Replacement Parts List starting on page 18. For clarity these are broken down into areas.

Electrical Parts and Brake

1. Refer to Figures 15, 16 and 17. Remove the cover to access the controls. Single-phase models also have a starting switch and capacitor mounted on the panel as shown in Figure 16. The terminal blocks and end clamps snap off of the rails on the plate using a small screwdriver. **DO NOT SLIDE THE END CLAMPS.** The reversing contactor can be slid off the rail, but it must be snapped on. Where the contactor fits the rail, one side has springs or pads that apply pressure against the edge of the rail. By pressing against that side at the base of the contactor, you can snap the part on or off using a rotating action. Note the numbers that label the terminals on the contactor and orient the part as shown in Figures 9A-9D. Single-phase contactors have a small jumper that is not present on the 3-phase (note the 3 and 5 terminals on the reversing contactor in Figure 9A).
2. Remove the electrical panel by removing the stand-off screws (See Figures 16 & 17). The limit switch and brake are now accessible as shown in Figure 6.

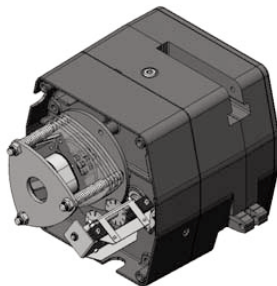

Figure 6 - Electrical Panel Removed

3. Remove the transformer bolted to the back of the panel plate if it requires replacement.
4. Refer to Figure 15 to disassemble the brake. See BRAKE ADJUSTMENT on page 9 to properly set the brake.
5. Refer to Figures 20 and 21 to disassemble the limit switch. See LIMIT SWITCH ADJUSTMENT on page 8 to properly set the upper and lower limits of travel.
6. Refer to Figures 18 and 19 for repairs on the pushbutton station. Also refer to the wiring diagram inside the electrical cover or Figures 9A, 9B, 9C and 9D for wiring instructions.

Motor

Refer to Figures 12, 13 and 14.

The hoist motor is located on the opposite end from the electrical parts, but the two are tied together with electrical leads running through the housing.

1. If it is necessary to replace or repair the motor, **DISCONNECT THE HOIST FROM THE POWER SUPPLY** and remove the electrical cover.
2. Loosen the screw clamps on the terminal blocks and reversing contactor to disconnect the motor leads (See Figures 16 and 17).
3. Remove the four motor mounting bolts attaching the motor to the housing. It will come loose at the motor coupling.
4. Inspect the motor coupling, motor shaft and all the bearings. Replace as necessary.
5. Install new or repaired motor according to the wiring diagram located inside the electrical cover or Figures 9A, 9B, 9C and 9D.

Gearing

Refer to Figures 7, 12 and 22.

As disassembly is extensive for gearing, disconnect the hoist and move it to a workbench.

1. Remove the electrical cover.
2. Remove the electrical panel.
3. Remove the brake assembly and the limit switch assembly.
4. Drain the oil from the transmission.

⚠ CAUTION

There are wires running through the hoist. Carefully ease the hoist sections apart. Do not jerk them apart.

5. Remove the five screws that attach the transmission cover to the transmission housing and remove the transmission cover. The limit switch drive shaft will come along with the cover.

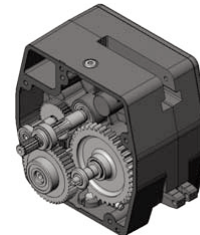

Figure 7 - Assembled Gearing

6. Inspect gears for broken or severely worn teeth and inspect all bearings. Replace as necessary. The overload slip clutch is factory calibrated and must not be disassembled or readjusted.

⚠ CAUTION

Do not disassemble or readjust the clutch, or replace it with a clutch assembly from another hoist. Doing so will void the warranty and may create an unsafe condition. If replacement is needed due to wear or loss of adjustment, always use a new clutch assembly.

7. Reassemble in reverse order of disassembly, making sure that the gasket is in place and in good condition. Coat gasket with Permatex® or other gasket cement. Extreme care should be taken to avoid damage to oil seals.
8. Check all wire terminals to be sure that they are properly seated and in accordance with the correct wiring diagram. Before placing the hoist back into service, check the brake adjustment and limit switch settings.

CHAIN GUIDE and LOAD SHEAVE (Refer to Figures 12, 22 & 23)
The hoist sections must be separated at the top hook line in order to inspect the Load Sheave and Chain Guide.

1. Disconnect the Hoist and remove to a workbench.
2. Remove the Socket Head Cap Screw and Attachment Pin that hold in the Chain Stripper.
3. Remove the Chain Stripper.
4. Remove the 4 bolts that hold on the Motor.
5. Remove the Motor.
6. Remove the Spring Washer and Motor Coupling.
7. Remove the Hook Retaining Screw.
8. Remove the Hook Retainer.
9. Remove the Top Hook (Note the orientation of the hook for reassembly).
10. Remove the remaining 3 Screws that hold on the Trim Cover.
11. Remove the Trim Cover.
12. Remove the 5 Socket Head Cap Screws that hold the Sheave Housing to the Transmission Housing.
13. Gently pry apart the two housings using the slots provided, taking care not to damage the Gasket between the two housings.

While these housings are apart, check the following:

- Chain Stripper
- Chain Guide
- Chain
- Load Sheave
- Load Sheave Shaft
- Bearings
- Chain Support (on 2 ton models)

Replace worn or damaged parts as necessary including screws, lock washers, pins, etc.

Care must be taken during reassembly to have the hook in the proper orientation (See SUSPENSION, page 11).

SUSPENSION (Refer to Figures 8A, 8B & 8C)

Periodic inspections of the top suspensions can be made without disassembly. For more extensive inspections the lug or top hook may be removed as follows:

1. Disconnect the Hoist and remove it to a workbench.
2. Remove the Hook Retaining Screw.
3. Remove the Hook Retainer.
4. Remove the Hook (Note the orientation of the hook for reassembly).

Care must be taken during reassembly to have the hook in proper orientation. Refer to figures 8A, 8B & 8C for proper orientation.

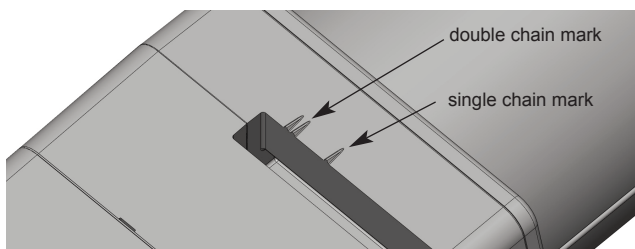

Figure 8A - Hook Orientation Marks

For Single Chain Hoist Installations, orient the centerline of the top hook with the single mark on the top of the sheave housing (Figure 8A). Hook installation should be as shown in Figure 8B.

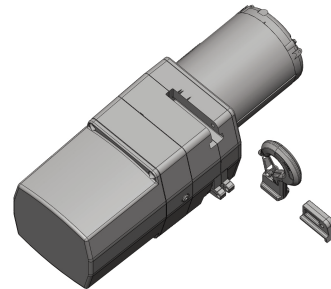

Figure 8B - Single Chain Hook Orientation

For Double Chain Hoist Installations, orient the centerline of the top hook with the double marks on the top of the sheave housing (Figure 8A). Hook installation should be as shown in Figure 8C.

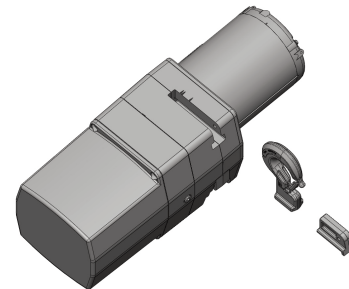

Figure 8C - Double Chain Hook Orientation

When reassembled, recheck the limit switch settings (See LIMIT SWITCH ADJUSTMENT, page 8)

POWER CORD PRECAUTIONS WITH 1-PHASE HOISTS

Electric hoists require a sufficient power supply. It is especially important with single-phase voltage to ensure that the conductors running to the hoist from the power source are adequate in size to handle the power requirements of the hoist. Inadequate **power cables** and **branch circuits** will cause low voltage, high amperage, damage to the hoist, and potential fire hazards. Such problems can be minimized by using 230V power on 115/230V hoists. The following are recommendations for the conductor gage size depending on the length, horsepower, and voltage.

Table 5 - Recommended Conductor Sizes for 1-Phase Hoists

HP	Voltage (1-Phase)	Maximum Length of Power Cord in Feet			
		14 AWG	12 AWG	10 AWG	8 AWG
1/4	115V	75	120	190	300
	230V	350	560	900	-
1/2	115V	40	60	100	150
	230V	200	330	520	810
1	115V	0	30	50	75
	230V	120	190	310	490

TROUBLESHOOTING

Always disconnect unit from the power supply system before removing hoist covers or the back cover of control station.



WARNING

Failure to follow proper lockout/tagout procedures may present the danger of electrical shock.

TO AVOID INJURY:

Disconnect power and lockout/tagout disconnecting means before removing cover or servicing this equipment.

— Probable Cause —

— Remedy—

Hook fails to stop at end of travel	
<ol style="list-style-type: none"> 1. Limit switch not operating. 2. Brass limit switch nuts not moving on shaft. 3. Hoist reversing contactor malfunctioning. 	<ol style="list-style-type: none"> 1. Check adjustment (See LIMIT SWITCH ADJUSTMENT, page 8). Check connections against wiring diagram. Tighten loose connections or replace. 2. Check for stripped threads or bent nut guide. 3. Remove electrical cover and check reversing contactor.
Hoist does not respond to pushbutton	
<ol style="list-style-type: none"> 1. Power failure in supply lines. 2. Wrong voltage or frequency. 3. Improper connections in hoist or pushbutton station. 4. Brake does not release. 5. Faulty hoist reversing contactor 	<ol style="list-style-type: none"> 1. Check circuit breakers, switches and connections in power supply lines. 2. Check voltage and frequency of power supply against the rating on the nameplate of the motor. 3. Check all connections at line connectors and on terminal block. Check terminal block on dual voltage hoists for proper voltage connections. 4. Check connections to the solenoid coil. Check for open or short circuit. Check for proper adjustment (See BRAKE ADJUSTMENT, page 9). 5. Check coils for open or short circuit. Check all connections in control circuit. Check for burned contacts. Replace as needed.
Hook does not stop promptly	
<ol style="list-style-type: none"> 1. Hoist overloaded. 2. Brake not holding. 	<ol style="list-style-type: none"> 1. Reduce load to within rated capacity of hoist. 2. Check brake adjustment (See BRAKE ADJUSTMENT, page 9). It may be necessary to replace discs.
Hook moves in wrong direction	
<ol style="list-style-type: none"> 1. Three phase reversal. 2. Improper connections. 	<ol style="list-style-type: none"> 1. Reverse any two wires (except the green ground wire) at the power source (See INSTALLATION 3c, page 5). 2. Check all connections against wiring diagram.
Hoist hesitates to lift when energized	
<ol style="list-style-type: none"> 1. Hoist overloaded. 2. Motor brake requires adjustment. 3. Worn overload limiting clutch. 4. Low voltage. 5. Faulty SINPAC® starting switch or start capacitor (single phase hoist only). 	<ol style="list-style-type: none"> 1. Reduce load within rated capacity of hoist. 2. Check motor brake adjustment (See BRAKE ADJUSTMENT, page 9). 3. Replace clutch. 4. Determine cause of low voltage and bring up to within plus or minus 10% of the voltage specified on the motor. Measure voltage at the hoist reversing contactor while lifting a load. 5. Replace faulty component
Hook raises but will not lower	
<ol style="list-style-type: none"> 1. "DOWN" circuit open. 2. Broken conductor in pushbutton cable. 3. Faulty hoist reversing contactor. 4. Loose screw clamps. 	<ol style="list-style-type: none"> 1. Check circuit for loose connections. Check "DOWN" limit switch for malfunction. 2. Check each conductor in the cable. If one is broken, replace entire cable. 3. Check coils for open or short circuit. Check all connections in control circuit. Check for burned contacts. Replace as needed. 4. Ensure that screw clamps are tightened on the terminal blocks and reversing contactor.
Hook lowers but will not raise	
<ol style="list-style-type: none"> 1. Hoist overloaded. 2. Low voltage. 3. "UP" circuit open. 4. Broken conductor in pushbutton cable. 5. Faulty hoist reversing contactor. 6. Faulty capacitor (single phase hoist only). 7. Worn overload limiting clutch. 8. Loose screw clamps. 	<ol style="list-style-type: none"> 1. Reduce load to within rated capacity of hoist. 2. Determine cause of low voltage and bring up to within plus or minus 10% of the voltage specified on the motor. Measure voltage at the hoist reversing contactor while lifting a load. 3. Check circuit for loose connections. Check "UP" limit switch for malfunction. 4. Check each conductor in the cable. If one is broken, replace entire cable. 5. Check coils for open or short circuit, check all connections in control circuit. Check for burned contacts. Replace as needed. 6. Check starting capacitor on motor. Replace if necessary. 7. Replace overload clutch assembly. 8. Ensure that screw clamps are tightened on the terminal blocks and reversing contactor.
Motor overheats	
<ol style="list-style-type: none"> 1. Excessive load. 2. Low voltage. 3. Extreme external heating. 4. Frequent starting or reversing life. 5. Brake dragging. 	<ol style="list-style-type: none"> 1. Reduce load to within rated capacity of hoist. 2. Determine cause of low voltage and bring up to within plus or minus 10% of the voltage specified on the motor. Measure voltage at the hoist reversing contactor while lifting a load. 3. As the ambient temperature rises towards the 130°F limitation of the unit, frequency of the hoist operation must be limited to avoid overheating of the motor. See ADVERSE ENVIRONMENTAL CONDITIONS, page 4. 4. Excessive inching, jogging or reversing should be avoided since this type of operation will drastically shorten the life of motor, contactor and brake. 5. Check brake adjustment (See BRAKE ADJUSTMENT, page 9)

TROUBLESHOOTING cont'd

Lack of proper lifting speed	
<ol style="list-style-type: none"> 1. Hoist overloaded. 2. Brake dragging. 3. Low voltage. 4. Overload limiting clutch intermittently slipping. 	<ol style="list-style-type: none"> 1. Reduce load to within rated capacity of hoist. 2. Check for proper brake adjustment or other defects. 3. Ensure that the voltage at the reversing contactor is within $\pm 10\%$ of the nominal voltage while lifting a load. 4. Replace overload clutch assembly.
Motor brake noise or chatter (while starting hoist)	
<ol style="list-style-type: none"> 1. Brake needs adjustment. 2. Low voltage. 	<ol style="list-style-type: none"> 1. See BRAKE ADJUSTMENT, page 9. 2. Ensure that the voltage at the reversing contactor is within $\pm 10\%$ of the nominal voltage while lifting a load.
Motor brake "buzz" (anytime hoist is running)	
<ol style="list-style-type: none"> 1. Brake needs adjustment. 2. Broken shading coil on brake frame. 	<ol style="list-style-type: none"> 1. See BRAKE ADJUSTMENT, page 9. 2. Replace shading coil or complete brake frame assembly.

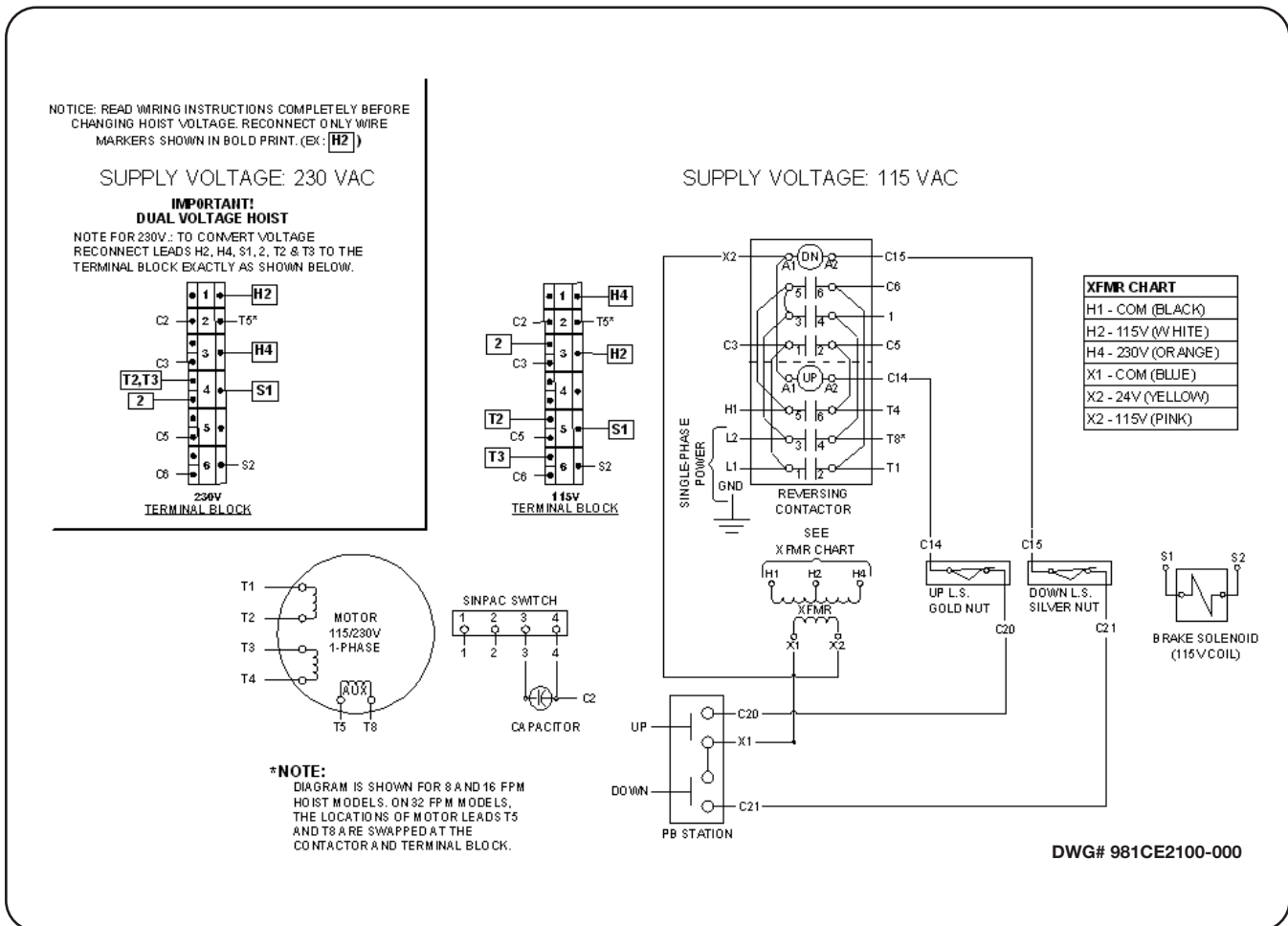

Figure 9A — Wiring Diagram for 115/230V - 1 Phase Models

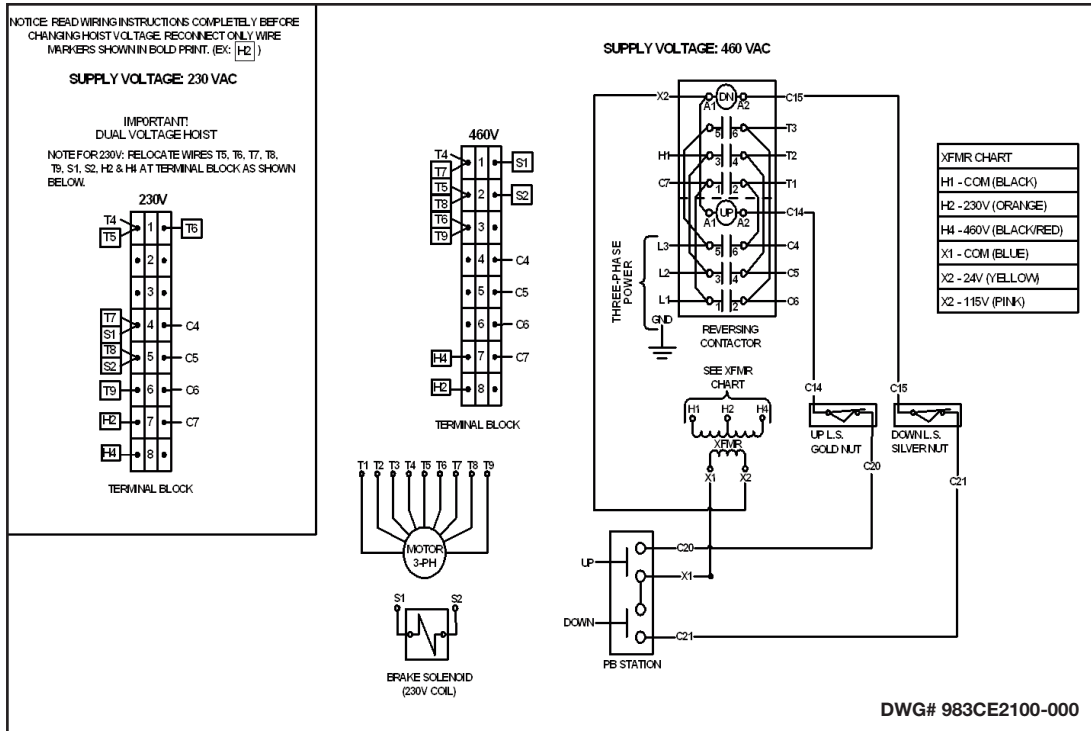

Figure 9B — Wiring Diagram for 1-Speed, 230/460V - 3 Phase Models

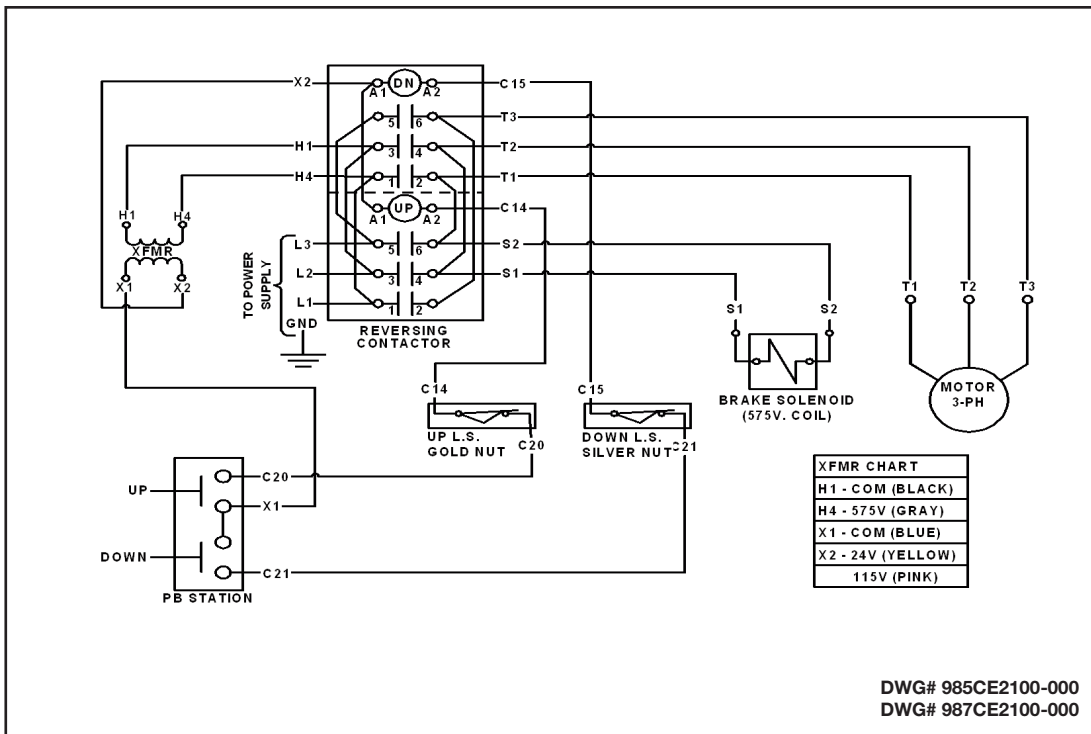

Figure 9C — Wiring Diagram for 1-Speed, 208V and 575V - 3 Phase Models
* Factory supplied diagrams will be numbered beginning with 985 for 575V and 987 for 208V.

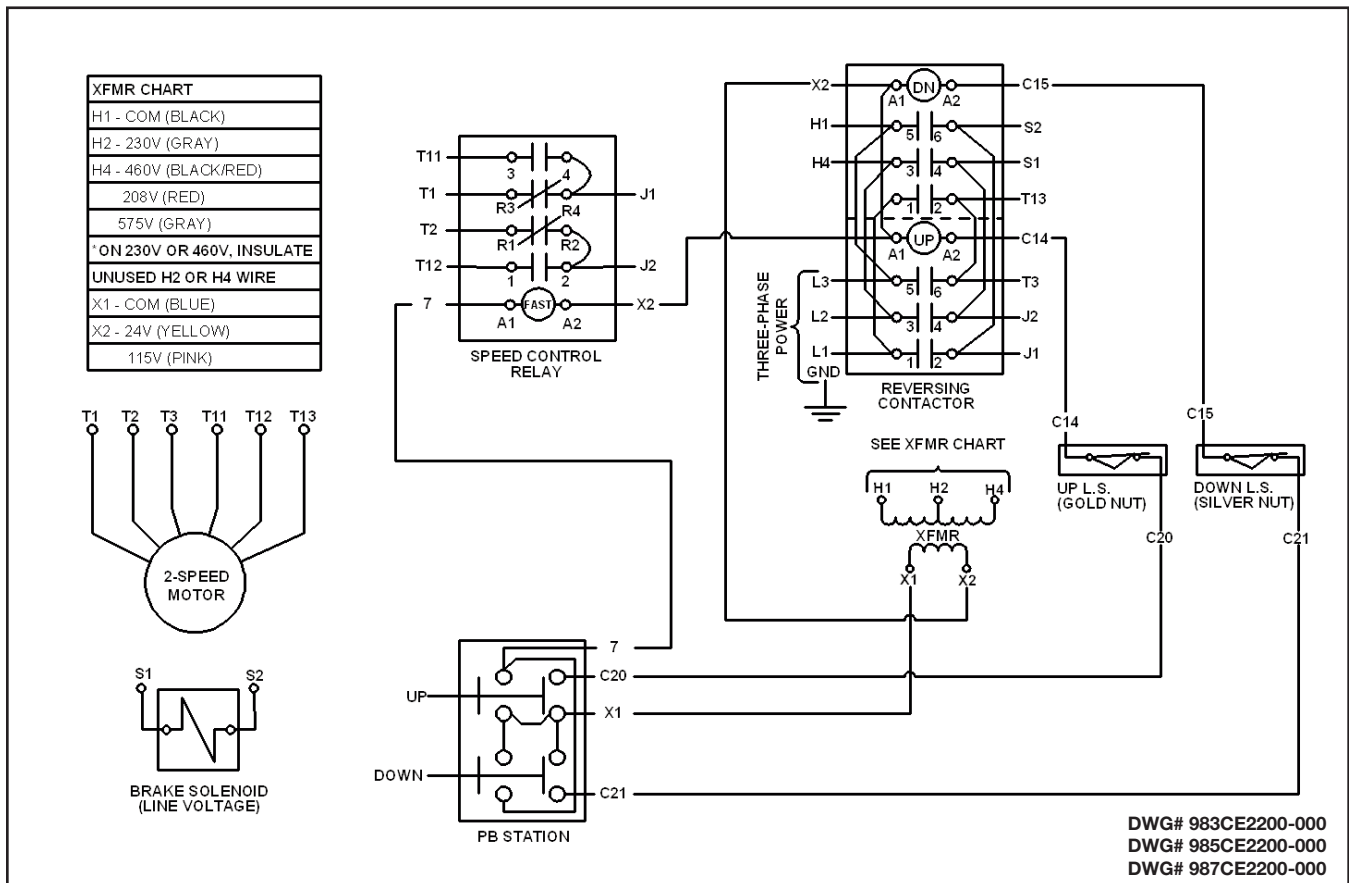

Figure 9D — Wiring Diagram for 2-Speed, 3 Phase Models

* Factory supplied diagrams will be numbered beginning with 983 for 230 or 460V, 985 for 575V and 987 for 208V.

**INSPECTION AND MAINTENANCE CHECK LIST
ELECTRIC POWERED OVERHEAD CHAIN HOIST**

Type of Hoist _____ Capacity (Tons) _____
Location _____ Original Installation Date _____
Manufacturer _____ Manufacturer's Serial No. _____

Item	Frequency of Inspection			Possible Deficiencies	OK	Action Required
	Frequent		Periodic 1-12 Mo.			
	Daily	Monthly				
Operating Controls	*	*	*	Any deficiency causing improper operation		
Limit Switches	*	*	*	1. Any deficiency causing improper operation 2. Pitting or deterioration		
Brake Mechanism	*	*	*	1. Slippage or excessive drift 2. Glazing, contamination or excessive wear		
Hooks	*	*	*	Excessive throat opening 15% bent or twisted more than 10 degrees, damaged hook latch, wear, chemical damage, worn hook bearing. Cracks (use dye penetrant, magnetic or other suitable detection method)		
Suspension Lug (if used)	*	*	*	Cracks, excessive wear or other damage which may impair the strength of the lug. Cracks (use dye penetrant, magnetic particle or other suitable detection method)		
Chain	*	*	*	Inadequate lubrication, excessive wear or stretch, cracked, damaged or twisted links, corrosion or foreign substance		
Hook and Suspension Lug Connections			*	Cracks, bending, stripped threads		
Pins, Bearings, Bushings Shafts, Couplings			*	Excessive wear, corrosion, cracks, distortion		
Nuts, Bolts, Rivets			*	Looseness, stripped and damaged threads, corrosion		
Sheaves			*	Distortion, cracks, and excessive wear. Build-up of foreign substances		
Housings, Load Block			*	Cracks, distortion. Excessive wear, internal build-up of foreign substances		
Wiring and Terminals			*	Fraying, defective insulation		
Hoist Reversing Contactor, other Electrical Apparatus			*	Loose connections, burned or pitted contacts		
Supporting Structure and Trolley (if used)			*	Damage or wear which restricts ability to support imposed loads		
Nameplates, Decals, Warning Labels			*	Missing, damaged or illegible		
Transmission Lubricant			*	Low level requires changing		

NOTE: Refer to Maintenance and Inspection Sections of the Hoist-Maintenance Manual for further details.

FREQUENCY OF INSPECTION

Frequent — Indicates items requiring inspection daily to monthly. Daily inspections may be performed by the operator if properly designated.
Periodic — Indicates items requiring inspection monthly to yearly. Inspections to be performed by or under the direction of a properly designated period. The exact period of inspection will depend on frequency and type of usage. Determination of this period will be based on the user's experience. It is recommended that the user begin with a monthly inspection and extend the periods to quarterly, semi-annually or annually based on user's monthly experience.

Figure 10A — Recommended Inspection and Maintenance Check List

NOTE: This inspection and maintenance check list is in accordance with our interpretation of the requirements of the Safety Standard for Overhead Hoists ASME B30.16. It is, however, the ultimate responsibility of the employer/user to interpret and adhere to the applicable requirements of this safety standard.

INSPECTOR'S REPORT			
ITEM	REMARKS (LIST DEFICIENCIES AND RECOMMENDED ACTION)		
Inspector's Signature	Date Inspected	Approved by	Date

Figure 10B — Recommended Inspector's Report

RECOMMENDED LUBRICATION SCHEDULE* COFFING ELECTRIC POWERED CHAIN HOIST					
PAGE AND REFERENCE NO.	COMPONENT	TYPE OF LUBRICANT	TYPE OF SERVICE AND FREQUENCY OF LUBRICATION		
			HEAVY	NORMAL	INFREQUENT
Pages 30 & 31 Ref. No. 9	Load Chain	SAE 90 gear oil	Daily	Weekly	Monthly
Pages 28 & 29	Gearing	SAE 90 extreme pressure (EP) gear oil	At periodic inspection (see Figure 10A)		
Pages 26 & 27 Ref. Nos. 9 & 7	Limit Switch Shaft	Multi-purpose oil or general purpose spray	Monthly	Yearly	Yearly
Pages 30 & 31 Ref. No. 19 & 31	Load Hook Bearing	SAE 30 gear oil or motor oil	Weekly	Monthly	Yearly
Pages 30 & 31 Ref. No. 28	Idler Sheave Bearing (Bushing) Assembly	Multi-purpose lithium base bearing grease - NLGI #2	At periodic inspection (see Figure 10A)		

NOTE: All bearings except hook and idler sheave bearings are prelubricated and sealed.
(*) This lubrication schedule is based on a hoist operating in normal environment conditions. Hoists operating in adverse atmospheres containing excessive heat, corrosive fumes or vapors, abrasive dust, etc., should be lubricated more frequently.

Figure 11 — Recommended Lubrication Schedule

Contact your nearest Coffing Service Center for parts and service. For a complete list, see pages 34 and 35. Please have the hoist model number, serial number, and part number with description available for reference.

Figure 12 - Basic Hoist

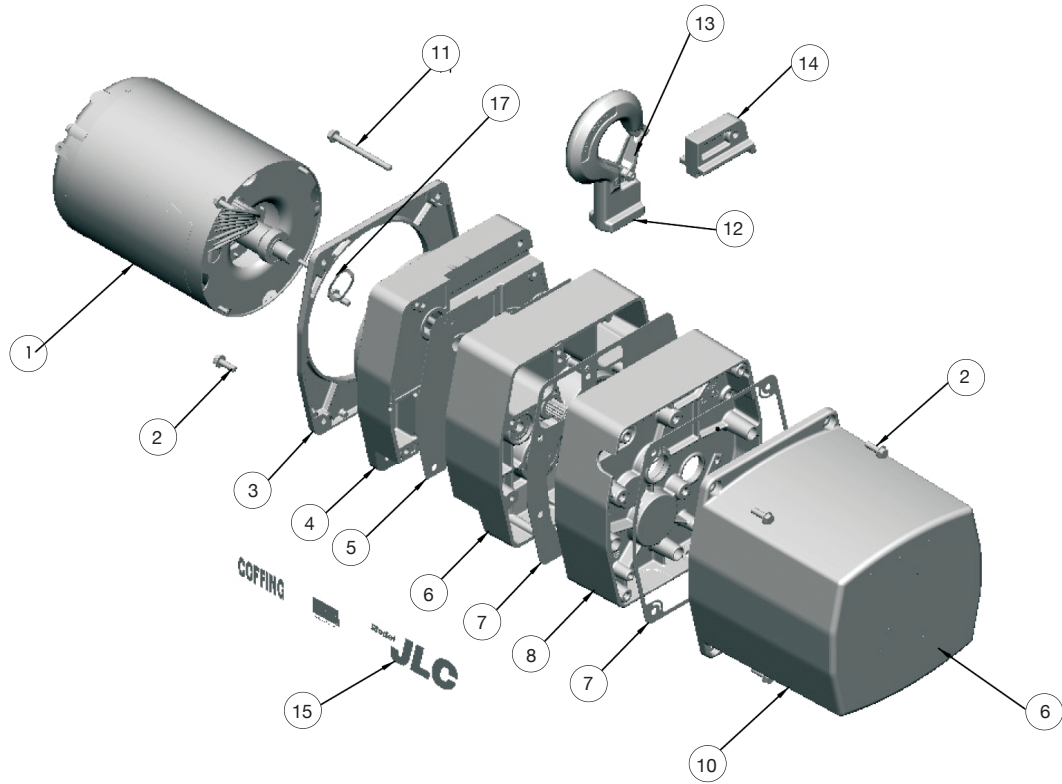

Ref. No.	Description	Part No.	Qty.	Ref. No.	Description	Part No.	Qty.
1	Motor (See Figures 13 & 14)	—	1	14	Hook Retainer	JM285	
2	Cover Screw	H2976P	7	15	JLC & Coffing Decal	JLC677-1L	1
3	Trim Cover	JM37	1			JLC677-1R	1
4	Sheave Housing	JM33-1	1	16	Capacity Decal		1
5	Sheave Housing Gasket	JM560-3	1		1/8 ton	JM675K01	1
6	Transmission Housing	JM35-1	1		1/4 ton	JM675K02	1
7	Transmission Housing Gasket	JM560-2	1		1/2 ton	JM675K05	1
8	Transmission Cover	JM34-2	1		1 ton	JM675K10	1
9	Electrical Cover Gasket	JM563	1		2 ton	JM675K20	1
10	Electrical Cover	JM36	1	17	Spring Washer	360J1	1
11	Hook Retainer Screw	H2709P	1	△	*JLCET Trolley (Lug Mounted)		
12	Top Hook Assembly with Latch				1 Ton & Under	09295	1
	Rigid Hook (Std)	3M405A01S	1		2 Ton	09296	1
	†Swivel Hook	51JM1	1	△	Suspension Lug		
13	Latch Kit Assembly	4X1305	2		Cross Mounted	JM50C	1
					Parallel Mounted	50JM1	1

(△) Not Shown
(†) Optional

(*)Suspension lug is an option for JLC Models and standard for JLCET Models.

Contact your nearest Coffing Service Center for parts and service. For a complete list, see pages 34 and 35. Please have the hoist model number, serial number, and part number with description available for reference.

Figure 13 - Hoist Motor, 115/230V - 1 Phase

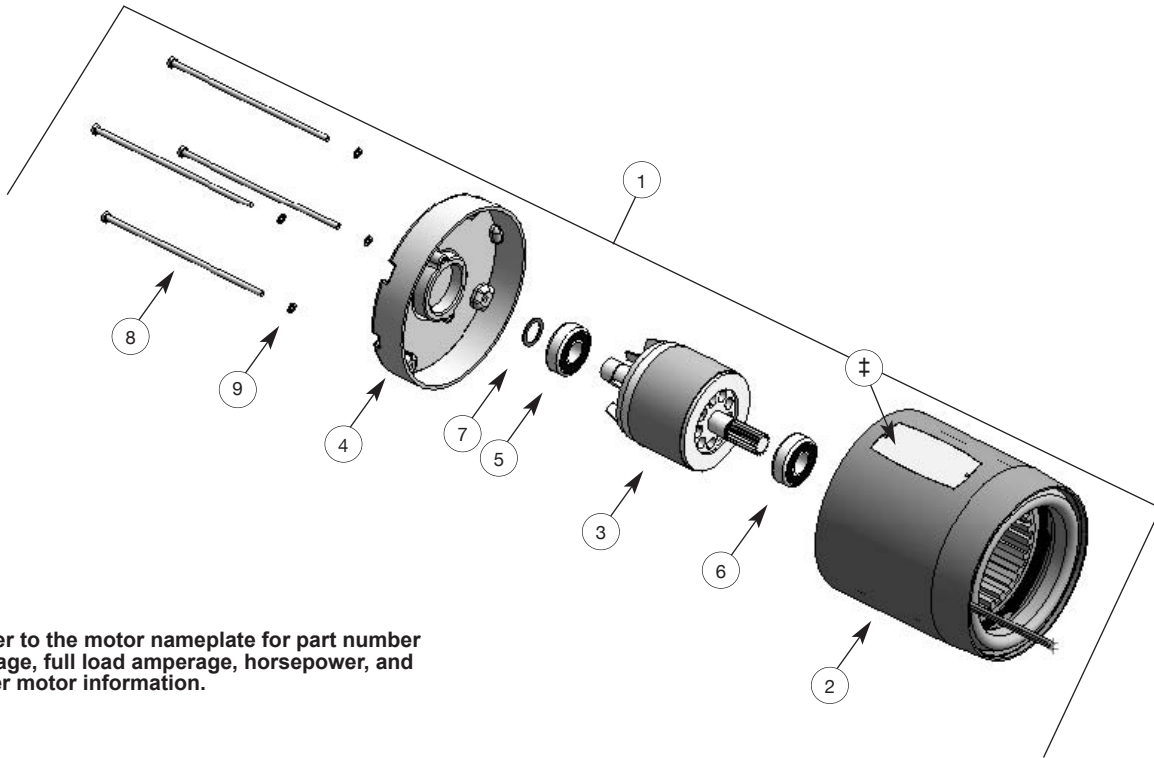

(‡) Refer to the motor nameplate for part number, voltage, full load amperage, horsepower, and other motor information.

Parts List for Hoist Motor, 115/230V - 1 Phase

Ref. No.	Part Description	Part No.	Qty.
1	Hoist Motor 1/2 hp, 115/230V-1Ph 1 hp, 115/230V-1Ph	861JR12 861JR14	1 1
2	Stator Assembly	*	1
3	Rotor Assembly	*	1
4	End Shield	*	1
5	Rear Bearing	500K3	1
6	Front Bearing	*	1
7	Shim Washer	JL4301-01	1
8	Thru Bolt	HA3100A56	4
9	#10 Spring Lockwasher	H4082P	4

* Not available as an individual part.

Contact your nearest Coffing Service Center for parts and service. For a complete list, see pages 34 and 35. Please have the hoist model number, serial number, and part number with description available for reference.

Figure 14 - Hoist Motor, 3 Phase

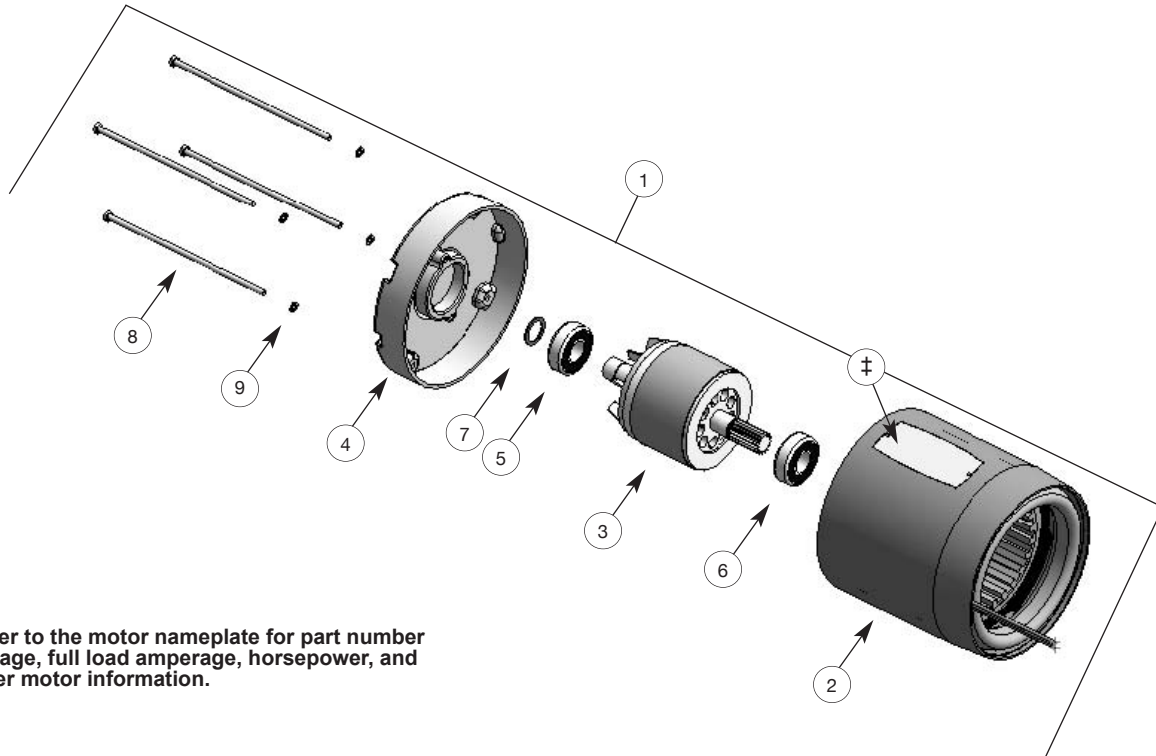

(‡) Refer to the motor nameplate for part number voltage, full load amperage, horsepower, and other motor information.

Parts List for Hoist Motor, 3 Phase

Ref. No.	Description	Part No.	Qty.	Ref. No.	Description	Part No.	Qty.
1	Hoist Motor (1-Speed)	—			1 hp, 460V-3Ph-60Hz	873JR8	1
	1/4 hp, 230/460V-3Ph-60Hz	863JR1	1		1/4 hp, 575V-3Ph-60Hz	873JR9	1
	1/2 hp, 230/460V-3Ph-60Hz	863JR2	1		1/2 hp, 575V-3Ph-60Hz	873JR10	1
	1 hp, 230/460V-3Ph-60Hz	863JR4	1		1 hp, 575V-3Ph-60Hz	873JR12	1
	1/4 hp, 575V-3Ph-60Hz	863JR5	1		1/4 hp, 208V-3Ph-60Hz	873JR13	1
	1/2 hp, 575V-3Ph-60Hz	863JR6	1		1/2 hp, 208V-3Ph-60Hz	873JR14	1
	1 hp, 575V-3Ph-60Hz	863JR8	1		1 hp, 208V-3Ph-60Hz	873JR16	1
	1/4 hp, 208V-3Ph-60Hz	863JR9	1	2	Stator Assembly	*	1
	1/2 hp, 208V-3Ph-60Hz	863JR10	1	3	Rotor Assembly	*	1
	1 hp, 208V-3Ph-60Hz	863JR12	1	4	End Shield	*	1
	Hoist Motor (2-Speed)			5	Rear Bearing	500K3	1
	1/4 hp, 230V-3Ph-60Hz	873JR1	1	6	Front Bearing	*	1
	1/2 hp, 230V-3Ph-60Hz	873JR2	1	7	Shim Washer	JL4301-01	1
	1 hp, 230V-3Ph-60Hz	873JR4	1	8	Thru Bolt (1-Speed)	HA3100A56	4
	1/4 hp, 460V-3Ph-60Hz	873JR5	1		Thru Bolt (2-Speed)	HA3100A71	4
	1/2 hp, 460V-3Ph-60Hz	873JR6	1	9	#10 Spring Lockwasher	H4082P	4

* Not available as an individual part.

Contact your nearest Coffing Service Center for parts and service. For a complete list, see pages 34 and 35. Please have the hoist model number, serial number, and part number with description available for reference.

Figure 15 - Brake & Solenoid Parts

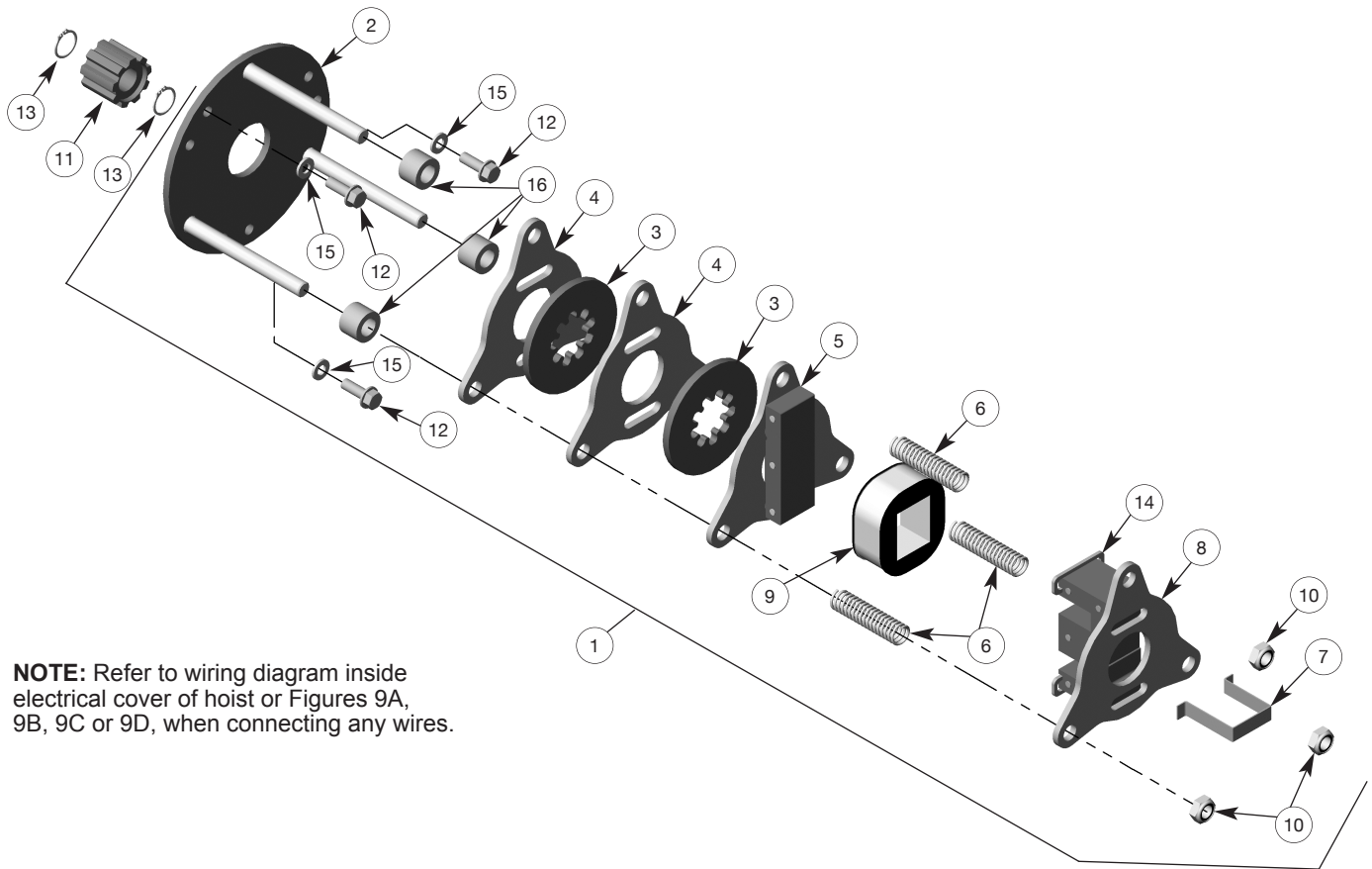

NOTE: Refer to wiring diagram inside electrical cover of hoist or Figures 9A, 9B, 9C or 9D, when connecting any wires.

Parts List for Brake & Solenoid Parts

Ref. No.	Description	Part No.	Qty.	Ref. No.	Description	Part No.	Qty.
1	Disc Brake Assembly*	—		8	Plate & Frame Assembly	JF857	1
	1 hp, 115 Volt	854JM1	1	9	Brake Coil*		
	1/4 & 1/2 hp, 115 Volt	854JM12	1		115V*	853JL1	1
	1 hp, 230 Volt	854JM2	1		230V*	853JL2	1
	1/4 & 1/2 hp, 230 Volt	854JM22	1		460V	853JL3	1
	1 hp, 460 Volt	854JM3	1		575V	853JL4	1
	1/4 & 1/2 hp, 460 Volt	854JM32	1		208V	853JL5	1
	1 hp, 575 Volt	854JM4	1	10	Locknut	H3978	3
	1/4 & 1/2 hp, 575 Volt	854JM42	1	11	Brake Hub Adapter	JM142	1
	1 hp, 208 Volt	854JM5	1	12	Screw	H2976P	3
	1/4 & 1/2 hp, 208 Volt	854JM52	1	13	Retaining Ring	H5501	2
2	Plate & Stud Assembly	859JG1	1	14	Shading Coil	860J1	2
3	Brake Disc			△	Shading Coil Adhesive	H7812	1
	1/4 & 1/2 hp	581J1A	2	15	Lockwasher	H4134	3
	1 hp	581J1A	3	16	Spacer for 1/4 & 1/2 hp	141J2	3
4	Brake Plate	JF291	2	△	Warning Decal	676J1	1
5	Plate & Armature Assembly	JF858	1				
6	Spring	344J6	3				
7	Retainer	JF710	1				

(△) Not Shown

* Dual-voltage 115/230V models use 115V Brake Assembly and Coil. Dual-voltage 230/460V models use 230V Brake Assembly and Coil.

Contact your nearest Coffing Service Center for parts and service. For a complete list, see pages 34 and 35. Please have the hoist model number, serial number, and part number with description available for reference.

Figure 16 - Electrical Parts, 1-Speed Models

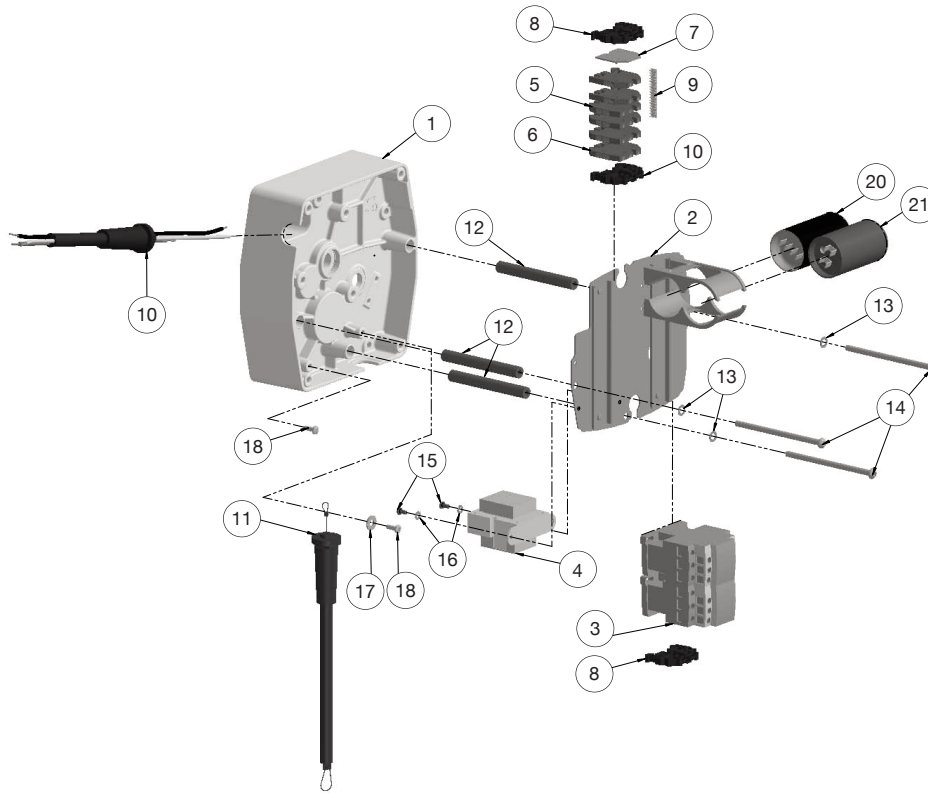

Parts List for Electrical Parts, 1-Speed Models

Ref. No.	Description	Part No.	Qty.	Ref. No.	Description	Part No.	Qty.
1	Transmission Cover	JM34-2	1	6	Terminal Block		
2	Panel Plate	257JM200	1		115/230V	909J14	4
3	Reversing Contactor*			7	End Plate		
	1/2 hp & under:		1		115/230V	909J15	1
	24V Coil	28860	1		230/460V	909J12	1
	115V Coil	24799	1	8	End Clamp		
	1 hp, 1-Phase:		1		115/230V & 230/460V	909J13	3
	24V Coil	24791	1		Single Voltage Models	909J13	1
	115V Coil	28905	1	9	Marking Strip	909J11	1
	1 hp, 3-Phase:		1	10	15 ft Power Cord Assembly		
	24V Coil	25943	1		115/230V, 1/2 hp (3 cond.)	951JL1	1
	115V Coil	24729	1		115/230V, 1 hp (3 cond.)	952JL1	1
4	Transformer*		1		3-Phase (4 cond.)	953JL3	1
	Pri.: 115/230V, Sec.: 24V	821J412	1	11	PB & Cable Assy (See Figures 18 & 19)	—	1
	Pri.: 115/230V, Sec.: 115V	821J411	1	12	Panel Standoff Spacer	200J4	3
	Pri.: 230/460V, Sec.: 24V	821J432	1	13	1/4" Internal-tooth Lockwasher	H4134	3
	Pri.: 230/460V, Sec.: 115V	821J431	1	14	1/4-20UNC X 4" Screw	H1027P	3
	Pri.: 575V, Sec.: 24V	821J452	1	15	8-32UNC X 5/16" Screw	H2751	2
	Pri.: 575V, Sec.: 115V	821J451	1	16	#8 External-tooth Lockwasher	H4158	2
	Pri.: 208V, Sec.: 24V	821J472	1	17	1/4" Flatwasher	H4002P	1
	Pri.: 208V, Sec.: 115V	821J471	1	18	10-24UNC X 1/2" Screw	H2970	2
5	Terminal Block			19†	Can Mounting Bracket	JM811	2
	115/230V	909J10	2	20†	SINPAC® Starting Switch	839J3	1
	230/460V	909J10	8	21†	Capacitor	JL810-4	1

* Coil voltage of the contactor and the secondary voltage of the transformer are the same. This is referred to as the control voltage. Standard units are supplied with 24V Control.
 (†) Single Phase units only.

Contact your nearest Coffing Service Center for parts and service. For a complete list, see pages 34 and 35. Please have the hoist model number, serial number, and part number with description available for reference.

Figure 17 - Electrical Parts, 2-Speed Models

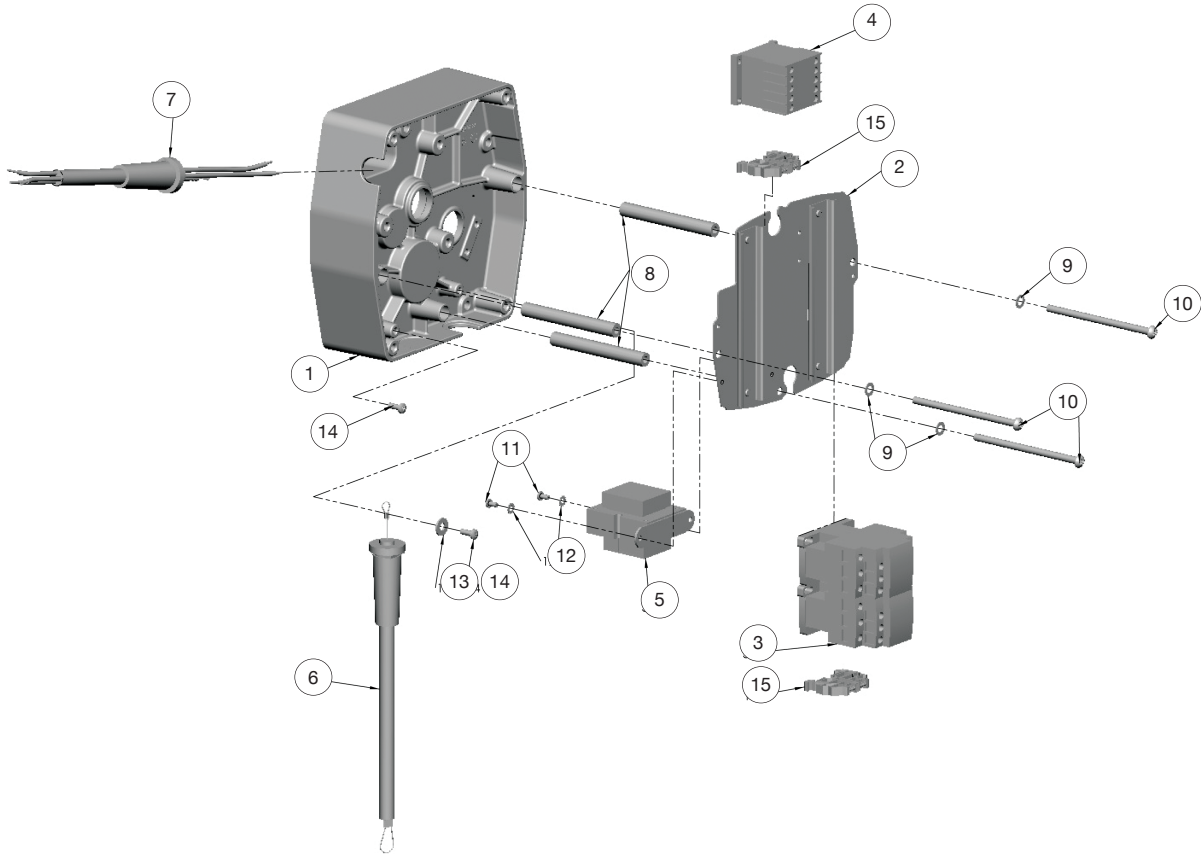

Parts List for Electrical Parts, 2-Speed Models

Ref. No.	Description	Part No.	Qty.	Ref. No.	Description	Part No.	Qty.
1	Transmission Cover	JM34-2	1		Pri.: 575V, Sec.: 24V	821J452	1
2	Panel Plate	257JM200	1		Pri.: 575V, Sec.: 115V	821J451	1
3	Reversing Contactor*				Pri.: 208V, Sec.: 24V	821J472	1
	1/2 hp & under:				Pri.: 208V, Sec.: 115V	821J471	1
	24V Coil	28860	1	6	15 ft Power Cord Assembly	953JL1	1
	115V Coil	24799	1	7	PB & Cable Assy (See Figures 18 & 19)	—	1
	1 hp, 3-Phase:			8	Panel Standoff Spacer	200J4	3
	24V Coil	25943	1	9	1/4" Internal-tooth Lockwasher	H4134	3
	115V Coil	24729	1	10	1/4-20UNC X 4" Screw	H1027P	3
4	Speed Control Relay*			11	8-32UNC X 5/16" Screw	H2751	2
	1/2 hp, 24V Coil	28878	1	12	#8 External-tooth Lockwasher	H4158	2
	1/2 hp, 115V Coil	28870	1	13	1/4" Flatwasher	H4002P	1
	1 hp, 24V Coil	28885	1	14	10-24UNC X 1/2" Screw	H2970	2
	1 hp, 115V Coil	28879	1	15	End Clamp	909J13	2
5	Transformer*						
	Pri.: 230/460V, Sec.: 24V	821J432	1				
	Pri.: 230/460V, Sec.: 115V	821J431	1				

* The coil voltage of the contactors and secondary voltage of the transformer are the same. This is referred to as the control voltage. Standard units are supplied with 24V Control.

Contact your nearest Coffing Service Center for parts and service. For a complete list, see pages 34 and 35. Please have the hoist model number, serial number, and part number with description available for reference.

Figure 18 - 1-Speed Pushbutton Station

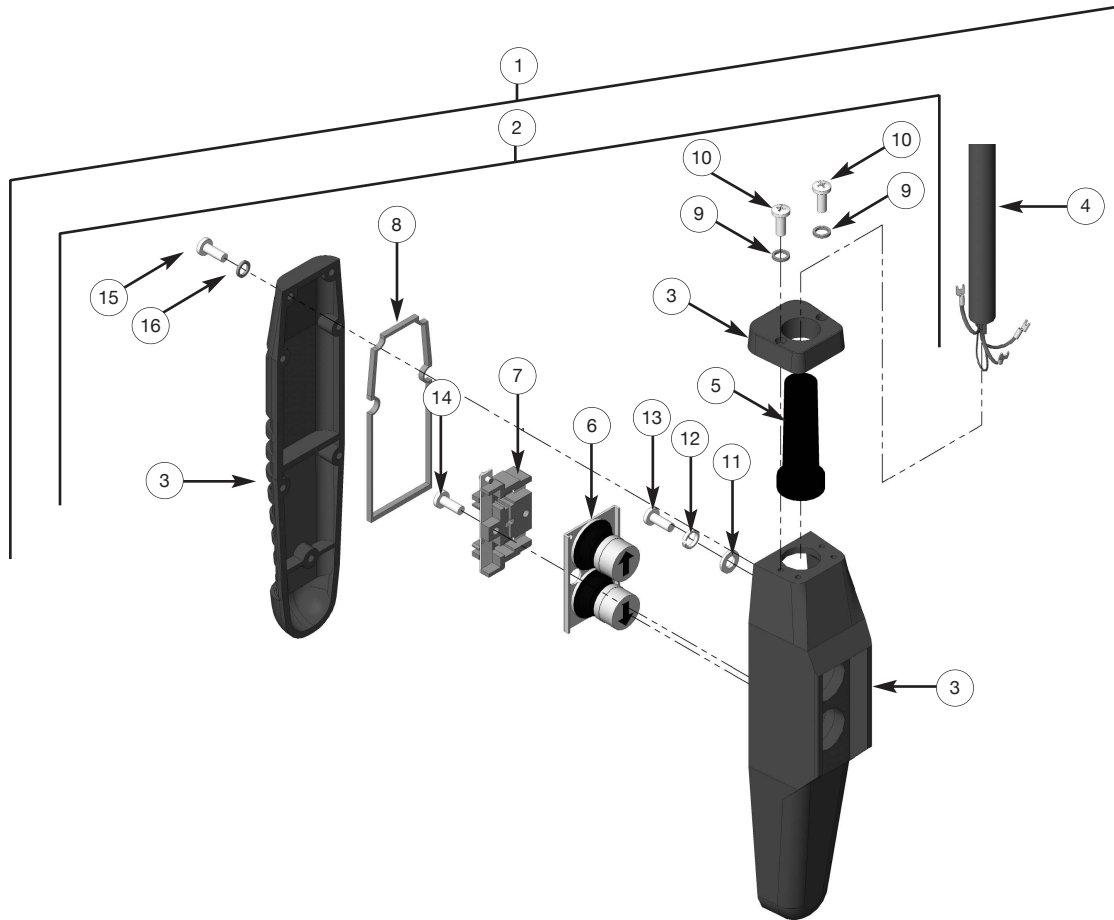

Parts List for Pushbutton, 1-Speed

Ref. No.	Description	Part No.	Qty.
1	Pushbutton Station and Control Cable Assembly		
	6 ft Cable Length	PB2100-6	1
	11 ft Cable Length	PB2100-11	1
	16 ft Cable Length	PB2100-16	1
2	Pushbutton Station Assembly (2-Button, 1-Speed)	36900R	1
3	Enclosure	36998R	1
4	Control Cable Assembly		
	6 ft Cable Length	PBC2100-6	1
	11 ft Cable Length	PBC2100-11	1
	16 ft Cable Length	PBC2100-16	1
	Special Drop	PBC2100-#	-
5	Grommet	36989	1
6	Button Assembly	-	-
7	Contact Assembly (includes items 6 & 7)	36987	1
8	Gasket	36986	1
*	Hardware Kit (includes items 9 thru 16)	36939	1
△	Warning Tag	687K3W	1

(△) Not shown.

(#) Length of Cable in Feet (pushbutton drop).

Contact your nearest Coffing Service Center for parts and service. For a complete list, see pages 34 and 35. Please have the hoist model number, serial number, and part number with description available for reference.

Figure 19 - 2-Speed Pushbutton Station

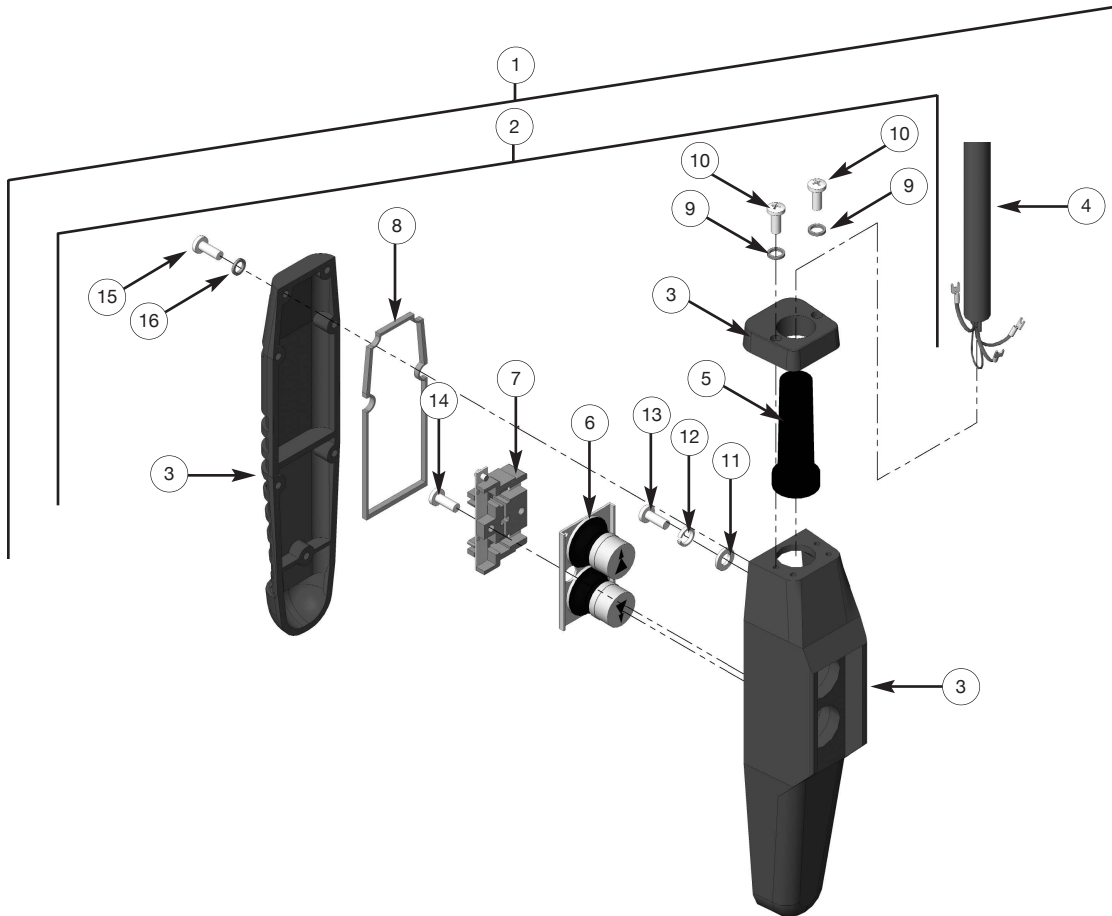

Parts List for Pushbutton, 2-Speed

Ref. No.	Description	Part No.	Qty.
1	Pushbutton Station and Control Cable Assembly		
	6 ft Cable Length	PB2200-6	1
	11 ft Cable Length	PB2200-11	1
	16 ft Cable Length	PB2200-16	1
2	Pushbutton Station Assembly (2-Button, 2-Speed)	36800R	1
3	Enclosure	36998R	1
4	Control Cable Assembly		
	6 ft Cable Length	PBC2200-6	1
	11 ft Cable Length	PBC2200-11	1
	16 ft Cable Length	PBC2200-16	1
	Special Drop	PBC2200-#	-
5	Grommet	36866	1
6	Button Assembly	-	-
7	Contact Assembly (includes items 6 & 7)	70964	1
8	Gasket	36986	1
*	Hardware Kit (includes items 9 thru 16)	36939	1
△	Warning Tag	687K3W	1

(△) Not shown.

(#) Length of Cable in Feet (pushbutton drop).

Contact your nearest Coffing Service Center for parts and service. For a complete list, see pages 34 and 35. Please have the hoist model number, serial number, and part number with description available for reference.

Figure 20 - Limit Switch Assembly

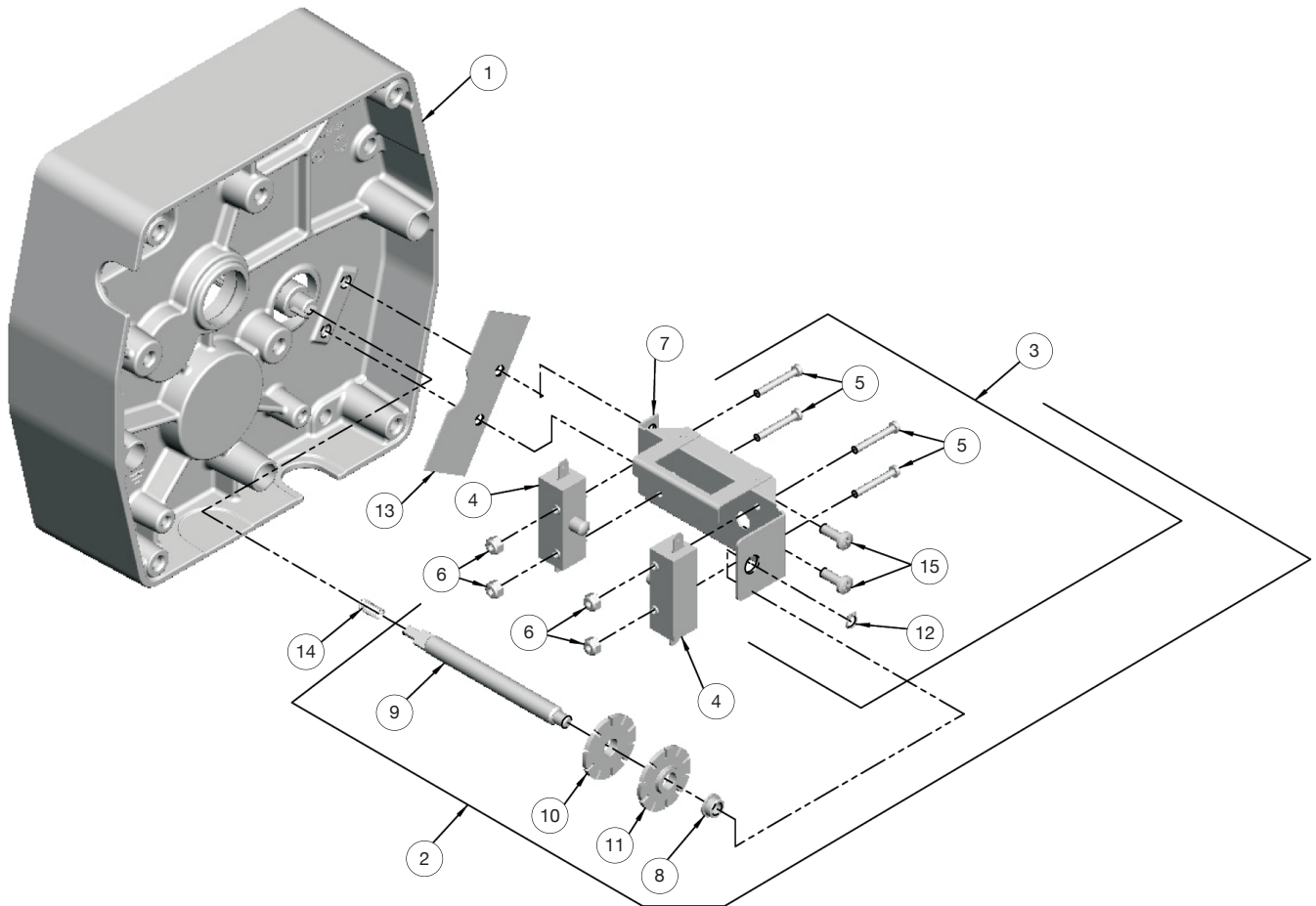

Parts List for Limit Switch Assembly

Ref. No.	Description	Part No.	Qty.	Ref. No.	Description	Part No.	Qty.
1	Transmission Cover	JM34-2	1	8	Bushing	JF531-4	1
2	Limit Switch Assembly (Includes items 4-12)	918JG4	1	9	Limit Switch Shaft	JF117-3S	1
3	Limit Switch Bracket Assembly (Includes items 4-8)	918JG3	1	10	Limit Switch Nut (silver)	SK6000-63Z	1
4	Switch	815J1	2	11	Limit Switch Nut (gold)	SK6000-63W	1
5	6-32UNC X 1" Screw	H1402P	4	12	Retaining Ring	H5520	1
6	6-32UNC Elastic Locknut	H3944	4	13	Insulator	JF754	1
7	Limit Switch Bracket & Guide Assembly (Includes Item 8)	JF900-3	1	14	Spring	JF343-3	1
				15	10-24UNC X 1/2" Screw	H2970	2

Contact your nearest Coffing Service Center for parts and service. For a complete list, see pages 34 and 35. Please have the hoist model number, serial number, and part number with description available for reference.

Figure 21 - Long Lift Limit Switch Parts

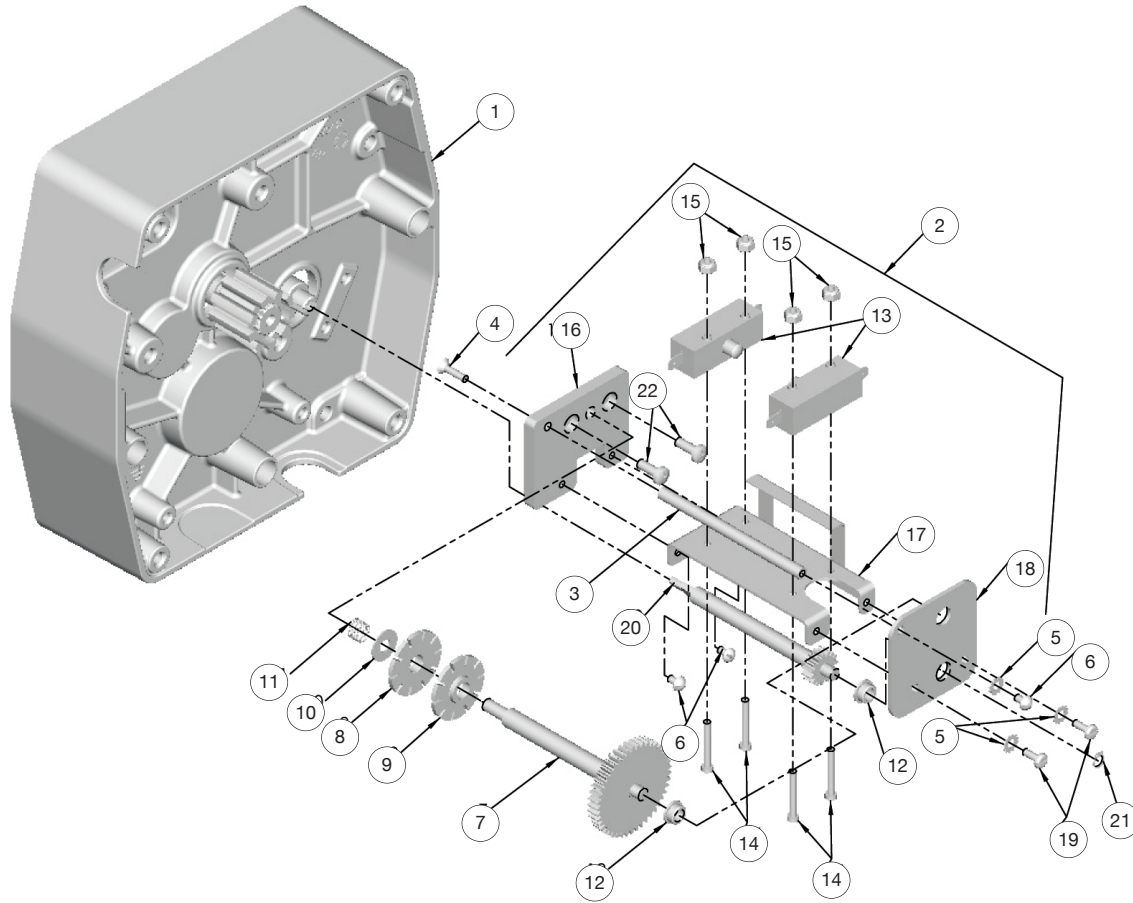

Parts List for Long Lift Limit Switch Parts

Ref. No.	Description	Part No.	Qty.	Ref. No.	Description	Part No.	Qty.
1	Transmission Cover	JM34-2	1	12	Bushing	JF531-4	2
2	Limit Switch Assembly (Includes items 3-21)	944JG6	1	13	Switch	815J1	2
3	Post	110J14	1	14	6-32UNC X 1" Screw	H1402P	4
4	8-32UNC X 1/2" Screw	H1210	1	15	6-32UNC Elastic Locknut	H3944	4
5	#8 External-tooth Lockwasher	H4158	3	16	Mounting Plate	129J1	1
6	8-32UNC X 1/4" Screw	854823	3	17	Frame and Guide Assembly	258JG7	1
7	Limit Switch Shaft & Gear	117JG2	1	18	End Plate	258J8	1
8	Limit Switch Nut (gold)	SK6000-63W	1	19	8-32UNC X 3/8" Screw	H2741P	2
9	Limit Switch Nut (silver)	SK6000-63Z	1	20	Drive Pinion	427J1	1
10	Thrust Washer	255K16	1	21	Retaining Ring	H5520	1
11	Spring	PB287	1	22	10-24UNC X 3/8" Screw	H2981P	2

Contact your nearest Coffing Service Center for parts and service. For a complete list, see pages 34 and 35. Please have the hoist model number, serial number, and part number with description available for reference.

Figure 22 - Transmission

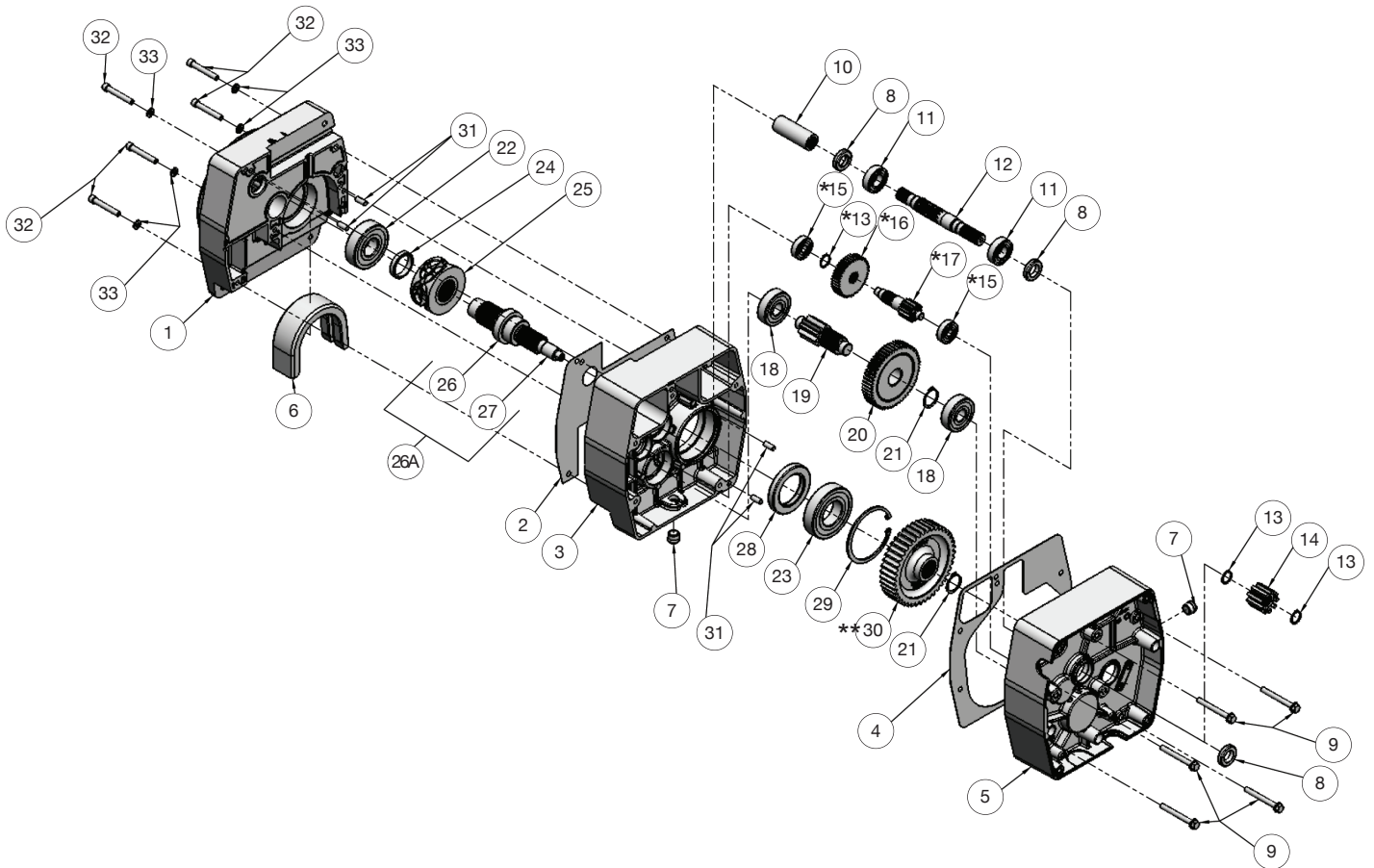

(*) NOTE: This stage of gearing is not required on 32 FPM models.

(**) NOTE: Orient output gear (30) with long boss towards transmission cover (5) on all models.

Contact your nearest Coffing Service Center for parts and service. For a complete list, see pages 34 and 35. Please have the hoist model number, serial number, and part number with description available for reference.

Parts List for Transmission

Ref. No.	Part Description	Part No.	Qty.
1	Sheave Housing	JM33-1	1
2	Sheave Housing Gasket	JM560-3	1
3	Transmission Housing	JM35-1	1
4	Transmission Housing Gasket	JM560-2	1
5	Transmission Cover	JM34-2	1
6	Chain Guide	JM273	1
7	Oil Plug - Drain/Fill	H6297	2
8	Oil Seal	561K2	3
9	Screw Hex Washer Head Self-threading	H2693P	5
10	Motor Coupling	JM107	1
11	Bearing	500K33	2
12	Input Pinion		
	8 & 16 fpm	JL400B	1
	32 fpm	JL400-1	1
13	Retaining Ring	H5501	3
14	Brake Hub Adapter	JL142	1
15	Bearing for 8 & 16 fpm	500K34	2
16	High Speed Gear for 8 & 16 fpm	JL426	1
17	Intermediate Pinion		
	1/4 & 1/2 ton, 16 fpm	JL402A	1
	1 & 2 ton	JL403A	1
18	Bearing	500K39	2
19	Output Pinion	JL401	
20	Overload Clutch Assembly		
	1/8 ton, 32 fpm	591JG22	1
	1/4 ton, 16 fpm	591JG25	1
	1/4 ton, 32 fpm	591JG22	1
	1/2 ton, 16 fpm	591JG16	1
	1/2 ton, 32 fpm	591JG21	1
	1 & 2 ton	591JG17	1
21	Retaining Ring	H5503	1
22	Bearing	500K28	1
23	Bearing	500K40	1
24	Spacer-Load Sheave	JM127	1
25	Load Sheave - 9/32" Dia Chain	JF16-3	1
26A	Load Sheave Shaft Assembly (Item 26 & 27)	132JM1	1
26	Load Sheave Shaft	JM132	1
27	Stub Shaft - Limit Switch Drive	JM140	1
28	Oil Seal	011612800	1
29	Retaining Ring	H5598	1
30	Output Gear	JL421	1
31	Dowel Pin	H5382	4
32	Socket Head Cap Screw 1/4" Dia.	S49-10	5
33	Lock Washer, Medium 1/4" Dia.	H4084P	5
*	Gear Oil		1 qt.

* Not Shown

Contact your nearest Coffing Service Center for parts and service. For a complete list, see pages 34 and 35. Please have the hoist model number, serial number, and part number with description available for reference.

Figure 23 - Chaining Parts

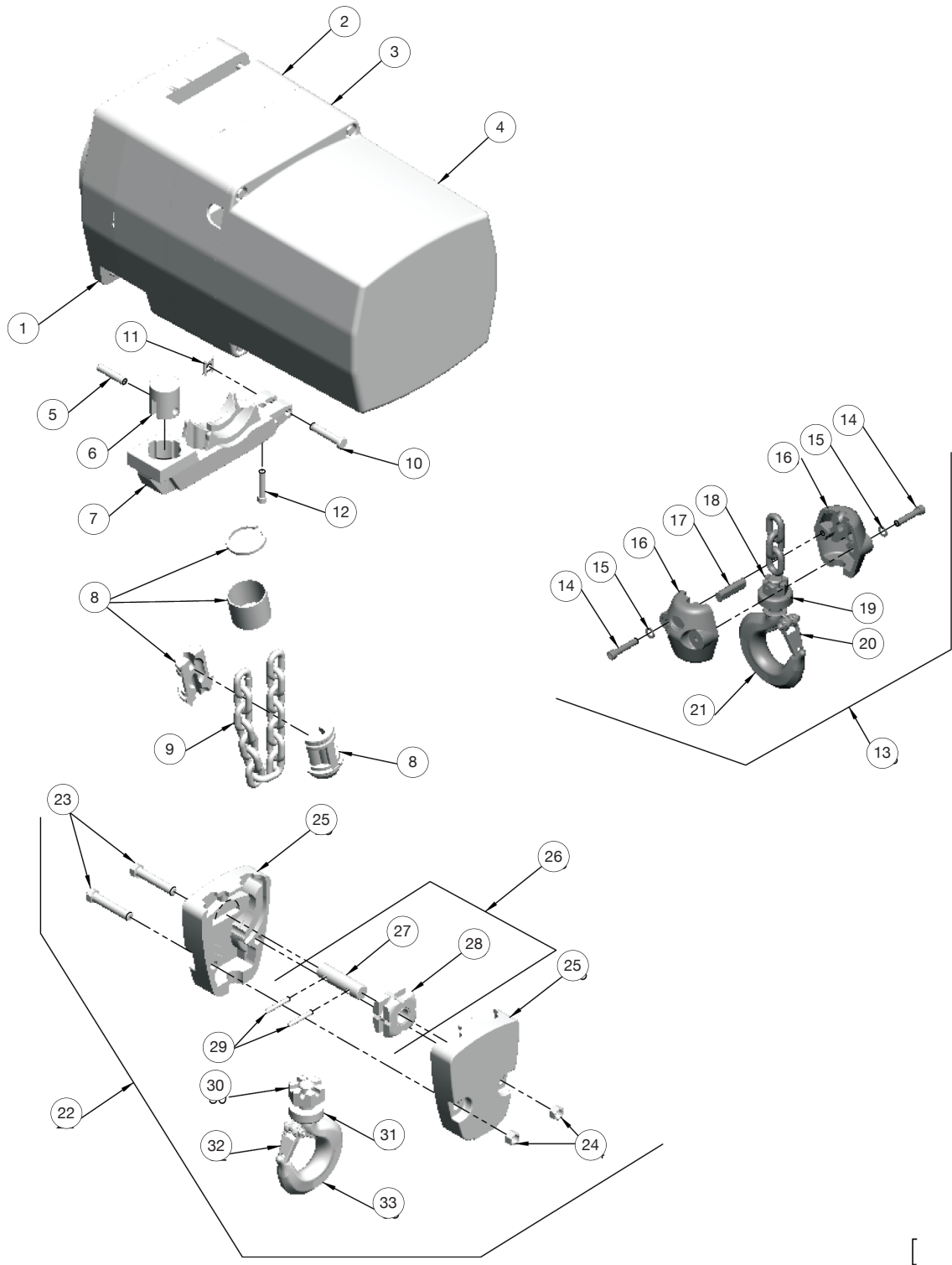

Contact your nearest Coffing Service Center for parts and service. For a complete list, see pages 34 and 35. Please have the hoist model number, serial number, and part number with description available for reference.

Parts List for Chaining Parts

Ref. No.	Part Description	Part No.	Qty.
1	Sheave Housing	JM33-1	1
2	Transmission Housing	JM35-1	1
3	Transmission Cover	JM34-2	1
4	Electrical Cover	JM36	1
5	Chain Support Pin (2 ton only)	JM111	1
6	Chain Support (2 ton only)	JM109	1
7	Chain Stripper	JM254	1
8	Chain Stop Kit (Kits include halves, sleeve and retaining ring)	75JG6K	1
9	Load Chain	JL19-1	*
10	Attachment Pin	JM18-3	1
11	Retaining Clip	H5597	1
12	1/4-20UNC x 1 1/4" Socket Head Cap Screw	S49-77	1
13	Bottom Block Assembly 1 ton & Under	913JG3AS	1
14	1/4-20UNC x 1 1/4" Socket Head Cap Screw	S49-77	2
15	1/4" Internal-tooth Lockwasher	H4134	2
16	Load Block Frame	30J14	2
17	Load Block Pin	18J8	1
18	Slotted Hex Nut	H3986P	1
19	Bearing	JF510	1
20	Latch Kit	4X1304	1
21	Bottom Hook Assembly with Latch for 1 Ton & Under	3JG20S	1
22	Bottom Block Assembly for 2 Ton	JF914-6	1
23	3/8-24 Hex Locknut	H3964P	2
24	Load Block Screw	H2403P	2
25	Load Block Frame	JF30-1	2
26	Sheave Shaft Assembly	JF917-1	1
27	Sheave Shaft	JF122-1	1
28	Idler Sheave & Bearing Assembly	JF916	1
29	Roll Pin	H5234	2
30	3/8-24 Hex Locknut	H3991P	1
31	Bearing	JF511	1
32	Latch Kit	4X1305	1
33	Bottom Hook Assembly with Latch for 2 Ton	3KG1W	1

* Replacement chain is sold by the foot. For single-chained models, add 2 ft to the lift for the total amount of feet. For double-chained models, double the lift and add 3 ft.

Country Club Road
P.O. Box 779
Wadesboro, NC 28170 USA
TEL: (800) 477-5003
FAX: (800) 374-6853

COFFING AUTHORIZED WARRANTY REPAIR CENTERS AND PARTS DEPOTS

As a Coffing Hoist user, you are assured of reliable repair and parts services through a network of Master Parts Depots and Service Centers that are strategically located across the United States, its territories and Canada. These facilities have been selected on the basis of their demonstrated ability to handle all parts and repair requirements promptly and efficiently.

Below is a list of the Coffing Authorized Warranty Repair Centers and Parts Depots located in United States, its territories and Canada. To quickly obtain the name of a Service Center located nearest you, call (800) 477-5004. Fax: (800) 374-6853. In the following list, the Canadian Service Centers are indicated.

UNITED STATES

ALABAMA

****TOOL SMITH CO.**
1300 4th Ave.S.
Birmingham AL 35233
(205) 323-2576 or (800) 317-8665
Fax (205) 323-9060

ARKANSAS

****HI-SPEED HOIST & CRANE**
701 N. Maple St.
N. Little Rock AR 72114
(501) 375-9178 Fax (501) 375-4254

**HANDLING SYSTEMS & CONVEYORS INC

10909 East Otter Creek Rd.
Mabelville AR 72103
(501) 455-5898 Fax (501) 455-6179

ARIZONA

****MECHANICS TOOL SERVICE**
1301 E. Apache Park Place
Tucson AZ 85714
(520) 889-8484 AZ only (800) 372-6700
Fax (520) 889-6668

CALIFORNIA

****ARROW CRANE HOIST CORP.**
12714 South Carmenita Road
Santa Fe Springs CA 90670
(562) 921-8328 Fax (562) 921-9307

**IDG. CALIFORNIA

6842 Walker Street
LaPalma CA 90623
(714) 994-6960 or (800) 464-5669
Fax (714) 521-0105

**CRANENETWORKS, INC.

2585 Nicholson Street
San Leandro CA 94577
(510) 357-4000 Fax (510) 357-4099

**KIMMERLE BROTHERS, INC.

12060 East Florence St.
Santa Fe Springs CA 90670
(562) 946-6771 Fax (562) 944-3473

**KIMMERLE BROTHERS, INC.

226 11th St.
San Francisco CA 94103
(415) 431-1163 Fax (415) 431-1693

**KIMMERLE BROTHERS, INC.

337 "M" St.
Fresno CA 93721
(559) 233-1278 Fax (559) 233-4678

COLORADO

****CRANE REPAIR CO.**
3718 Norwood Drive
Littleton CO 80125
(303) 791-7918 or (800) 878-7918
Fax (303) 791-7179

FLORIDA

****J. HERBERT CORP.**
1751 S. John Young Parkway
Kissimmee FL 32741
(407) 846-0588 or (800) 255-0588
Fax (407) 846-8042

**MATERIAL HANDLING SYSTEMS

720 S.W. 4th Court
Dania FL 33004
(954) 921-1171 or (888) 424-6478
Fax (954) 921-7117

GEORGIA

****ACE INDUSTRIES INC.**
6295 McDonough Drive
Norcross GA 30093
(770) 441-0898 or (800) 733-2231
Fax (800) 628-3648

*GAFFEY INC.

471 Sessions St.
Marietta GA 30060
(770) 939-6443 or (800) 820-6443
Fax (770) 422-2255

ILLINOIS

****INDUSTRIAL TOOL PRODUCTS**
919 N. Central Ave.
Woodale IL 60191
(630) 766-4040 or (800) 525-9654
Fax (630) 766-4166

*S & K AIR POWER

Rt. 316 E., Box 1279
Mattoon IL 61938
(217) 258-8500 (IL only-800-955-8501)
Fax (217) 258-8571

**SIEVERT ELECTRIC SERVICE

1230 South Hannah
Forest Park IL 60130
(708) 771-1600 or (800) 322-9144
Fax (708) 771-3124

INDIANA

****BREHOB CORP.**
1334 S. Meridian St.
Indianapolis IN 46225
(317) 231 8080 or (800) 632-4451
Fax (317) 231-8072

**MATERIALS HANDLING EQUIPMENT

7433 US 30 East
Fort Wayne IN 46803
(219) 749-0475 or (800) 443-6432
Fax (219) 749-0481

IOWA

****ALTER & SONS, INC.**
514 S. Howell St.
Davenport IA 52808
(563) 323-3601 or (800) 553-1111
Fax (563) 324-0138

KENTUCKY

****ADVANCED SHERMAN**
330 North Spring St.
Louisville KY 40206
(502) 896-2166 (KY only-800-633-8186)
Fax (502) 897-9837

LOUISIANA

****RENTAL SERVICE**
3301 Cities Service Hwy
West Lake LA 70669
(337) 882-6011
Fax (337) 882-0527

**DRILLCO

12649 S. Choctaw Dr.
Baton Rouge LA 70815
(225) 272-8251 or (800) 851-3821
Fax (800) 315-9225

MASSACHUSETTS

****ABEL DISTRIBUTORS INC.**
50 Parker St.
Newbury Port MA 01950
(978) 463-0700
Fax (978) 463-5200

MICHIGAN

***COMMERCIAL GROUP**
9955 Grand River
Detroit MI 48204
(313) 931-6100 or (800) 931-7701
Fax (313) 491-1753

**CONTINENTAL CRANE & SERVICE CO.

33681 Groesbeck Hwy.
Fraser MI 48026
(586) 293-3870 Fax (586) 293-0017

**STEWART ENGINEERING & SALES

2140 Aurora Ave.
Muskegon MI 49442
(231) 767-2140 Fax (231) 767-2233

MINNESOTA

****ELECTRIC MOTOR REPAIR, INC.**
2010 N. 4th St.
Minneapolis MN 55411
(612) 522-3318 or (800) 345-0198
Fax (612) 588-1617

**J & B EQUIPMENT

8200 Grand Avenue South
Bloomington MN 55420
(952) 884-2040 Fax (952) 346-1139

***PERFECTION CRANE & HOIST INC.

201 DeGraff Ave.
Swanville MN 56382
(320) 547-2401 or (800) 253-6829
Fax (800) 353-2254

**TOTAL TOOL SUPPLY

315 N. Pierce St.
St. Paul MN 55104
(952) 646-4055 or (800) 444-4899
Fax (952) 646-8610

MISSOURI

****HERTZ EQUIPMENT RENTAL & SUPPLY**
800 E. 18th St.
Kansas City MO 64108
(816) 221-7788 or (800) 669-7788
Fax (816) 221-0817

**HANDLING SYSTEMS INC.

11678 Gravois Rd.
St. Louis MO 63126
(314) 842-7263 Fax (314) 842-5041

**ZELLER ELECTRIC

4250 Hoffmeister
St. Louis MO 63125
(314) 638-9641 (Outside MO (800) 530-5810)
Fax (314) 638-6318

MONTANA

****POWER SERVICE OF MONTANA, INC.**
4025 1st Ave.
Billings Montana 59101
(406) 252-8114 or (800) 823-8665
Fax (406) 259-3956

UNITED STATES

NEW JERSEY

**SISSCO
186 Route 206 South
Hillsborough NJ 08844
(908) 359-9767 or (800) 392-0146
Fax (908) 359-9773

NEW YORK

**ABC ELECTRIC
24-25 46th Street.
Long Island City NY 11103
(718) 956-0000 or (N.Y. only-800-562-1919)
FAX (718) 956-4455

**BEATON INDUSTRIAL, INC.
6083 Trenton Rd.
Utica NY 13502
(315) 797-9346 (N.Y. only-800-724-4052)
Fax (315) 797-9321

**VOLLAND ELECTRIC EQUIPMENT CO.
75 Innsbruck Drive
Buffalo NY 14227
(716) 656-9900 Fax (716) 656-8899

NORTH CAROLINA

**CAROLINA HOIST
3310 E. Wendover Avenue
Greensboro NC 27405
(336) 375-6050 or (800) 326-3655
Fax (336) 375-6053

**SOUTHERN ELECTRIC SERVICE
2225 Freedom Drive
Charlotte NC 28266
(704) 372- 4832 or (800) 487-3726
Fax (704) 342-2604

OHIO

**CRANE AMERICA - H. W. HOUSE
920 Deneen Avenue
Monroe OH 45050
(513) 539-9770 or (800) 331-5326
Fax (513) 539-9577

**AMERICRANE & HOIST CORP.
13224 Enterprise Avenue
Cleveland OH 44135
(216) 267-9100 or (800) 652-1932
Fax (216) 267-9131

*SAMSEL SUPPLY CO.
1285 Old River Road
Cleveland OH 44113
(216) 241-0333 or (800) 892-8012
Fax (216) 241-3426

OKLAHOMA

**GAFFEY INC.
9655 E. 522 Road
Claremore OK 74017
(918) 343-1191 or (800) 331-3916
Fax (918) 343-7304

OREGON

**GENERAL TOOL & SUPPLY CO.
2705 N.W. Nicolai
Portland OR 97210
(503) 226-3411 or (800) 783-3411
Fax (503) 778-5518

PENNSYLVANIA

**AMERICRANE
1558 Myers Road
Indiana PA 15701
(888) 963-9900 or (724) 479-9100

**GLOBE ELECTRIC CO.
200 23rd Street
Pittsburgh PA 15215
(412) 781-2677 or (800) 850-4440
Fax (412) 781-1812

PENNSYLVANIA (cont'd)

*KEYSTONE CRANE & HOIST CO.
861 S. Washington Road
McMurray PA 15317
(724) 746-5080 Fax (724) 746-5082

**MCDAL CORP.
475 East Church Road
King of Prussia PA 19406
(610) 277-5484 or (800) 626-2325
Fax (610) 277-4690

**MORRIS MATERIAL HANDLING
Tinicum Ind. Park Building E
10 Industrial Highway MS 80
Lester PA 19113
(800) 346-2098
Fax (610) 521-5907

**REPAIR UNLIMITED
1730 Rockwell Road
Abington PA 19001
(215) 657-3335 or (800) 369-5891
Fax (215) 784-0343

RHODE ISLAND

**MOTORS , HOIST & CONTROLS INC.
179 Railroad Street
Woonsocket RI 02895
(401) 767-4568 Fax (401) 767-4567

SOUTH CAROLINA

**ENGINEERED SYSTEMS, INC.
1121 Duncan-Reidville Road
Duncan SC 29334
(864) 879-7438 or (800) 879-7438
Fax (864) 848-3143

TENNESSEE

**HOIST & CRANE CO.
2508 Perimeter Place
Nashville TN 37214
(615) 242-3383 or (888) 464-7811
Fax (615) 255- 4379

**HI-SPEED ELECTRICAL CO.
3013 Thomas Street
Memphis TN 38127
(901) 357-6231 Fax (901) 357-6238

TEXAS

**ABEL EQUIPMENT CO., INC.
3710 Cavalier Drive
Garland TX 75042
(972) 272-7706 Fax (800) 272-2235

**GAFFEY, INC.
4301 Garland Drive
Ft. Worth TX 76117
(817) 281-1994 or (800) 284-4233
Fax (817) 581-7831

**GAFFEY, INC.
4003 S. County Road 1297
Odessa TX 79765
(915) 563-2897 or (800) 733-0006
Fax (915) 563-4703

**GAFFEY, INC.
1436 N. Duck Creek Road
Cleveland TX 77327
(281) 443-6690 or (800) 233-8179
Fax (281) 592-6984

**HYDRAULIC EQUIPMENT SER.
1021 N. San Jacinto Street
Houston TX 77002
(713) 228-4073 Fax (713) 228-0931

UTAH

**ROCKY MOUNTAIN WIRE ROPE & RIG.
2421 South 2570 West
Salt Lake City UT 84119
(801) 972-4972 or (800) 615-3193
Fax (801) 974-0621

VIRGINIA

**FOLEY MATERIAL HANDLING CO.
11327 Va. Crane Drive
Ashland VA 23005
(804) 798-1343 Fax (804) 798-7843

WISCONSIN

**ALFERI INDUSTRIAL SALES &
SERVICE
346 Smith Street
Neenah WI 54956
(920) 722-6483 Fax (920) 722-6489

*LIFT INC.
6667 W. Mill Road
Milwaukee WI 53218
(414) 353-5353 or (800) 728-5438
Fax (414) 353-4444

*TRESTER HOIST & EQUIPMENT
W136 N4863 Campbell Dr. Suite 4
Menomonee Falls WI 53051
(262) 790-0700 or (800) 234-6098

CANADA

Fax (262) 790-1009

ALBERTA

**KRISTIAN ELECTRIC
4215-64 Avenue SE
Calgary Alberta T2C 2C8
(403) 292-9111

BRITISH COLUMBIA

***AIR BRAKE REPAIR
144 W. 5th Avenue
Vancouver British Columbia V5Y 1H7
(604) 879-7754

MANITOBA

***B & B DYNAMO
575 McTavish Street
Winnipeg Manitoba R2J 2W5
(204) 237-6066

ONTARIO

**TORONTO ELECTRIC
72 Crockford Blvd
Scarborough Ontario M1R 3C4
(416) 755-7716

**PRO-CRANE HOIST REPAIRS INC.
2050 Speers Road, Unit 2
Oakville Ontario L6L 2X8
(905) 825-2586

QUEBEC

**LEGER
7995 17th Avenue
Montreal Quebec H1Z 5R2
(514) 376-3050

**UPTOWN LEE
460 Hubert Street
Laval Quebec H7G 2Y9
(514) 667-1859

*PARTS DEPOT & REPAIR CENTERS

**PARTS DEPOT & WARRANTY REPAIR CENTER

***PARTS DEPOT

COFFING® WARRANTY



Every hoist is thoroughly inspected and performance tested prior to shipment from the factory. If any properly installed, maintained and operated hoist as outlined in the applicable accompanying Coffing Hoists manual develops a performance problem due to defective materials or workmanship as verified by Coffing Hoists, repair or replacement of the hoist will be made to the original purchaser without charge and the hoist will be returned, transportation prepaid. This warranty does not apply where deterioration is caused by normal wear, abuse, improper or inadequate power supply, improper or inadequate maintenance, eccentric or side loading,

overloading, chemical or abrasive actions, excessive heat, unauthorized modifications or repairs, or use of non-Coffing repair parts. **EXCEPT AS STATED HEREIN, COFFING HOISTS MAKES NO OTHER WARRANTIES, EXPRESS OR IMPLIED, INCLUDING WARRANTIES OF MERCHANTABILITY AND FITNESS FOR A PARTICULAR PURPOSE.**

WARNING

Overloading and Improper Use Can Result In Injury

To Avoid Injury:

- Do not exceed working load limit, load rating, or capacity.
- Do not use to lift people or loads over people.
- Use only alloy chain and attachments for overhead lifting.
- Read and follow all instructions.

COFFING® HOISTS

Coffing Hoists • Country Club Road • P.O. Box 779
Wadesboro, North Carolina 28170 USA
Tel: 800.477.5003 • **Fax:** 800.374.6853 • 704.694.6829
www.coffinghoists.com