



**VESTIL MANUFACTURING CORP.**  
 2999 North Wayne Street, P.O. Box 507, Angola, IN 46703  
 Telephone: (260) 665-7586 -or- Toll Free (800) 348-0868  
 Fax: (260) 665-1339  
 www.vestilmfg.com e-mail: [sales@vestil.com](mailto:sales@vestil.com)

## JIB-FM Series Floor Mounted Jib Cranes



### Receiving Instructions

After delivery, remove the packaging from the product. Inspect the product closely to determine whether it sustained damage during transport. If damage is discovered, record a complete description of it on the bill of lading. If the product is undamaged, discard the packaging.

**NOTE:** The end-user is solely responsible for confirming that product design, use, and maintenance comply with laws, regulations, codes, and mandatory standards applied where the product is used.

### Technical Service & Replacement Parts

For answers to questions not addressed in these instructions and to order replacement parts, labels, and accessories, call our Technical Service and Parts Department at (260) 665-7586. The department can also be contacted online at [http://www.vestilmfg.com/parts\\_info.htm](http://www.vestilmfg.com/parts_info.htm).

### Electronic Copies of Instruction Manuals

Additional copies of this instruction manual may be downloaded from <https://www.vestil.com/page-manuals.php>.

### Table of Contents

	<b>Page</b>
Specifications.....	2
Signal Words.....	2
Safety Instructions.....	3
FIGS. 1-5: Exploded Views and Bills of Materials.....	3 ; 4; 5
Assembling the Crane.....	6 - 8
Function Tests.....	8
Using the Crane.....	8 - 9
Record of Satisfactory Condition.....	9
National Standards.....	9
Inspections and Maintenance.....	10
Labeling Diagram.....	11
Limited Warranty.....	12

## SPECIFICATIONS

Dimensions, net weight, and capacity information for each JIB-FM-series crane are provided in the following diagram and table. However, product design updates could change the specifications of the updated model, particularly its dimensions and net weight. Vestil encourages you to acquire the latest specifications for your product. Specifications documents for JIB-FM-series cranes can be accessed through Vestil's website. To access the appropriate specifications document, navigate to this webpage: <https://www.vestil.com/product.php?FID=529>. Scroll to the *Product Specifications Table* section of the webpage. Then, scroll down to the entry for the model you purchased and click the button in the column titled *PDFs* that looks like a pencil inside a box. A PDF file will open. This file is the specifications document. Print a copy of the document and keep it with a hardcopy of this manual.

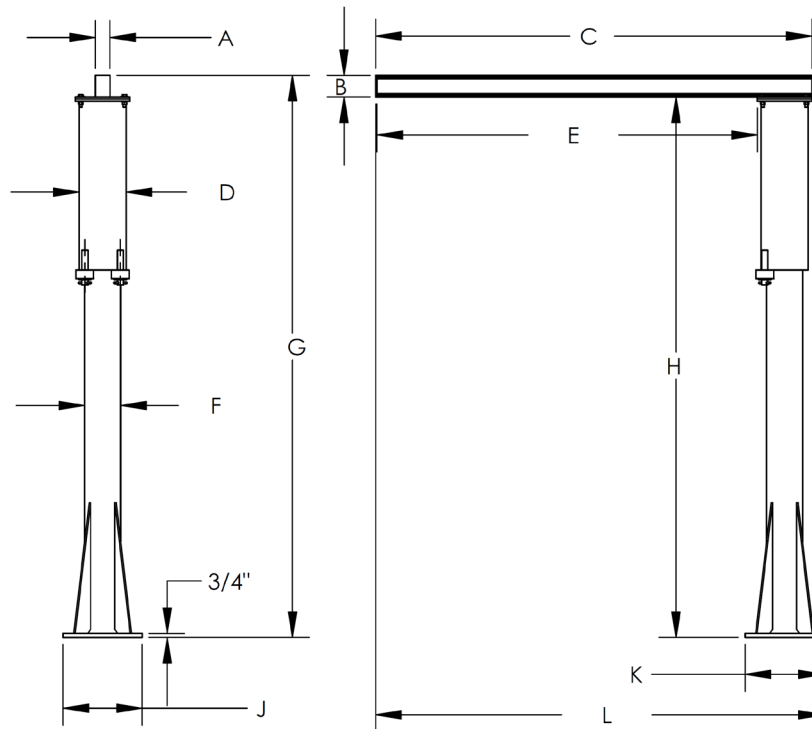

Model	A	B	C	D	E	F	G	H	J	K	L	Capacity	Net wt.
JIB-FM-3	2 <sup>11</sup> / <sub>16</sub> "	4"	80"	8 <sup>5</sup> / <sub>8</sub> "	69 <sup>3</sup> / <sub>4</sub> "	6 <sup>5</sup> / <sub>8</sub> "	103 <sup>1</sup> / <sub>4</sub> "	99 <sup>1</sup> / <sub>4</sub> "	14 <sup>1</sup> / <sub>2</sub> "	14 <sup>1</sup> / <sub>2</sub> "	82 <sup>1</sup> / <sub>4</sub> "	300 lb.	382 lb.
JIB-FM-6	4"	6"	80"	8 <sup>5</sup> / <sub>8</sub> "	69 <sup>3</sup> / <sub>4</sub> "	6 <sup>5</sup> / <sub>8</sub> "	105 <sup>1</sup> / <sub>4</sub> "	99 <sup>1</sup> / <sub>4</sub> "	14 <sup>1</sup> / <sub>2</sub> "	14 <sup>1</sup> / <sub>2</sub> "	82 <sup>1</sup> / <sub>4</sub> "	600 lb.	412 lb.
JIB-FM-10	4"	6"	80"	10 <sup>3</sup> / <sub>4</sub> "	67 <sup>3</sup> / <sub>4</sub> "	8 <sup>5</sup> / <sub>8</sub> "	105 <sup>1</sup> / <sub>2</sub> "	99 <sup>1</sup> / <sub>2</sub> "	17"	17"	82 <sup>1</sup> / <sub>4</sub> "	1,000 lb.	563 lb.
JIB-FM-20	4"	10 <sup>1</sup> / <sub>8</sub> "	80"	10 <sup>3</sup> / <sub>4</sub> "	67 <sup>3</sup> / <sub>4</sub> "	8 <sup>5</sup> / <sub>8</sub> "	109 <sup>5</sup> / <sub>8</sub> "	99 <sup>1</sup> / <sub>2</sub> "	17"	17"	82 <sup>1</sup> / <sub>4</sub> "	2,000 lb.	596 lb.
JIB-FM-40	6 <sup>1</sup> / <sub>2</sub> "	12 <sup>1</sup> / <sub>4</sub> "	80 <sup>3</sup> / <sub>8</sub> "	12"	66 <sup>1</sup> / <sub>8</sub> "	10 <sup>3</sup> / <sub>4</sub> "	111 <sup>1</sup> / <sub>2</sub> "	99 <sup>1</sup> / <sub>2</sub> "	24"	24"	83 <sup>7</sup> / <sub>8</sub> "	4,000 lb.	765 lb.

## SIGNAL WORDS

SIGNAL WORDS appear in this manual to draw the reader's attention to important safety-related messages. The following are signal words used in this manual and their definitions.

<b>⚠ DANGER</b>	Identifies a hazardous situation which, if not avoided, <b>WILL</b> result in <b>DEATH</b> or <b>SERIOUS INJURY</b> . Use of this signal word is limited to the most extreme situations.
<b>⚠ WARNING</b>	Identifies a hazardous situation which, if not avoided, <b>COULD</b> result in <b>DEATH</b> or <b>SERIOUS INJURY</b> .
<b>⚠ CAUTION</b>	Indicates a hazardous situation which, if not avoided, <b>COULD</b> result in <b>MINOR</b> or <b>MODERATE</b> injury.
<b>NOTICE</b>	Identifies practices likely to result in product/property damage, such as operation that might damage the product.

## SAFETY INSTRUCTIONS

Study the entire manual before using this crane. We recommend that a copy of the manual be stored on/attached to the crane at all times. Read the manual to refresh your understanding of the safe operation, inspection or maintenance procedures whenever necessary.

### **⚠ DANGER**

DO not install or use the crane in areas where it will contact electrified wires. Electrocutation might occur if the crane, hoist, or load, etc. contacts electrified wires.

### **⚠ WARNING**

Improper or careless operation might result in serious personal injuries.

- ALWAYS apply operation, inspection, and maintenance recommendations in 29 CFR 1910.179. Contact the occupational safety and health institution of the state where the crane is used for requirements applied to jib cranes.
- DO NOT use a damaged or malfunctioning jib! Restore the crane to satisfactory condition before returning it to service.
- DO NOT attempt to lift a load that weighs more than the capacity of your crane. Capacity information for each JIB-FM model crane is provided in the [SPECIFICATIONS](#) table on p. 2. Capacity information also appears in the [LABELING DIAGRAM](#) section of this manual on p. 11, as well as on capacity labels applied to the crane. The weights of the load, hoist, trolley, rigging, and all other equipment attached to the jib must be added together to determine the net weight applied to the jib. The net weight must never exceed the capacity.
- Always perform the [FUNCTION TESTS](#) on p. 8 before each use.
- Inform all persons in the area that you are going to use the crane; instruct them to stay clear of the device and the supported load during operation.
- Keep clear of suspended loads. DO NOT put any part of your body under a suspended load. DO NOT stand beneath, or travel under, the crane if a load is suspended. DO NOT permit any person to stand beneath or travel
- DO NOT lift people with the crane. DO NOT lift loads over people. DO NOT climb on the load or the crane.
- DO NOT operate manual motions with other than manual power.
- ALWAYS load the jib as recommended on p. 8. Failure to properly position a load might cause the load to swing when it is lifted. Load swing might result in serious injury.
- DO NOT use the crane if any label is unreadable, damaged, or missing. See [LABELING DIAGRAM](#) on p. 11. Contact Vestil for replacement labels.
- DO NOT modify the crane! Modifications automatically void the [LIMITED WARRANTY](#) on p. 12 and might make the crane unsafe to use.

**FIG. 1:** JIB-FM-3 EXPLODED VIEW AND BILL OF MATERIALS

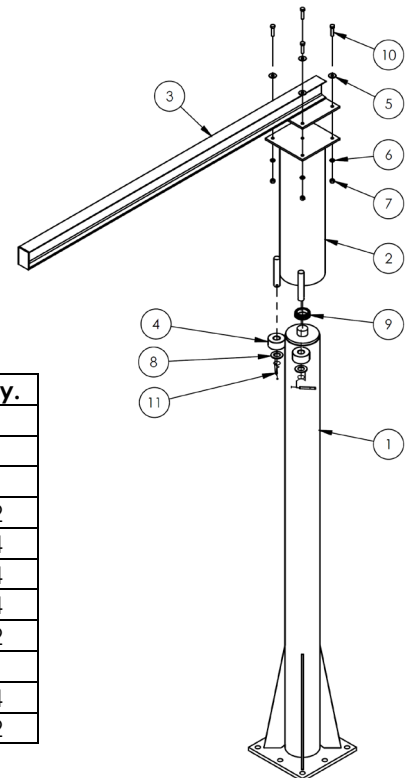

Item	Part No.	Description	Qty.
1	28-514-050	Weldment, floor mount subassembly ("Mast")	1
2	28-514-044	Weldment, pivot subassembly ("Socket")	1
3	28-514-048	Weldment, I-beam subassembly ("Boom")	1
4	05-527-300	Roller, assembly	2
5	33012	Flat washer, low carbon, zinc finish, 1/2"	4
6	33626	Lock washer, zinc plated, 1/2"	4
7	36310	1/2"-13 UNC grade 5, hex nut, zinc plated	4
8	33098	1 1/8" SAE flat washer, zinc-plated	2
9	28-110-001-001	Inner bearing	1
10	13211	1/2" -13x2" HHCS #5, zinc plated bolt	4
11	64319	Pin, spring, 3/8" x 3"	2

**FIG. 2: JIB-FM-6 EXPLODED VIEW AND BILL OF MATERIALS**

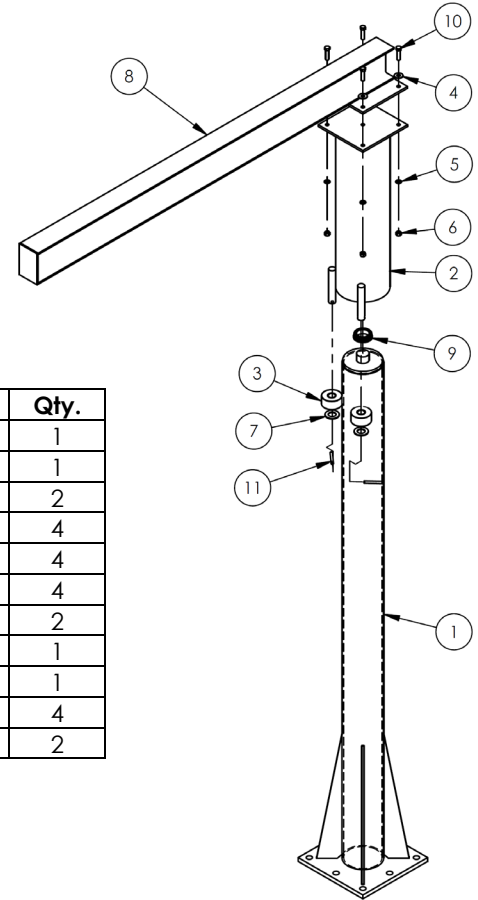

Item	Part No.	Description	Qty.
1	28-514-050	Weldment, floor mount subassembly ("Mast")	1
2	28-514-044	Weldment, pivot subassembly ("Socket")	1
3	05-527-300	Roller, assembly	2
4	33012	Flat washer, low carbon, zinc finish, 1/2"	4
5	33626	Lock washer, zinc plated, 1/2"	4
6	36310	1/2"-13 UNC grade 5, hex nut, zinc plated	4
7	33098	1 1/8" SAE flat washer, zinc-plated	2
8	28-514-049	Weldment, I-beam subassembly ("Boom")	1
9	28-110-001-001	Inner bearing	1
10	13211	1/2" -13x2" HHCS #5, zinc plated bolt	4
11	64319	Pin, spring, 3/8" x 3"	2

**FIG. 3: JIB-FM-10 EXPLODED VIEW AND BILL OF MATERIALS**

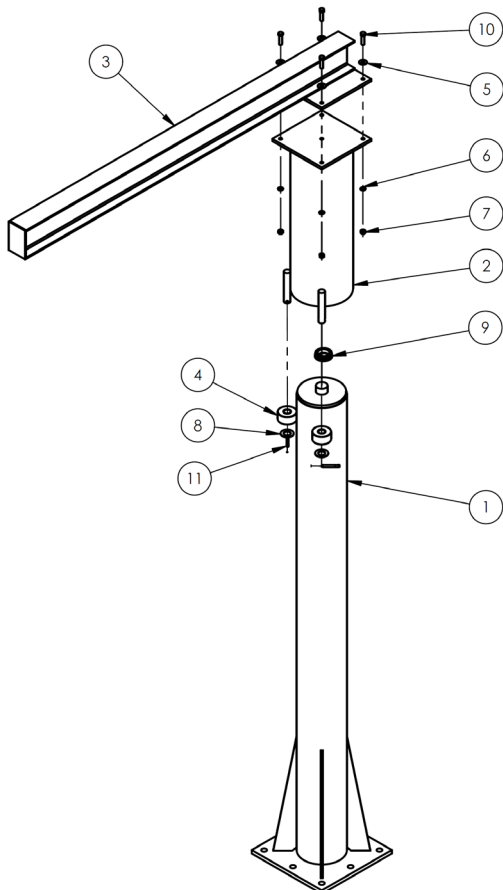

Item	Part No.	Description	Qty.
1	28-514-047	Weldment, floor mount subassembly ("Mast")	1
2	28-514-045	Weldment, pivot subassembly ("Socket")	1
3	28-514-166	Weldment, I-beam subassembly ("Boom")	1
4	05-527-300	Roller, assembly	2
5	33012	Flat washer, low carbon, zinc finish, 1/2"	4
6	33626	Lock washer, zinc plated, 1/2"	4
7	36310	1/2"-13 UNC grade 5, hex nut, zinc plated	4
8	33098	1 1/8" SAE flat washer, zinc-plated	2
9	28-110-001-001	Inner bearing	1
10	13211	1/2" -13x2" HHCS #5, zinc plated bolt	4
11	64319	Pin, spring, 3/8" x 3"	2

**FIG. 4:** JIB-FM-20 EXPLODED VIEW AND BILL OF MATERIALS

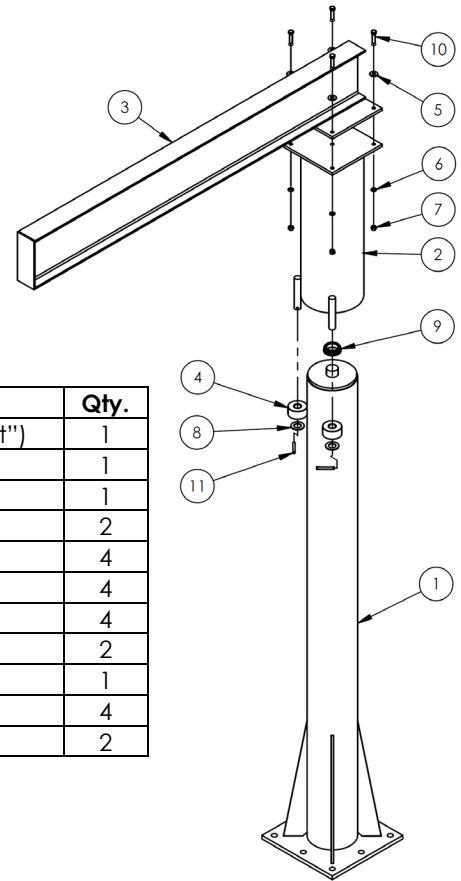

Item No.	Part No.	Description	Qty.
1	28-514-047	Weldment, floor mount subassembly ("Mast")	1
2	28-514-045	Weldment, pivot subassembly ("Socket")	1
3	28-514-046	Weldment, I-beam subassembly ("Boom")	1
4	05-527-300	Roller, assembly	2
5	33012	Flat washer, low carbon, zinc finish, 1/2"	4
6	33626	Lock washer, zinc plated, 1/2"	4
7	36310	1/2"-13 UNC grade 5, hex nut, zinc plated	4
8	33098	1 1/8" SAE flat washer, zinc-plated	2
9	28-110-001-001	Inner bearing	1
10	13211	1/2" -13x2" HHCS #5, zinc plated bolt	4
11	64319	Pin, spring, 3/8" x 3"	2

**FIG. 5:** JIB-FM-40 EXPLODED VIEW AND BILL OF MATERIALS

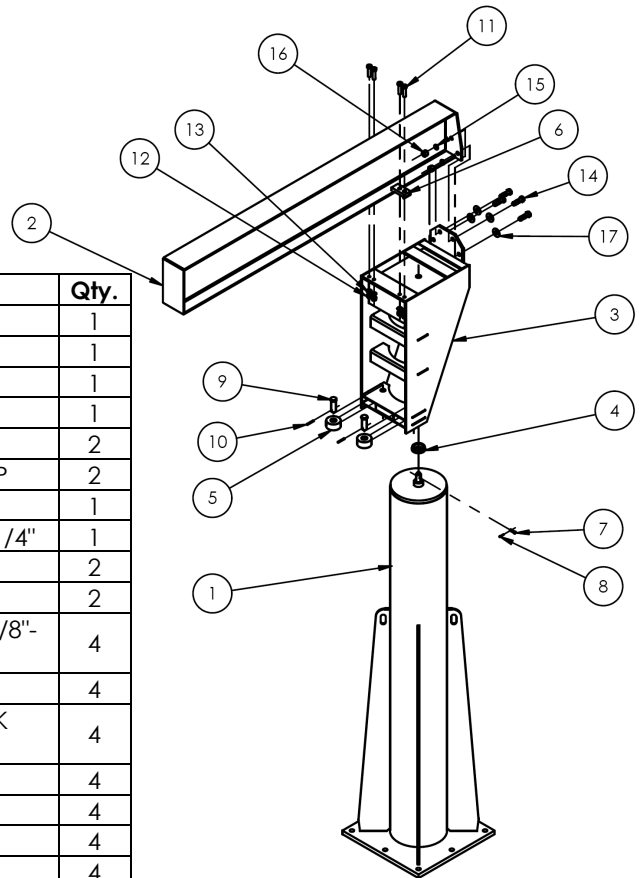

Item No.	Part No.	Description	Qty.
1	28-514-299	WELDMENT, PIVOT PIPE	1
2	28-514-301	WELDMENT, FRAME, BEAM	1
3	28-514-300	WELDMENT, FRAME, UPPER	1
4	28-110-001-001	INNER BEARING	1
5	05-527-300	ROLLER, ASSEMBLY	2
6	28-516-081	WELDMENT, BRACKET, BEAM CLAMP	2
7	28-112-049	PIN, CLEVIS, 3/8" DIA.	1
8	65077	COTTER PIN, ZINC PLATED, 1/8" X 1-1/4"	1
9	28-112-050	PIN, CLEVIS, 1 1/8" DIA.	2
10	64255	Ø0.25 x 2 LG SPRING PIN	2
11	12313	HEX BOLT, GRADE 5, PLAIN FINISH, 5/8"-11 x 2 1/2"	4
12	36114	HEX NUT Z-PLATED, Ø5/8 - 11 UNC	4
13	33630	5/8" ZINC FINISH MEDIUM SPLIT LOCK WASHER	4
14	13363	3/4-10 x 2 1/2 HHCS #5 Z PLATED	4
15	33632	3/4 lock washer	4
16	36116	3/4-10 HEX NUT	4
17	33018	USS FLAT WASHER, Z PLATED, Ø 3/4"	4

### ASSEMBLING THE CRANE

Numbers in parentheses correspond to part numbers in the [EXPLODED VIEWS](#) on pages 3, 4, and 5.

**Step 1:** Create a foundation with embedded reinforcing rods. The necessary minimum foundation requirements for each JIB-FM model crane are provided in the diagrams and table below. When the foundation is adequately cured, install 7/8" jam nuts onto the anchor bolts (eight (8) total). Wind them to the surface of the foundation. Level across the jam nuts by raising/lowering them as necessary to make all of the nuts level. Create a mortar pedestal with grout, e.g. Morta Mix, inside the perimeter formed by the jam nuts. See [OVERHEAD VIEW OF FOUNDATION](#) diagram below. The top of the grout pedestal should be level with the tops of the jam nuts.

**Step 2:** Set the mast on the foundation. Align the bolt holes in the mounting plate with the anchor bolts and carefully lower the mast onto the leveling nuts. Install 7/8" lock nuts on the anchor bolts but leave them loose. Plumb the mast in 90° increments: Check the vertical levelness of the mast at 4 locations equally spaced around the circumference of the mast. Adjust the leveling nuts as necessary to fine tune mast levelness; then tighten the lock nuts against the mounting plate.

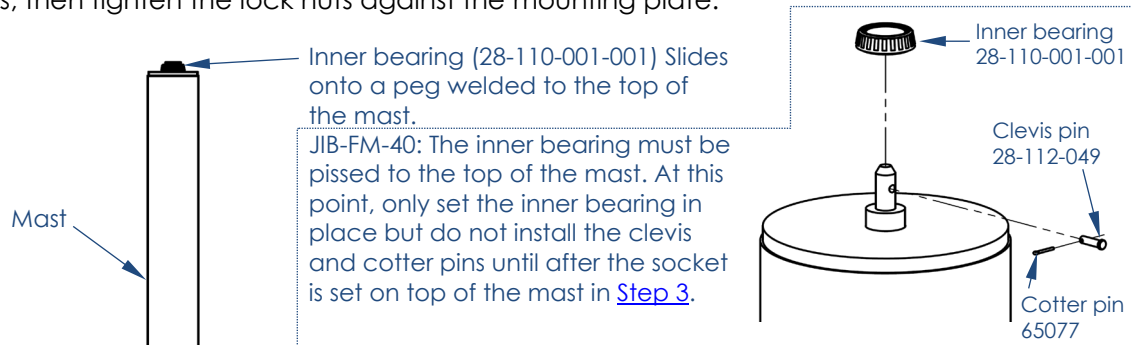

7/8" anchor bolts with J hook (only one shown in diagram; 8 required). Threaded ends of anchor bolts must project ~5" above the surface of the foundation. Bolts must be embedded to depth "B" in foundation.

Model	A	B	C	D
JIB-FM-3	18"	15"	42"	14 1/2"
JIB-FM-6	24"	19"	46"	14 1/2"
JIB-FM-10	30"	23"	50"	17"
JIB-FM-20	30"	23"	60"	17"
JIB-FM-40	48"	41"	72"	24"

Overhead View of Foundation

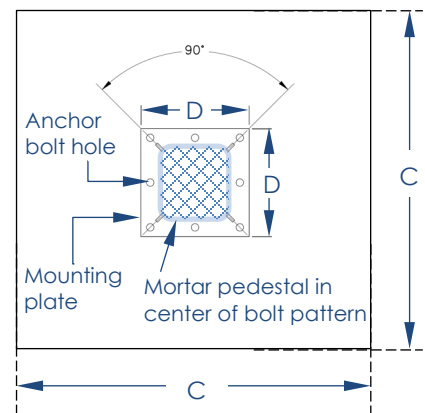

**Step 3:** Install the roller assemblies on the roller pegs as shown below. Liberally grease the thrust bearing inside the socket. Then, install the socket over the top of the mast. Make sure that the inner bearing (28-110-001-001) seats within the thrust bearing inside the socket. Rotate the socket clockwise and counterclockwise. The socket should turn smoothly in both directions.

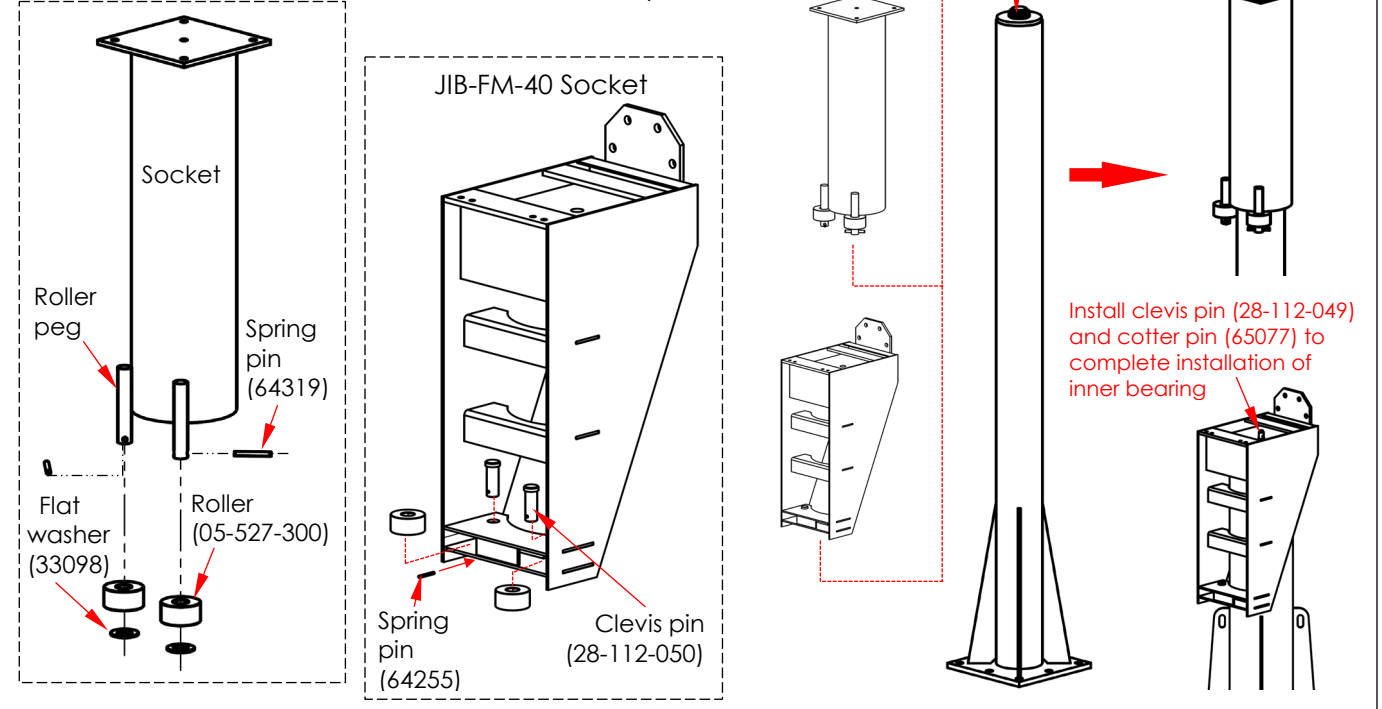

**Step 4:** Attach the boom to the socket using 1/2" hardware as indicated in the diagrams below. Fasten bolts and lock nuts to 94ft·lb. of torque. Fill the remaining space under the mounting plate with grout. Allow the grout to fully cure before placing the jib in service.

**NOTE:** Instructions for model JIB-FM-40 are provided on the following page.

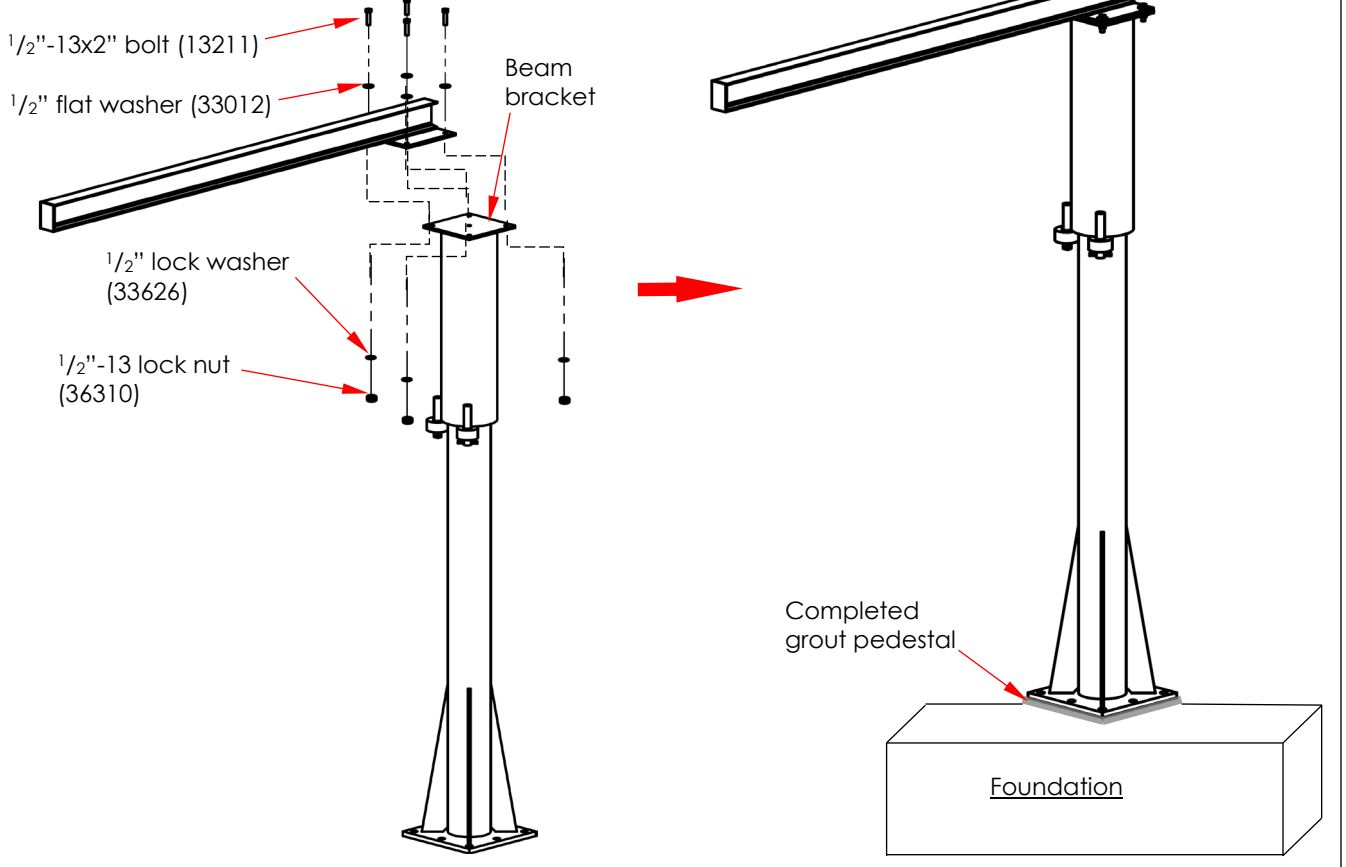

**Step 4 [JIB-FM-40]:** Attach the boom to the rear bracket of the socket using  $\frac{3}{4}$ " hardware as indicated in the diagrams below. Fasten bolts and nuts to 94ft-lb. of torque. Then, apply the beam clamps. Install  $\frac{5}{8}$ " hardware through the clamps and secure them with lock washers and hex nuts. Fasten bolts and nuts to 50-52ft-lb. of torque. The clamps of both sides of the beam should equally overlap the I-beam flange. Fill the remaining space under the mounting plate with grout. Allow the grout to fully cure before placing the jib in service.

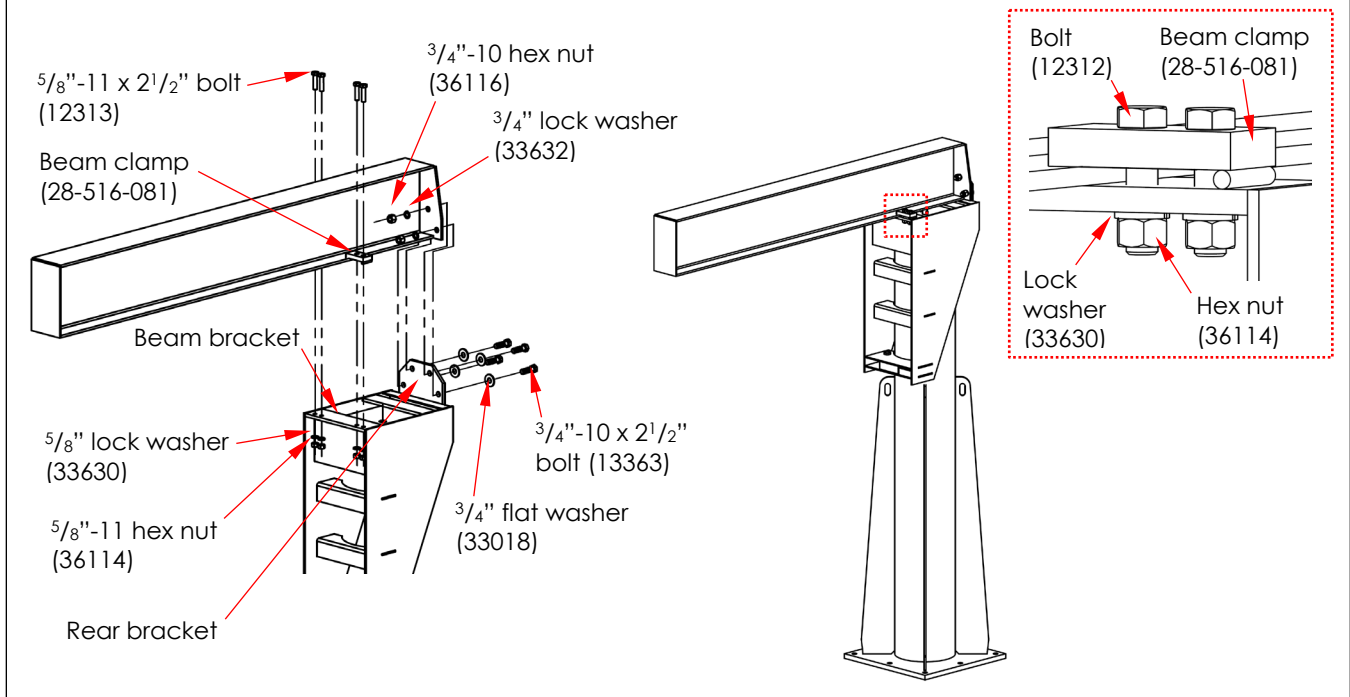

## FUNCTION TESTS

Verify that the jib operates normally by performing the tests below. If an issue is discovered, tag the crane "Out of Service". Restore the crane to normal operating condition before returning it to service.

1. Test the bearing: Rotate the boom in both directions. Make sure that the boom rotates smoothly. Listen for unusual noises while the boom rotates. If the boom wobbles or is unusually noisy, remove the boom and socket from the mast. Grease the bearing inside the socket. Reinstall the boom and socket on top of the mast. If lubrication does not resolve the problem, the bearing might need to be replaced. Contact the factory to discuss the problem and to order replacement parts.
2. Test the hoist and trolley according to the manufacturers' instructions.

## USING THE CRANE

Before using the crane for the first time, perform a [BEFORE AND AFTER EACH USE](#) inspection.

### ⚠ WARNING

Serious personal injury or death could result from improper use.

- Only qualified, designated crane operators should use this device. The operating instructions in this manual *supplement* safe (crane and hoist) operation techniques learned during your training program. ALWAYS apply those techniques and conform to OSHA crane operation standards (29 CFR 1910.179).
- Instruct all persons to remain at a safe distance during operation. All personnel not using the crane should remain outside the operating area during use.
- Tag the crane "Out of service" and notify your maintenance personnel if: 1) you observe any damage to the anchor bolts or the foundation especially the concrete around the anchor bolts; 2) hear unusual noise during use; 3) see warps, cracks, etc. of the boom, the mounting plate (base of the mast), the socket, or the load hook or chain/cable.



Proper load lifting

Always follow the instructions provided with your hoist and trolley.

Position the trolley and hoist directly above the load. Proper positioning is diagrammed below.

Proper load centering beneath hoist and trolley

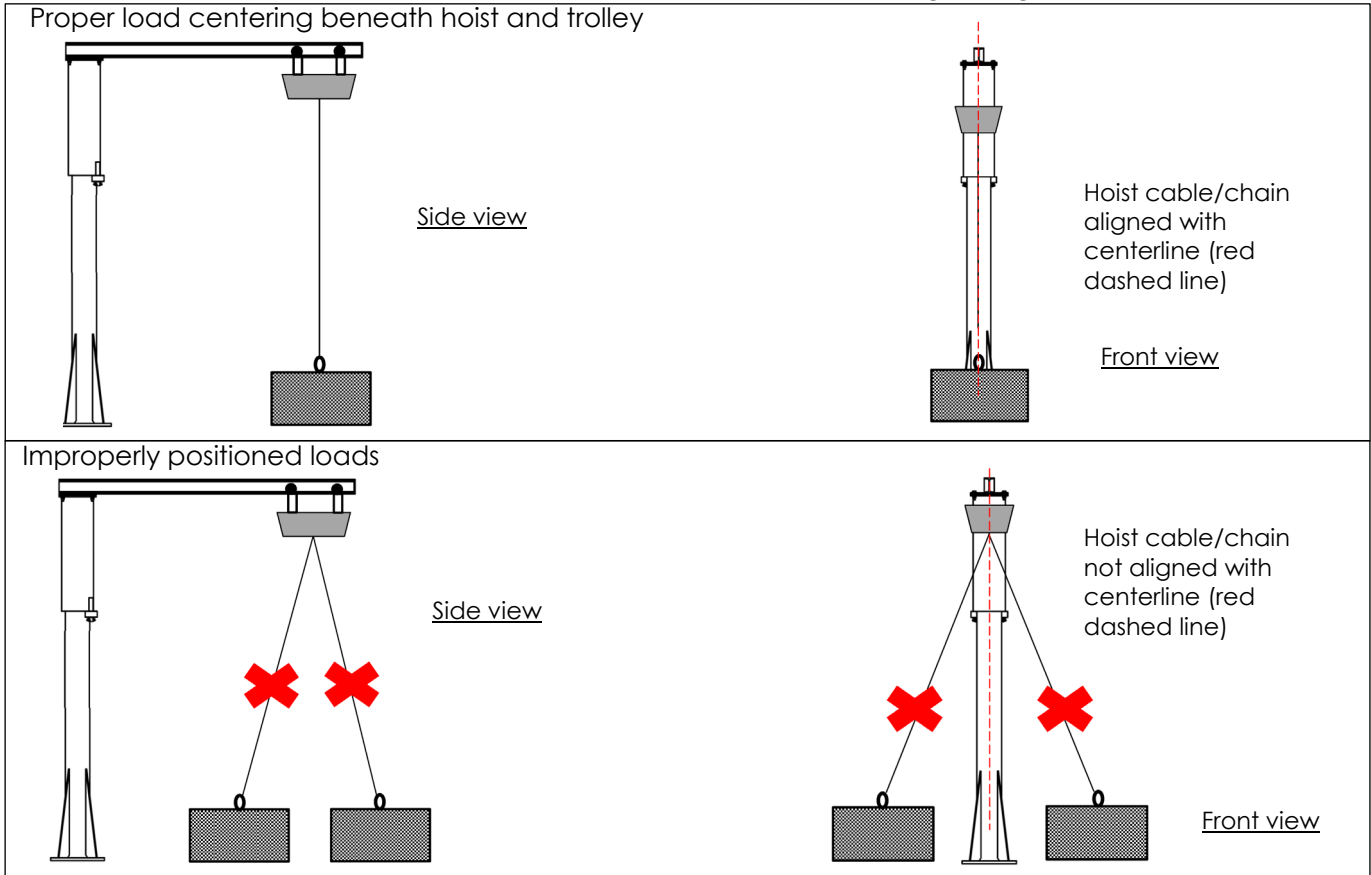

Connect the load to the hoist chain/cable, using appropriate rigging. Then, raise the load only as high as necessary. To rotate the boom, slowly direct the load to the desired location. Once the boom and hoist are properly centered above the work location, lower the load and disconnect it from the hoist.

**RECORD OF SATISFACTORY CONDITION (THE “RECORD”)**

Thoroughly inspect the crane after assembling it and before putting it into service. Record the condition and appearance of each of the frame members (boom, mast, and mast socket), the rollers, and all fasteners (bolts, nuts, etc.). Thoroughly photograph the crane from multiple angles. Include close range photographs of the rollers, all labeling, and all boom connections/fasteners. Also photograph the foundation, paying particular attention to the area immediately surrounding the base of the mast. Add the photographs to the record. Collect all photographs and writings in a single file. This file is a record of the crane in satisfactory condition. Compare the results of all [INSPECTIONS](#) to this RECORD to determine whether the crane is in satisfactory condition. Do not use the crane unless it is in satisfactory condition. Purely cosmetic changes, like damaged paint or powdercoat, are not changes from satisfactory condition. However, touchup paint should be applied as soon as damage occurs.

**NATIONAL STANDARDS**

This product is a floor mounted jib crane. [ASME standard B30.17](#) (the “Standard”) applies to jib cranes. You *should* acquire a copy of the latest version of the standard. Follow all use and maintenance/care instructions provided in the Standard as well as all other provisions for jib crane owners and users. If any content in this manual is inconsistent with a recommendation or mandatory provision in the Standard, apply the provision from the Standard. Vestil encourages you to immediately contact [TECHNICAL SERVICE](#) to report inconsistencies.

## INSPECTIONS AND MAINTENANCE

NOTE: Inspection procedures are included in the most current revision of ASME B30.17. As stated above in the [NATIONAL STANDARDS](#) section, Vestil recommends that you acquire a copy of the most recent revision of this standard. Apply all use and maintenance/care instructions in the standard. Vestil also recommends that you contact your local occupational health and safety authority to determine if any laws, regulations, codes, ordinances, etc. apply inspection requirements where the crane is used.

Inspections and all necessary repairs should be performed by qualified persons. Compare the results of each inspection to the [RECORD OF SATISFACTORY CONDITION](#). Do not use the crane unless every part is in satisfactory condition. **DON'T GUESS! If you have any questions about the condition of your crane, contact the [TECHNICAL SERVICE](#) department.** The phone number is provided on the cover page of this manual. Never make temporary repairs of damaged or missing parts. Only use manufacturer-approved replacement parts to restore the crane to satisfactory condition.

A. **Before and after each use** (including first use), unload the crane and inspect the following components:

- 1) **I-Beam/Boom** – Examine the beam, especially the lower flanges, welds, and regions around fasteners, for bends, cracks, rusting/corrosion, and other forms of damage.
- 2) **Beam Clamps and Beam Clamp Fasteners** – Clamp connections are shown in [Step 4 on p. 8](#). Verify that all lock washers are fully compressed. The clamps of both sides of the beam should equally overlap the I-beam flange.
- 3) **Beam Bracket and Rear Bracket** – Look for cracks, elongations around bolt holes, warps, bends, etc.
- 4) **Foundation and Foundation/Anchor Bolts** – Examine the foundation, particularly around the base of the crane, for cracks, pitting, broken concrete, and other forms of damage. Inspect all anchoring hardware (bolts, nuts, washers). Look for rusting/corrosion. Make sure that the mast is securely anchored (i.e. does not wobble) to the foundation. All connections must be solid. Tighten loose nuts.
- 5) **Socket, Rollers and Pins, Thrust Bearing, and Inner Bearing** – Check all rollers, clevis pins, and cotter pins. All clevis pins must be secured in place with cotter/spring pins. Rotate the boom. Rollers should smoothly and quietly roll over the surface of the mast. Examine the rollers for cracks, significant wear, and other forms of damage. The socket should not wobble as the boom rotates. Each roller must be evenly worn and undamaged. The socket itself should be rigid and undamaged. Lubricate the inner bearing whenever the boom becomes noisy while rotating or when its resistance to rotation increases. Replace the inner bearing if noise and/or resistance is not improved with lubrication.
- 6) **Boom/I-Beam** – Check the boom and its mounting bracket for structural damage, i.e. severe wear, bending, cracking, etc. Replace the entire boom assembly if structural damage is present.
- 7) **Surface coating** - Apply touch-up paint wherever the finish has been affected.

B. **Monthly inspections** – Unload the crane and inspect the following:

- 1) **Beam Clamps and Beam Clamp Fasteners** – Use a torque wrench to tighten each bolt and nut to 50-52ft·lb. Examine all of the clamps for damage including deformations and cracks. The I-beam flange should be solidly/immovably clamped to the tops of the uprights by the clamps
- 2) **Beam Bracket and Rear Bracket** – Look for cracks, elongations, broken concrete around bolt holes, warps, bends, etc. Make sure that all fasteners are tightened to 94ft·lb.

C. **Once per year**: Perform a load test. Lift a load equal to 125% of its rated load (capacity). Only lift the load high enough to ensure that it is entirely supported by the crane. Transport the load by means of your hoist (or hoist & trolley) the full usable length of the I-beam (dimension E in [SPECIFICATIONS](#) diagram and table on p. 2). Return the test load to the ground. Perform inspections A (Before and after each use) and B (Monthly). **NOTE:** Perform this part C (Load test and a Before & after use inspection) whenever the crane is partially or fully disassembled and reassembled, e.g. after installing replacement parts.

## LABELING DIAGRAM

Label content and location are subject to change so your product might not be labeled exactly as shown. Compare the diagram below to your [RECORD OF SATISFACTORY CONDITION](#). If there are any differences between actual labeling and this diagram, contact [TECHNICAL SERVICE](#). Replace all labels that are damaged, missing, or not easily readable (e.g. faded). To order replacement labels or to inquire whether your unit is properly labeled, contact the technical service and parts department online at [http://www.vestilmfg.com/parts\\_info.htm](http://www.vestilmfg.com/parts_info.htm) or by calling (260) 665-7586 and asking for the Parts Department.

### A: Label 391 (both sides of jib) – Capacity

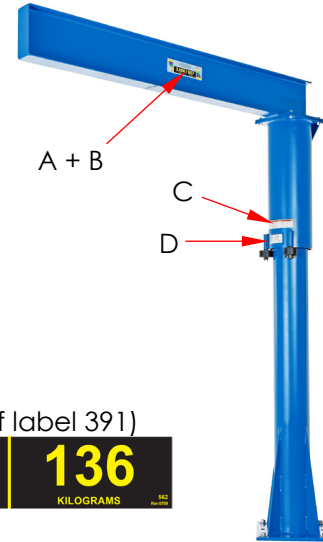
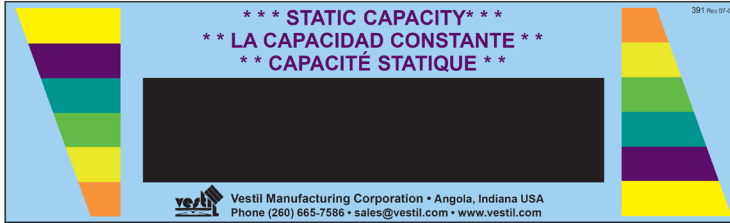

### B: Label 560, 561, or 562 (both sides of jib; applied to black rectangle of label 391)



### C: Label 586 (on other side of jib) – Hazards of use

⚠ WARNING	⚠ ADVERTENCIA	⚠ AVERTISSEMENT
<ul style="list-style-type: none"> <li>• DO NOT exceed rated capacity</li> <li>• LOWER LOAD before moving to avoid load swing</li> <li>• NEVER STAND under, beside or in front of load</li> <li>• USE on hard level surface</li> <li>• INSPECT connections before using</li> <li>• READ manual before use</li> </ul>	<ul style="list-style-type: none"> <li>• No exceda la capacidad tasada</li> <li>• Descienda la carga antes de mover para evitar que la carga se balancee</li> <li>• Nunca se situe debajo, al lado o delante de la carga</li> <li>• Use en una superficie a nivel dura</li> <li>• Inspeccione las conexiones antes del uso</li> <li>• Lea el manual antes del uso</li> </ul>	<ul style="list-style-type: none"> <li>• NE PAS DÉPASSER la capacité nominale</li> <li>• DESCENDRE la charge avant de la transporter pour éviter la giration</li> <li>• JAMAIS vous mettre sous, à côté de ou devant une charge</li> <li>• UTILISER sur un sol plat et dur</li> <li>• INSPECTER les connexions avant utilisation</li> <li>• LIRE le guide avant utilisation</li> </ul>

586 rev 1210

### D: Label 1153 – Product data label.

MODEL / MODÉLO / MODÈLE _____
WEIGHT / PESO / MASS _____
CAPACITY / CAPACIDAD / CAPACITÉ _____
SERIAL / SERIE / SÉRIE _____
UNITS: 2.2 lb. = 1kg      1" (or 1in.) = 2.54cm <b>1153</b>



## LIMITED WARRANTY

Vestil Manufacturing Corporation ("Vestil") warrants this product to be free of defects in material and workmanship during the warranty period. Our warranty obligation is to provide a replacement for a defective, original part covered by the warranty after we receive a proper request from the Warrantee (you) for warranty service.

### Who may request service?

Only a warrantee may request service. You are a warrantee if you purchased the product from Vestil or from an authorized distributor AND Vestil has been fully paid.

### Definition of "original part"?

An original part is a part used to make the product as shipped to the Warrantee.

### What is a "proper request"?

A request for warranty service is proper if Vestil receives: 1) a photocopy of the Customer Invoice that displays the shipping date; AND 2) a written request for warranty service including your name and phone number. Send requests by one of the following methods:

<u>US Mail</u>	<u>Fax</u>	<u>Email</u>
Vestil Manufacturing Corporation 2999 North Wayne Street, PO Box 507 Angola, IN 46703	(260) 665-1339 <u>Phone</u> (260) 665-7586	<a href="mailto:info@vestil.com">info@vestil.com</a> Write "Warranty service request" in the subject field.

In the written request, list the parts believed to be defective and include the address where replacements should be delivered. After Vestil receives your request for warranty service, an authorized representative will contact you to determine whether your claim is covered by the warranty. Before providing warranty service, Vestil will require you to send the entire product, or just the defective part (or parts), to its facility in Angola, IN.

### What is covered under the warranty?

The warranty covers defects in the following original, dynamic parts: motors, hydraulic pumps, motor controllers, and cylinders. It also covers defects in original parts that wear under normal usage conditions ("wearing parts"), such as bearings, hoses, wheels, seals, brushes, and batteries.

### How long is the warranty period?

The warranty period for original dynamic components is 1 year. For wearing parts, the warranty period is 90 days. Both warranty periods begin on the date Vestil ships the product to the Warrantee. If the product was purchased from an authorized distributor, the periods begin when the distributor ships the product. Vestil may, at its sole discretion, extend a warranty period for products shipped from authorized distributors by up to 30 days to account for shipping time.

### If a defective part is covered by the warranty, what will Vestil do to correct the problem?

Vestil will provide an appropriate replacement for any covered part. An authorized representative of Vestil will contact you to discuss your claim.

### What is not covered by the warranty?

The Warrantee (you) is responsible for paying labor costs and freight costs to return the product to Vestil for warranty service.

### Events that automatically void this Limited Warranty.

- Misuse;
- Negligent assembly, installation, operation or repair;
- Installation/use in corrosive environments;
- Inadequate or improper maintenance;
- Damage sustained during shipping;
- Collisions or other accidents that damage the product;
- Unauthorized modifications: Do not modify the product IN ANY WAY without first receiving written authorization from Vestil.

### Do any other warranties apply to the product?

Vestil Manufacturing Corp. makes no other express warranties. All implied warranties are disclaimed to the extent allowed by law. Any implied warranty not disclaimed is limited in scope to the terms of this Limited Warranty. Vestil makes no warranty or representation that this product complies with any state or local design, performance, or safety code or standard. Noncompliance with any such code or standard is not a defect in material or workmanship.