

VORSPRUNG[®]

Electric Vehicle AC Charging Unit



User Manual

Model: 20137

Thank you for choosing one of our Vorsprung AC charging unit. To help you correctly use, operate, maintain, check and troubleshoot this AC charging unit, please carefully read this User Manual before use, operate according to this User Manual only, and keep safe for future use.

This Unit must only be installed & fitted by a Certified Engineer

Installation must only be performed by a Certified Engineer competent in accordance with the current legislation in force in the geographical location of the installation.

- Advice provided in this manual does not override any legislation.
- If the advice in this manual is not understood, contact the distributor for further advice and/or training before attempting installation/operation of the equipment.

The manufacturer/distributor cannot accept any responsibility for improper installation or any problems arising from improper installation.

NOTE: Damage to the equipment, connected systems or to property caused by improper installation are the responsibility of the engineer.

NOTE: All electrical work must be performed in accordance with the current Electrical Wiring Regulations.

CONTENTS

1- Safety precautions.....	3
2- Introduction.....	3
3- Design specification.....	4
4- Technical Specification.....	5
5- Installation.....	6
6- Using the APP.....	11
7- Guarantee.....	12



The input and output voltage of this equipment is risk high voltage; this will endanger people's life. Please strictly follow all warnings and operating instructions on the machine and in this manual. Never disassemble the outer cover of this machine.

1- Safety Precautions

Installation of this Unit must be Performed by a Certified Engineer

- 1.1. Turn off the power supply prior to and during the installation, to prevent electric shock.
- 1.2. The charging unit's power cable must be firmly connected and well insulated. Loose connection and damages will cause circuit failure, which may cause a fire or casualties in severe cases.
- 1.3. The installation of the charging unit and connection to the power grid must be conducted by a trained, certified professional.
- 1.4. If the unit is dropped at any point prior to installation, it should not be installed until the engineer has inspected the unit to determine whether or not it can safely be installed.
- 1.5. Do not wash or cover the charging unit with any liquid. To clean the charging body, wipe gently with a lightly damp cloth, avoiding the connector area.
- 1.6. Any faults which arise that may impact the safety of the unit should be addressed by a certified engineer. Please do not attempt any repairs yourself.
- 1.7. The charging unit should only be installed by a certified engineer. The seller will not bear any responsibility for any loss caused by uncertified engineers and personnel for any modifications.

2- Introduction

This product is a single-phase AC charging unit, mainly used for AC slow charging of electric vehicles. The design of the product is simple. It provides card swiping and plug and play charging modes, with charging protection function. The principle of industrial design is adopted for the equipment, with the original function of toppling protection to ensure safe operation of the equipment. The protection level of the whole equipment reaches IP55, and it has good dustproofing and waterproofing functions and can be safely operated and maintained outdoors.

2.1. Composition

The charging unit is mainly composed of shell, back cover, main control board, human-computer interface, display module, card swiping module, communication module, fuse, emergency stop switch, charging interface, charging gun line, gun line hanging plate, etc.

2.2. Main Features

- 2.2.1. Modular design, stable and reliable: Modular design principle is adopted for the equipment, with flexible configuration and convenient maintenance.
- 2.2.2. All-round protection and safe operation: It has over-voltage protection, under-voltage protection, overload protection, earth leakage protection, grounding protection, over-temperature protection, low-temperature protection, lightning protection and toppling protection, ensuring safe and reliable operation of the equipment and effectively preventing accidents.
- 2.2.3. Easy to use: Easy to install and use.
- 2.2.4. High protection level: IP55, supporting outdoor harsh environment, not needing to set up additional canopy, etc.
- 2.2.5. Low power consumption: The standby power consumption of the equipment is as low as 3W, energy saving and low consumption.
- 2.2.6. Compatibility: The equipment is a simple home version and can be configured in plug & play operating mode with the software. Only the software needs to be set, while the hardware does not need to be transformed.
- 2.2.7. Structure: Occupying a small space, is lightweight, the equipment is to be installed to a solid wall or to a compatible floor mount.

3- Design Specification



4- Technical Specification

Table-1 Technical Specification of AC charging unit

Name	Single-phase
Maximum output power	7.4KW
Input voltage	AC 220V
Input voltage frequency	50Hz/60Hz
Output voltage	AC 230V
Output current	32A
Efficiency	≥98%
Insulation resistance	≥10MΩ
Power consumption of control module	≤7W
AC & DC Fault Protection	Type A 30mA RCD
Operating ambient temperature	-30°C~+50°C
Earthing Protection	PEN Protection Built In – No Earth Rod Needed
Storage ambient temperature	-40°C~+80°C
Ambient humidity	5% ~95% No frost, no condensation
Altitude	Not more than 2000 meters
Status indication	LED indicator
Screen	4.3-inch LCD color screen
Communication mode	WiFi, Bluetooth
Charging interface	IEC 62196 Type 2
Degree of protection	IP55、IK10
Safety protections	Overvoltage protection, undervoltage protection, grounding protection, lightning protection, leakage protection, flame retardant protection, vercurrent protection.
Cable Length	5.2 meters
Weight	4.2KG

5- Installation

5.1. Parts Included

Please check you have all parts before installation

- 1 x AC Wall Unit Charger
- 1 x User manual for AC Wall Unit Charger
- 1 x Certificate
- 1 x Wall Bracket
- 3 x 30mm rubber plugs
- 3 x KA30 10mm screws

5.2. Site Requirements



- 5.2.1. The charging unit meets the IP55 protection level and can be installed both indoors & outdoors.
- 5.2.2. Please ensure that the ambient temperature is within the range of -30°C~+50°C.
- 5.2.3. The altitude of the installation site shall not be higher than 2000 meters.
- 5.2.4. There should be no vibration, flammables, and explosives near the installation site.
- 5.2.5. The installation site should not be located in low-lying areas or areas prone to water accumulation or flooding.
- 5.2.6. The unit must be installed onto a wall. If there is no wall support, it is recommended to use a special EV floor post for installation and fitting.
- 5.2.7. The unit must be installed vertical, the centre point of the gun base to the horizontal ground should be between 1200~1300mm.

5.3. Preparation for Installation

For the sake of safety, only a Certified Engineer can install and fit the charging unit. Please do not attempt to install it yourself.

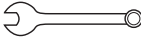
Installation Tools

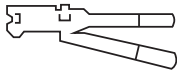
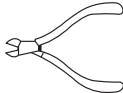
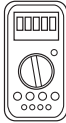
Tool Name	Picture	Main Function
Insulation torque spanner		Fastening the bolts
Combination spanner		Fastening the bolts

Hydraulic tongs		Fastening the bolts
Diagonal pliers		Cutting off the cables
Multi-meter		Checking electrical connection and electrical parameters
Cross screwdriver (PH2×150mm, PH3×250mm)		Fastening the screws
Insulation adjustable spanner		Fastening the bolts

Preparation of Cables

The following cable specifications for charging unit power supply is recommended:

Cable Name	Cable Specification	Length
Power line	Minimum Requirement: single-phase 3-core 6mm ² power cable	Subject to the specific construction length
Circuit breaker	One-phase 40A circuit breaker	

5.4. Installation Process

1) Incoming wiring of charging unit

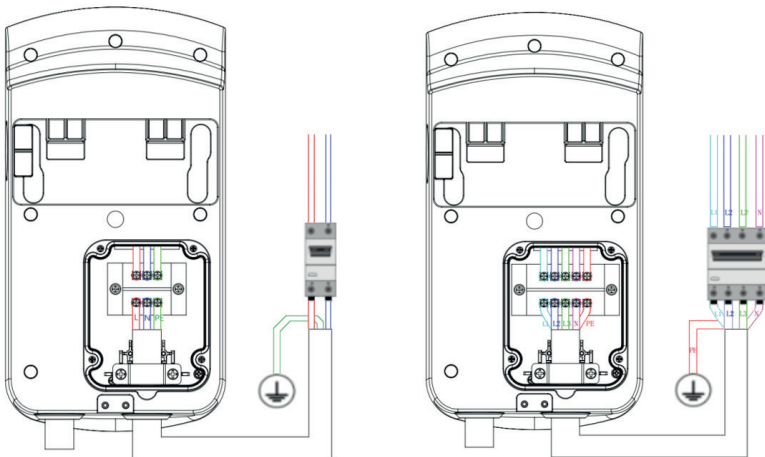

2) Wall Mounting & Fitting

Hang the mounting hole at the back of the equipment onto the fixed screw on the wall from the front and fix it;

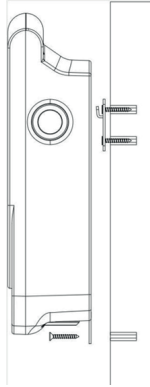

5.5. Before Initial Use

1) Pre-operating inspection

5.5.1. Before starting the AC unit, make sure of the following things:

5.5.2. The AC unit is installed in a convenient location for maintenance and operation.

5.5.3. The AC unit and accessories are properly connected and firmly installed.

5.5.4. The earth leakage circuit breaker at the AC incoming terminal is suitable for the application.

5.5.5. There are no external objects or parts left on top of the AC unit.

5.5.6. Confirm that all the above items meet the requirements before operation.

5.5.7. Close the earth leakage circuit breaker of incoming power line.

5.6. Operating

1) Connecting the Charger: Remove the charging gun from the unit and plug it into the charging port of the electric vehicle. Make sure it's inserted properly for a secure connection.

2) Charging Control: This charger offers two methods of charger control: charging via Smart App and charging via RFID Cards.

Charging via RFID card:

After parking the vehicle, plug in the charging gun and swipe the card on the card reader area on the unit. Keep a distance of at least 2mm between the card and the reader for about 3 seconds, charging will be initiated.

Charging via Smart App:

Control your charger remotely via the Smart App. You can schedule charging for any hour of the day or night. Simply follow the prompts on the App to set up. You also have the option on the App to disable the App and just use the RFID swiping function to control charging.

Please Note – Upon initial installation of the charger it will need to be connected to your Wi-Fi, it will not charge unless it is connected and paired with the App. You can disable this function after the first charge.

2) To Stop Charging: To stop the charging process when the unit is in use, the vehicle owner can: *Swipe the card to stop charging, then remove the charging gun.*

5.7. Troubleshooting

Fault phenomenon	Possible causes	Solution
AC over-voltage	AC input voltage is too high	1- Ask an electrician to test the input voltage of air switch.
		2- If the actual voltage is greater than 264Vac for a short time, wait for the peer-to-peer network to recover to the normal voltage range.
		3- If the actual voltage is greater than 264Vac for a long time, please contact the power supply department.
		4- If the actual voltage is less than 264Vac, please contact Seller;
AC under-voltage	AC input voltage is too low	1- Ask an electrician to test the input voltage of air switch.
		2- If the voltage is lower than 85Vac for a short time, wait for the peer-to-peer network to recover to the normal voltage range.
		3- If the actual voltage is less than 85Vac for a long time, please contact the power supply department.
		4- If the actual voltage is greater than 85Vac, please contact Seller;
AC over-current	AC input current is too high	1- Immediately turn off the leakage/over-current protection switch of the distribution box.
		2- Check whether there is a low-impedance connection between two output lines of AC unit.

AC over-voltage	AC input current is too high	3- After the above problems are eliminated, power on again. If the fault still exists, please contact Seller.
Over-temperature	The interior temperature is greater than 85°C	1- Check the installation environment of AC unit to see whether there is heating equipment or devices nearby, and ensure the ambient temperature is below 60°C.
		2- If the fault can't be eliminated, please contact Seller;
Leakage current exceeds the limit	The leakage current is greater than 30mA	1- Immediately disconnect the leakage/ over-current protection switch of the distribution box.
		2- Check whether the output line of AC unit is damaged or has low-impedance connection to the ground.
		3- After the above problems are eliminated, reset the reset switch of leakage current protector, and power on again. If the fault still exists, please contact Seller;
Leakage current sensor is abnormal	The sensor for detecting the leakage current is abnormal	1- Immediately disconnect the leakage/ over-current protection switch of the distribution box.
		2- Check whether the output line of AC unit is damaged or has low-impedance connection to the ground.
		3- After the above problems are eliminated, power on again. If the fault still exists, please contact Seller;
Ground fault	The input/output grounding is poor or the input L/N connection is reverse	1- Immediately disconnect the leakage/ over-current protection switch of the distribution box.
		2- Check whether the grounding of AC unit input/output line is normal and whether the input L/N is connected according to normal sequence.
		3- After the above problems are eliminated, power on again. If the fault still exists, please contact Seller;

5.8. Troubleshooting of general faults

In case of any abnormality during use, If you still cannot troubleshoot a certain fault, please cut off the power supply of the charging unit and contact our customer service center.

6- Using the APP

From Google play or Apple Store, download either of the following Apps: Tuya Smart or Smart life.



Tuya



Smart Life

- 1- Open the App.
- 2- Select the plus symbol in the upper right corner to automatically discover the device.
- 3- Enable Wifi and Bluetooth permissions.
- 4- Start searching.
- 5- Enter Wifi account and password (you will need to be connected to 2.4GHz Wi-fi).
- 6- Wait for the charging device to be successfully added to the Internet.
- 7- You will then be able to discover the App features.

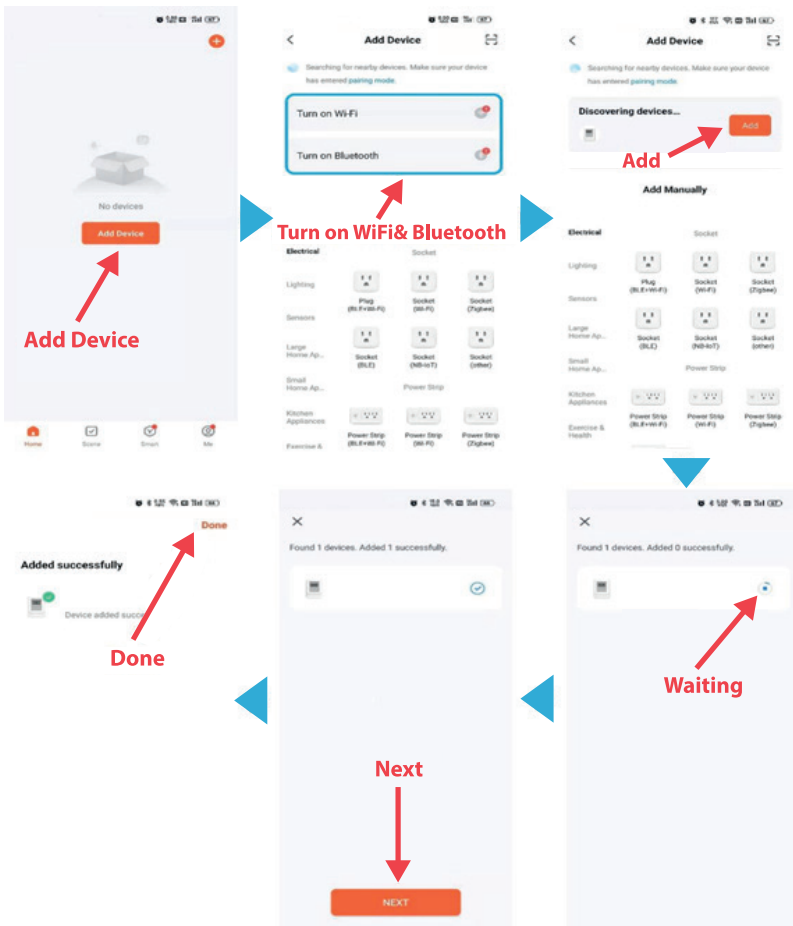

7- Guarantee

Subject to the provisions described below, this product is protected for 12 months from the date of purchase against defects in parts. Any labour cost to the consumer is not and with not be covered.

Prior to returning any defective products to Vorsprung, the end user must report the faulty product to Vorsprung. This can be done via e-mail: info@vorsprungofficial.com. If Vorsprung agrees that the product should be returned, it will Issue a Returns Authorisation Number. This number must be clearly marked on the packaging of the product to be returned. The customer will return the product at their own cost.

Should the product fail to perform as described within the relevant guaranteed period as set out above, it will be repaired or replaced with the same or functionally equivalent product by Vorsprung at its discretion, free of charge, provided the customer:

- 1) Provides Vorsprung with proof of purchase.
- 2) Returns the failed product to Vorsprung with shipping charge prepaid.

Replacement products may be refurbished or contain refurbished materials. If Vorsprung, by its sole determination, is unable to repair or replace the defective product, it will replace or refund the purchase price of the product at their discretion.

The guarantee does not apply and will be null and void if, in judgement to Vorsprung, the product fails due to damage from storage, incorrect Installation, accident, inappropriate use or cleaning of the product, relocation of the product after its first Installation, abuse, misuse, or if It has been used or maintained in a manner not conforming to product manual instructions. Damage or failure caused by foreign matters entering the unit. Damage caused by dismantling the unit by a non-certified EV Engineer. Damage caused by force majeure (such as lightning, high voltage, earthquake, fire, flood, and other natural disasters). Damage caused by water entering the equipment or other solutions due to improper installation & use. Damage caused by using power supply and voltage other than those specified. Has been modified in any way, or has had any serial number or other Identification markings removed or defaced.

Repair by anyone other than a certified engineer will void this guarantee. Proof of installation may be requested.

All defective products should be returned to Vorsprung with shipping charges prepaid.

Should an issue be found with your unit. Vorsprung will return your repaired/replaced unit free-of-charge to any UK address. Should the return address be outside of the UK; return postage will be at Vorsprung's discretion. If the unit is found not to be defective return postage will need to be paid by the customer/sender.

Nothing in this agreement will affect the end consumer's statutory rights. Vorsprung only supply products for domestic, light commercial and private use.

Vorsprung accept no liability to the end consumer for any loss of profit, loss of business, business interruption, loss of business opportunity or time travel incurred.

Electric Vehicle AC Charging Unit

User Manual

Model: 20137

VORSPRUNG[®]