

Joywhale

12V RIDE ON CAR

- Suitable for 3 to 8 years
- Maximum user weight: 66lbs/30kg
- Adult assembly required

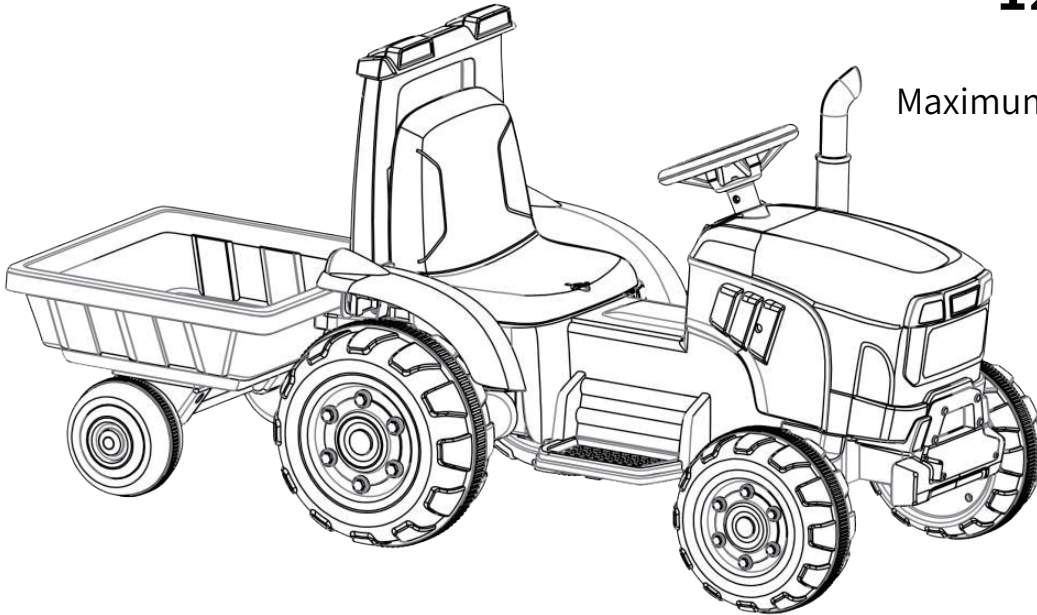



Please install this ride-on car according to the instruction and the installation video on the detail page of your purchased product.

Charge for 4-6 hrs before initial use.

After initial charge, follow the normal recommended charging time.

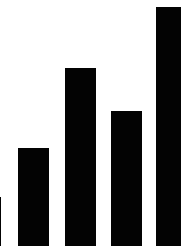
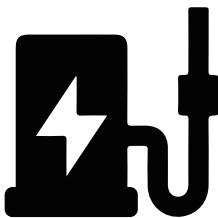

① SAFETY

| | |
|------------------------|---|
| NOTE | For best performance, only use this vehicle on flat and hard surfaces |
| AGE RANGE | 3 to 8 years old |
| WEIGHT CAPACITY | 66LBS (30KG) is the maximum weight for 1 rider |

⚠ WARNING

- This product contains small parts. Keep children away during assembly. Make sure to remove all packaging material and parts from underneath the vehicle body.
- Never open the battery. Batteries contain lead and lead compounds (acids).
- Limbs, hair and clothing can get caught in moving parts. Always wear shoes, keep limbs away from moving parts and do not wear loose clothing while operating this vehicle.
- This vehicle does not have separate braking system. Do not leave a child unattended during operation. Do not use it in a location that may require emergency stop function as this could result in loss of control, which may cause serious injury or death.
- Use of this vehicle near streets, motor vehicles, steps, bodies of water, sloped surfaces, hills, wet areas, flammable vapors, in alleys, at night or in the dark could result in an unexpected accident.
- Use of this vehicle in unsafe conditions such as snow, rain, loose dirt, mud, sand or gravel may result in an unexpected accident such as tipping over and could damage the electrical system or battery.

- Do not operate this vehicle in an unsafe manner. Examples include but are not limited to
 - Pulling the vehicle with another vehicle or similar device
 - Allowing more than one child to ride
 - Pushing the user
 - Traveling at an unsafe speed

WARNING

- Use of a battery or charger other than the supplied rechargeable battery and charger may cause a fire or explosion. Only use the supplied battery and charger.
- Use of the rechargeable battery and charger for any other product may result in overheating, fire or explosion.
- Never use the supplied rechargeable battery and charger with another product.
- Explosive gases are created during charging. Charge the battery in a well ventilated area. Do not charge the battery near heat or flammable materials.
- Contact between the positive and negative terminals may result in fire or explosion. Avoid direct contact between the terminals. Picking up the battery by the wires or charger can cause damage to the battery and may result in a fire. Always pick up the battery by its case or handles.
- Liquids on the battery may cause fire or electric shock. Always keep all liquids away from the battery and keep the battery dry. Contact or exposure to battery leakage (lead acid) may cause serious injury. If contact or exposure occurs immediately call your physician. If the chemical is on the skin or in the eyes, flush with cool water for 15 minutes. If the chemical was swallowed, immediately give the person water or milk. Do not give water or milk if the patient is vomiting or has a decreased level of alertness. Do not induce vomiting.
- Battery posts, terminals and related accessories contain lead and lead compounds (acid).

- Tampering or modifying the electric circuit system may cause a shock, fire or explosion and permanently damage the system. Exposed wiring and circuitry in the charger may cause electric shock. Always keep the charger housing closed.

WARNING

- Never leave a child unattended.
- Always sit in the seat when using this vehicle.
- Keep your hands, hair and clothes away from moving part.
- Always wear shoes when operating this vehicle.
- Children under 3 years of age cannot use the vehicle.
- Only drive on level ground.
- Do not go near swimming pools or other bodies of water, drop-offs or up and down steep inclines.
- Do not drive the vehicle into loose dirt, mud, sand, fine gravel or on wet surfaces.
- Do not drive the vehicle on streets or near cars.

| | |
|-------------------|--------------------------------------|
| Item | DP-TR10 |
| Batteries | 12V 4.5AH |
| Motor | 12V #390 |
| Age | 3-8 years |
| Max Weight | 66LBS (30KG) |
| Dimension | 49.2*22.8*23.6 INCH (125*58*60 CM) |
| Speed | 1.6-2.2 MPH (2.5-3.5 KM/H) |
| Play Time | 1-2 hours/ recharger time 8-12 hours |
| Charger | Output DC 12V |

② TOOLS REQUIRED



2 PERSON
ASSEMBLY



APPROXIMATELY
45 MIN ASSEMBLY



SCREWDRIVER
(BRING YOUR OWN)



M10 WRENCH
(PROVIDED)

M4*10MM
SCREW

1



10 PCS

φ10 GASKET

2



11 PCS

M10 NUTS

3



6 PCS

M4*20MM
SCREW

4



2 PCS

COTTER PIN

5



1 PCS

FRONT WHEEL

A

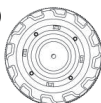

2 PCS

REAR WHEEL

B

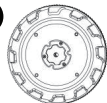

2 PCS

REAR BUCKET
WHEEL

C



2 PCS

FRONT WHEEL
COVER

D



2 PCS

REAR WHEEL
COVER

E



2 PCS

REAR BUCKET
WHEEL COVER

F



2 PCS

TAILSTOCK



1 PCS

REMOTE CONTROL



1 PCS

CHARGER



1 PCS

STEERING LEVER



1 PCS

CAR BUCKET
AXLE



1 PCS

CAR BUCKET
AXLE FIXED SEAT



2 PCS

SEAT



1 SET

CHIMNEY

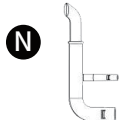

1 PCS

STEERING WHEEL



1 PCS

CAR BUCKET



1 PCS

CAR BUCKET
CONNECTION



1 PCS

BODY CONNECTION

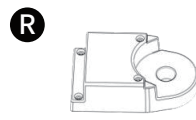

1 PCS

CAR BUCKET
LATCH



1 PCS

REAR AXLE



1 PCS

GEAR BOX (L/R)

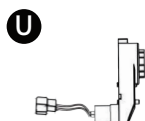

2 PCS

AUDIO CABLE

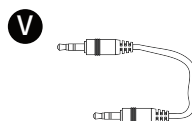

1 PCS

③ PRODUCT ASSEMBLY

Turn over the body so that its body faces up.

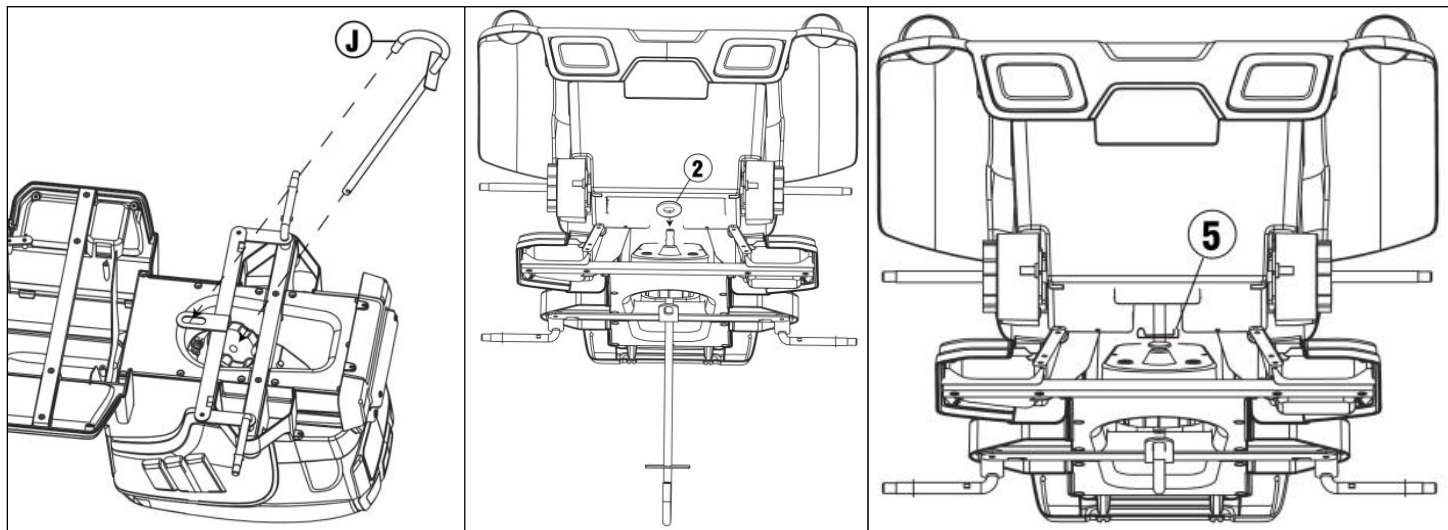

① Fix the steering lever.

- Insert the steering lever into the body hole.
- Insert $\phi 10$ washer on steering lever.
- After the steering lever is installed in place, insert the cotter pin to bend and fix it.

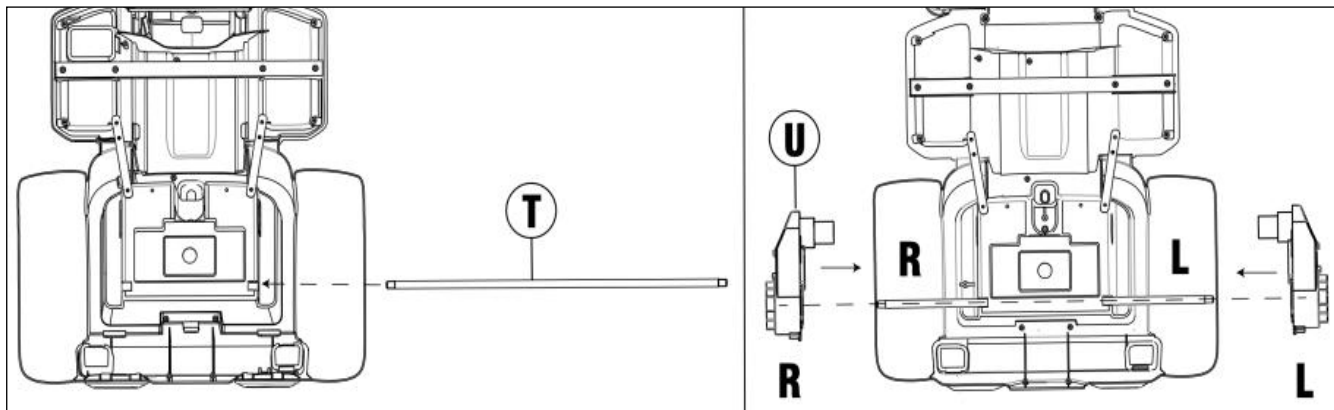

Ⓣ Fix the rear axle.

- Insert the rear axle into the car.

Ⓤ Fix the gear box (L/R)

- Put the gear box into the rear axle, and clip the motor and motor wire into the body slot.
(Note: the gear box is distinguished from the left and right)

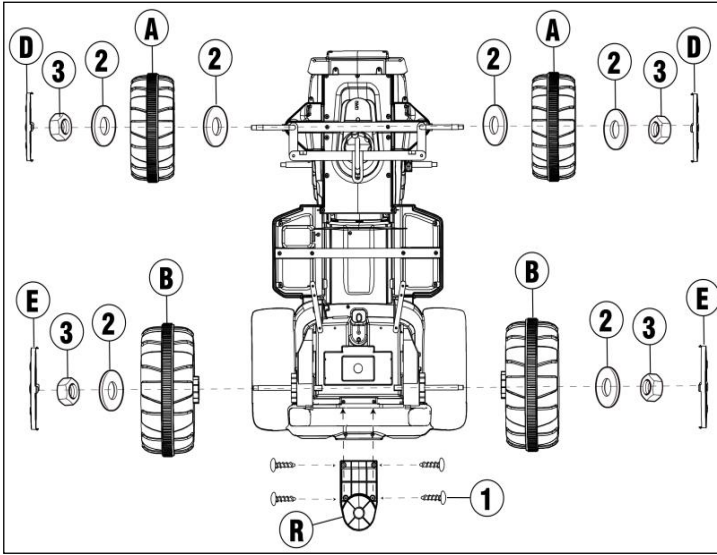

- Put the gaskets, front wheel, gaskets and nut into the front axle in turn.
- Fix the nut with the M10 wrench and then attach the front wheel cover to the wheel.
- Place the rear wheel, gaskets, and nut on the rear axle in turn.
- Fix the nut with the M10 wrench and then attach the rear wheel cover to the wheel.
- Clip the body connection into the body and fix it with M4*10mm screws.

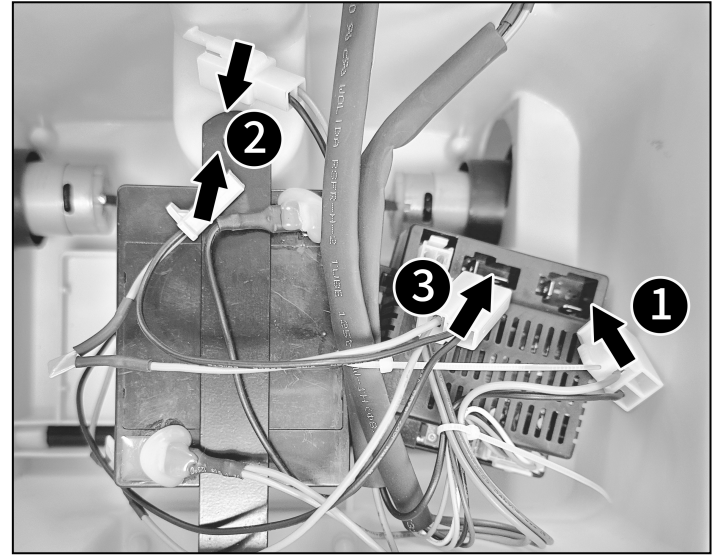

Turn over the body

- ① Find out the main power line under the seat, insert the plug-in of the power line into the corresponding socket of the receiver.
- ② Connect one end of the right drive motor line with the left drive motor line.
- ③ Insert the other plug-in into the socket of the receiver.

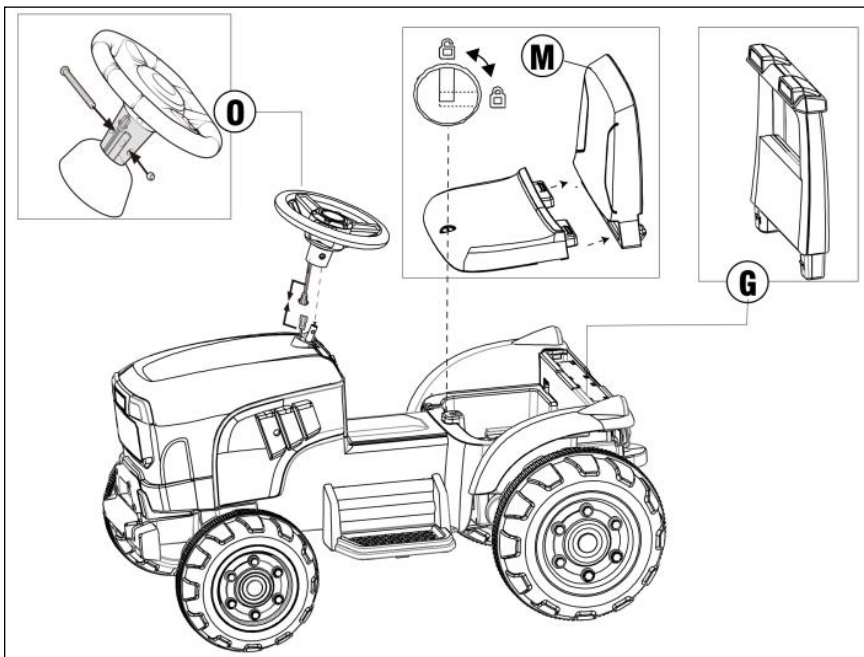

⓪ Fix the steering wheel.

- Remove the nut and bolt from the steering wheel.
- Connect the wires coming from the steering column to the wires on the steering wheel.
- Insert the steering wheel over the steering and secure with nut and bolt.

Ⓜ Fix the seat.

- Merge seat.
- Clip the seat into the body.
- Rotate the latch on the seat to secure the seat

ⓖ Fix the tailstock.

- Clip the tailstock into the body slot.

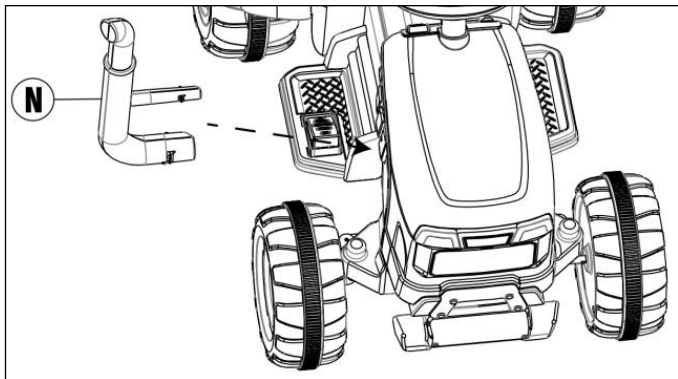

Ⓝ Fix the chimney

- Clip chimney into the body slot.

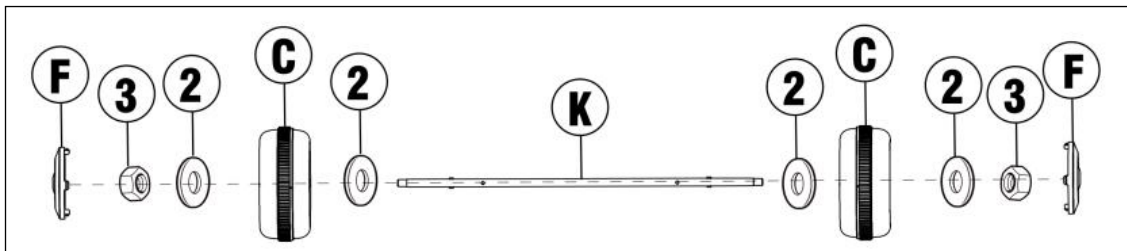

Ⓚ Ⓢ Ⓛ

Fix the rear bucket wheel and rear bucket wheel cover.

- Put the gaskets, bucket wheel, gaskets and nut into the car bucket axle in turn.
- Fix the nut with the M10 wrench and then attach the bucket wheel cover to the bucket wheel.

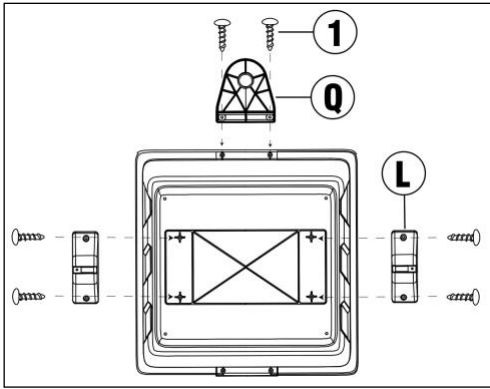

① Fix the car bucket connection.

- Clip the car bucket connection into the car bucket and fix it with M4 * 10mm screw.

② Fix the car bucket axle fixed seat.

- Clip the car bucket axle fixed seat into the car bucket and fix it with M4 * 10mm screw. (Note: pay attention to the direction when installing car bucket axle fixed seat, as shown in the figure)

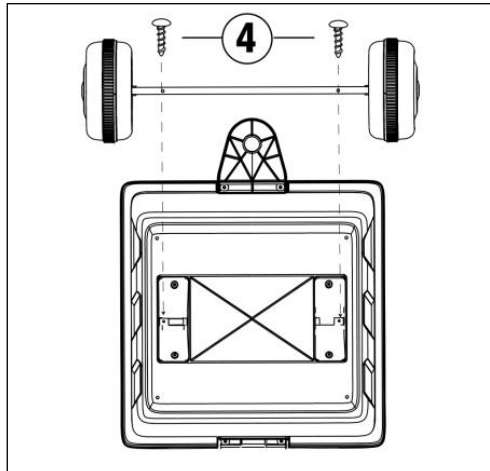

④ Fix the car bucket axle.

- Clip the car bucket axle into the car bucket axle fixed seat and fix it with M4 * 20mm screw.

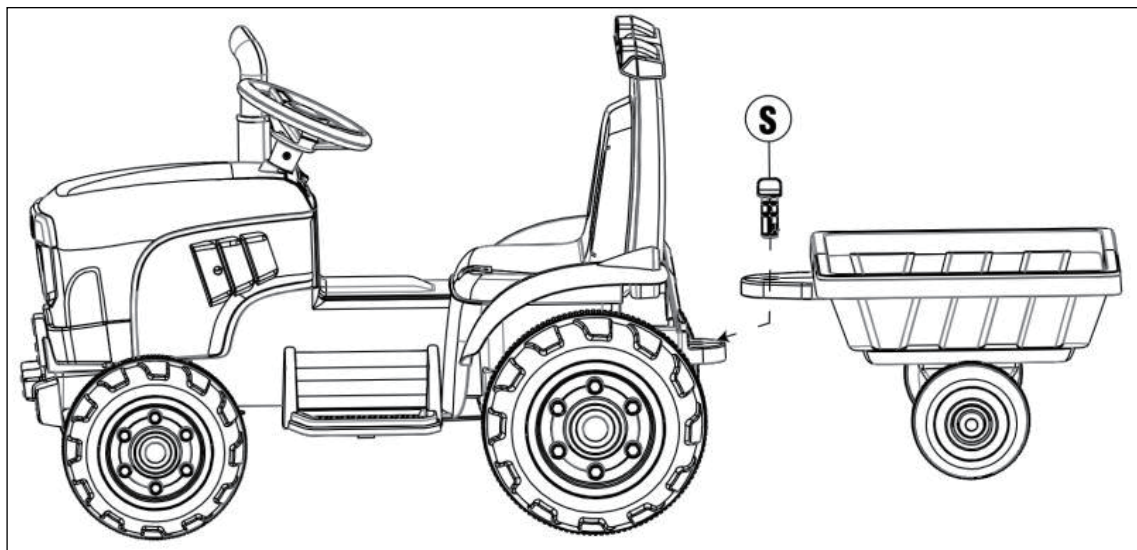

⑤ Fix the car bucket latch.

- Connect the vehicle body with the car bucket, clip it into the car bucket latch, rotate the car bucket latch fix it.

④ DASHBOARD DIAGRAM

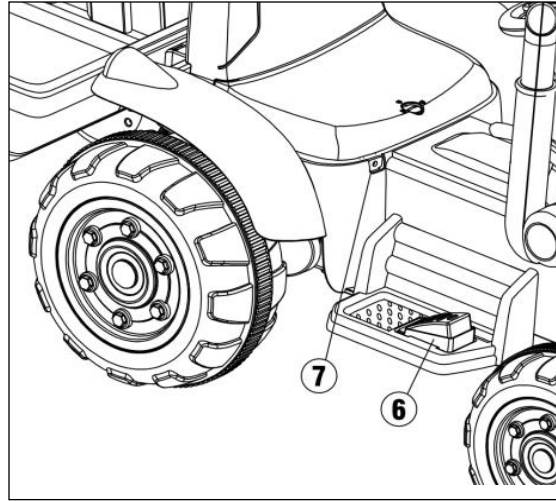
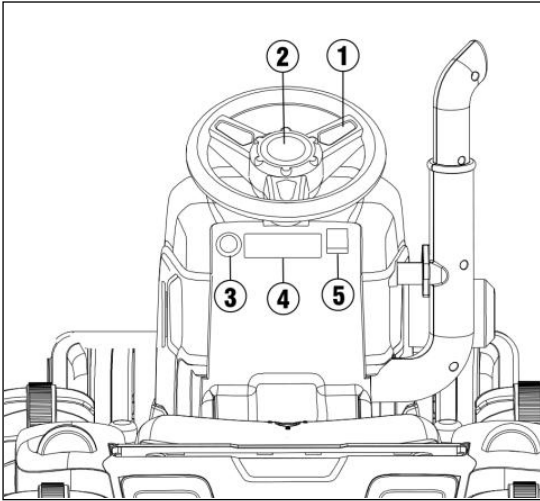

- ① Music Button
- ② Horn button
- ③ Power button
- ④ Control board
- ⑤ Shift Switch: Change the direction of the car. Forward- Backward;
- ⑥ Pedal button: Step on the button, the car will move, when release the car slowly stop;
- ⑦ Socket: Charge.

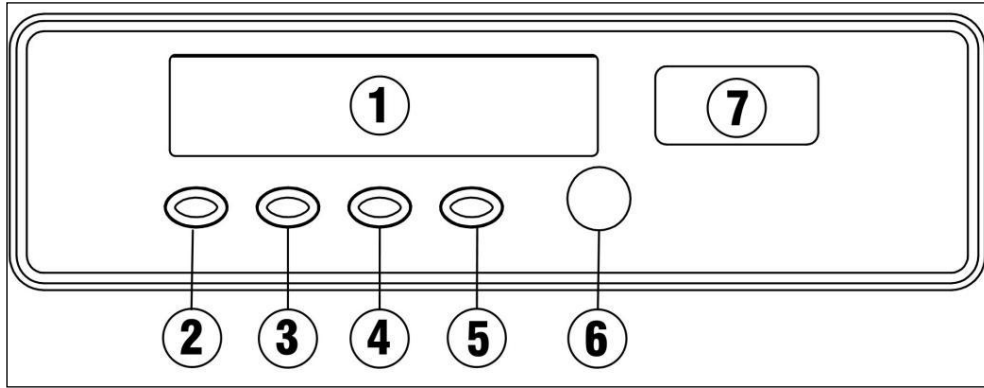

Central control panel:

- ① Power display: Clearly see the battery power, in order to charge; the smaller the number, the lower the voltage. Please charge in time;
- ② Last song/ Volume decrease: Change songs, and long press will decrease volume;
- ③ Play or stop switch;
- ④ Next song/ Volume increase: Change songs, and long press will increase volume;
- ⑤ Mode switch: Press to switch mode/ music mode/ radio mode/ Wireless Technology (Press the button to enter, and you can hear the "Du" sound. Then select the device named "YX" on your mobile phone. The device prompts "connected," which means the pairing is successful. After connected, the car can play music from your mobile phone.);
- ⑥ MP3: The data cable can be connected to other devices and play music;
- ⑦ U: System for connecting external equipment.

⑤ REMOTE CONTROL DIAGRAM

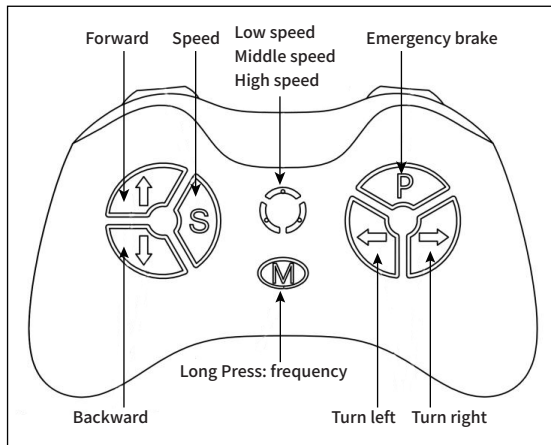

Remote control first. When the remote control is on, foot pedal is not workable.

This product does not provide dry batteries.

Operation Manual:

Take out the remote control, open the battery compartment on the back of the remote control and add two AAA LRO3 alkaline batteries (not included). Pay attention to the polarity of the batteries. When the alignment light and speed indicator light up, it indicates that the battery installed is correct. This product does not provide dry batteries.

<Button Description >

① Long press on the frequency key (M) 2-4 seconds. Low speed LED light flashing. Turn on the power of the car. Low speed LED light keep flashing to long lighting, then frequency bind succeed. If the frequency bind failed (Low speed LED light flashing), remove the battery and repeat steps.

If the frequency bind failed (Low speed LED light flashing), remove the battery and repeat steps

P: Press to brake.

⚠ WARNING!

Only used by adults

S: Speed: press to change speed (low, middle and high speed).

△ Forward ▽ Backward ◁ Turn left ▷ Turn right

② Brake button: Press it to stop moving; press it again to move.

③ Speed selection key and speed indication: used to select speed of the car. Press the key once to switch the speed once. 3 speeds are cyclically switched, and the switching sequence is: low-medium-high. The speed indicator is arranged from top to bottom on the remote control: high-speed lamp, medium-speed lamp, low-speed lamp; when switching to one speed, the corresponding indicator lamp will light up.

Note: The speed grade changes only when moving forward

④ Forward/backward keys: used for forward and backward movement control. When one of the keys is pressed, the moving speed will slowly increase to reach the set speed level. Therefore, children will not have a sudden impact.

⑤ Left turn/right turn key: used for left and right direction control.

Note: without operation after 10 seconds, indication light will off into power saving mode

WARNING

The remote control is not a toy. It is for the adult use only, and should not be used by a child.

A close adult supervision is always required.

Reception range may change significantly with weather, battery, and other environmental conditions.

⑥ CHARGING INSTRUCTIONS

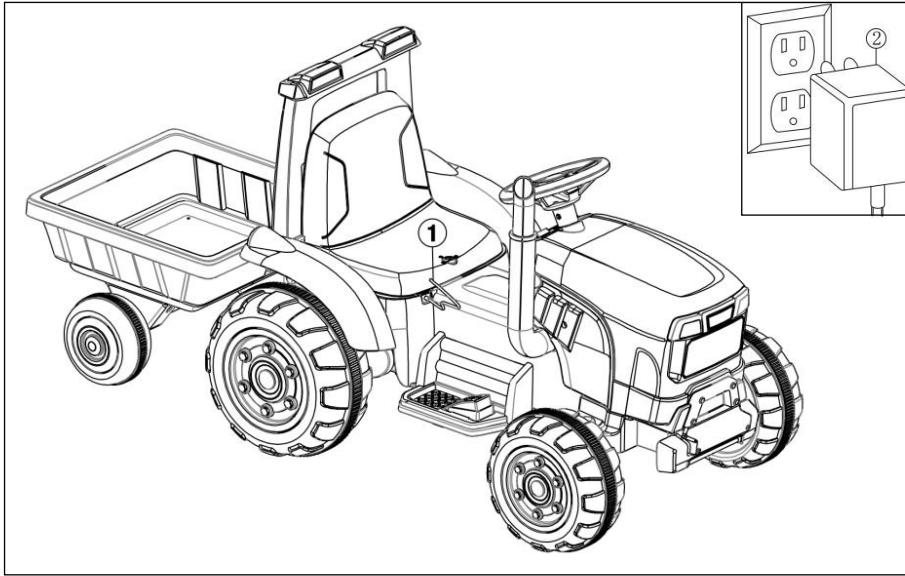

1. Insert the charger jack into the charging hole of the car.

2. Plug the charger plug into the stable matching AC power supply as shown in the picture.

- Charge the battery 4 to 6 hours before initial use.
- On average, you will need to charge the battery between 8 and 12 hours. Do not charge the battery for more than 20 hours. Failure to charge the battery as directed could cause permanent damage to the battery and void the warranty.
- Damage to the battery may occur if it is allowed to drain completely. Do not allow the battery to drain completely.
- Check the battery and charger (supply cord, connector) for wear and damage before charging. Do not charge the battery if damage has occurred.
- Only an adult who has read and understood the safety warnings should handle, charge and recharge the battery.

⑦ MAINTENANCE

The vehicle should be checked for damage, missing or badly worn parts before use.

- Check the tightness of the fasteners before each use.
- Check the tightness of the wheels.
- Ensure the battery is securely in place before use.
- Occasionally use lightweight oil to lubricate moving parts such as wheels and steering linkage.
- Do not use oil on plastic or nylon parts. No lubrication is required.
- Store the vehicle indoors or cover it with a tarp to protect it from the wet weather. Keep it away from sources of heat, such as stoves and heaters.
- Clean the vehicle with a soft, dry cloth. To restore shine to plastic parts, use a non-wax furniture polish. Do not use car wax, abrasive cleaners or wash the vehicle with soap and water. Water will damage the motor, electrical system and battery.
- Joywhale recommend you ask professional advice from our technical team if you need maintenance or repair service. Official email address of Joywhale: **care@joywhale.com**

TROUBLESHOOTING

| Problem | Possible Cause | Remedy |
|--|--------------------------------------|--|
| Vehicle does not run | Battery low on power | Recharge battery (see Battery: Recharge Interval and Time) |
| | Thermal fuse has tripped | Let the vehicle rest for 5 to 10 minutes before continuing normal operation. |
| | Battery connector or wires are loose | Check that the battery connectors are firmly plugged into each other. If wires are loose around the motor, please contact customer service department by email: care@joywhale.com |
| | Battery is dead | Replace battery (Please contact customer service department by email: care@joywhale.com for further help) |
| | Electrical system is damaged | Please contact customer service department by email: care@joywhale.com |
| | Motor is damaged | Please contact customer service department by email: care@joywhale.com |
| Vehicle does not run very long | Battery is under charged | Check that the battery connectors are firmly plugged into each other when recharging |
| Loud grinding or clicking noises coming from motor or gear box | Motor or gears are damaged | Please contact customer service department by email: care@joywhale.com |

| Problem | Possible Cause | Remedy |
|---|---|--|
| Vehicle runs sluggishly or beeping occurs | Battery low on power | Recharge battery |
| | Battery is old | Replace battery (Please contact customer service department by email: care@joywhale.com for further help) |
| | Vehicle is over loaded | Reduce weight on vehicle (see User Requirements and Safety Warnings) |
| | Vehicle is being used in harsh conditions | Operate the vehicle level ground and firm surfaces (see User Requirements and Safety Warnings) |
| Vehicle needs a push to go forward | Poor contact of wires or connectors | Check that battery connectors are firmly plugged into each other. If wires are loose around the motor, please contact customer service department by email: care@joywhale.com |
| | “Dead Spot” on motor | A dead spot means the electric power is not being delivered to the terminal connection and the vehicle needs repair. Please contact customer service department by email: care@joywhale.com |
| 12V Battery will not recharge | Battery connector or adapter connector is loose | Check that battery connectors are firmly plugged into each other |
| | Charger not plugged in | Check that battery charger is plugged into a working wall outlet |
| | Charger is not working (lights not glowing) | Please contact customer service department by email: care@joywhale.com |
| Battery bubbles or gurgles when charging | This is normal and not a cause for concern | |
| Charger feels warm when recharging | This is normal and not a cause for concern | |

CARING FOR YOUR RIDE-ON

- Park the vehicle indoors or cover it with a tarp to protect it from wet weather.
- Do not leave the vehicle in the sun for long periods of time or fading may occur. Store in shade or cover with tarp.
- Do not wash the vehicle with a hose.
- Do not wash the vehicle with soap.
- Charge battery at least once a month to prolong the life of the battery.

CARING FOR YOUR RIDE-ON

If you have any questions about the steps of installing the product or if there are any problems with the product in use, please feel free to contact the customer service of your purchase platform by email.

WARNING

The battery on the vehicle is not replaceable.

- Do not mix old and new batteries.
- Do not mix alkaline, standard(carbon-zinc) or recharge able batteries.
- Non-rechargeable batteries should not be charged.
- Rechargeable batteries should be charged under adult supervision only.
- Exhausted batteries should be removed.
- The supply terminals should not be short-circuited.
- Do not put batteries next to or in a heat source(fire, electronic heating device, etc.).
- Do not hit batteries against hard objects.
- Do not submerge batteries in water.
- Batteries should be inserted with the correct polarity.

IMPORTANT

- Always charge battery for 4-6hrs the first time you use it.
- Always charge battery for 8-12hrs after each use.
- Charge the battery once a month, even if you are not using your vehicle.

WARNING

- Protective equipment should be worn. Not to be used in traffic.
- The toy should be used with caution since skill is required to avoid falls or collisions causing injury to the user or third parties.
- To reduce the risk of injury, adult supervision is required. Never use in roadways, near motor vehicles, on or near steep inclines or steps, swimming pools or other bodies of water; always wear shoes, and never allow more than one rider.

WARNING

CHOKING HAZARD-Small parts.
Not for children under 3yrs.
To reduce the risk of injury, adult supervision is required. Never use in roadways. Never motor vehicles, on or near steep inclines or steps, swimming pools or other bodies of water; always wear shoes, and never allow more than one rider.

WARNING

ADULT ASSEMBLY REQUIRED

WARNING

Not to be used in traffic

CARING FOR YOUR RIDE-ON

Caution:

This device complies with Part 15 of the FCC Rules. Operation is subject to the following two conditions:

① This device may not cause harmful interference.

② This device must accept any interference received, including interference that may cause undesired operation.

Changes or modifications not expressly approved by the party responsible for compliance could void the user's authority to operate the equipment. This equipment has been tested and found to comply with the limits for a Class B digital device, pursuant to part 15 of the FCC Rules. These limits are designed to provide reasonable protection against harmful interference in a residential installation. This equipment generates uses and can radiate radio frequency energy and, if not installed and used in accordance with the instructions, may cause harmful interference to radio communications. However, there is no guarantee that interference will not occur in a particular installation. If this equipment does cause harmful interference to radio or television reception, which can be determined by turning the equipment off and on, the user is encouraged to try to correct the interference by one or more of the following.

Measures:

—Reorient or relocate the receiving antenna.

—Increase the separation between the equipment and receiver.

—Connect the equipment into an outlet on a circuit different from that to which the receiver is connected.

—Consult the dealer or an experienced radio / TV technician for help.